

Pietro Chiesa ■ 1932

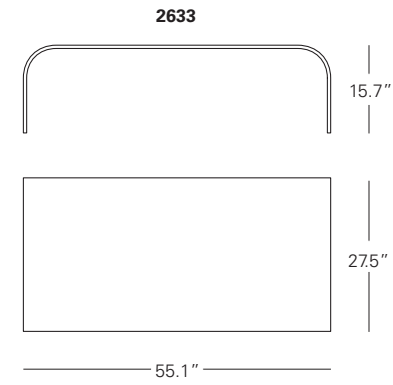
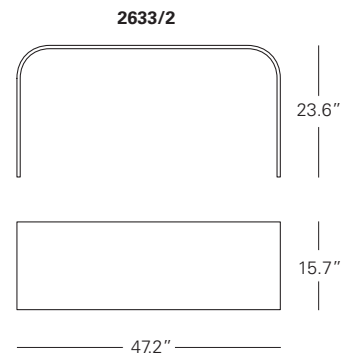
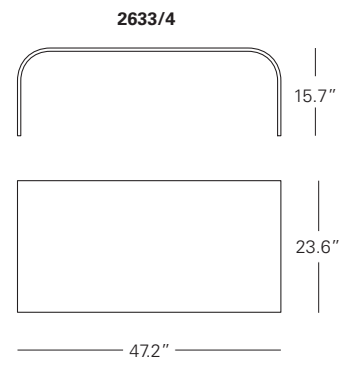
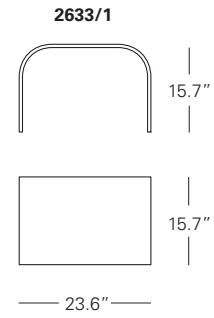

Coffee table. Curved and ground float-glass (0.6").

Product selected by The Museum of Modern Art, New York, USA.

Fontana

Mesita de cristal float (espesor 0.6"), curvado y biselado.

Table basse en verre float (épaisseur 0.6"), courbé et biseauté.

