



MAGNUSSEN<sup>®</sup>  
H O M E

Beyond the expected.<sup>®</sup>

ASSEMBLY INSTRUCTION : MODE D'EMPLOI:INSTRUCCIONES DE ENSAMBLE

T1908-03

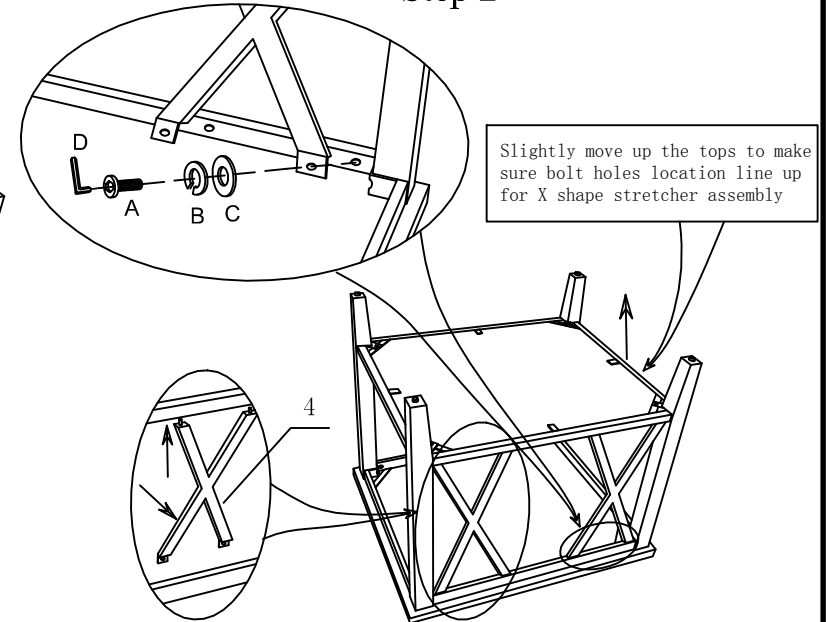
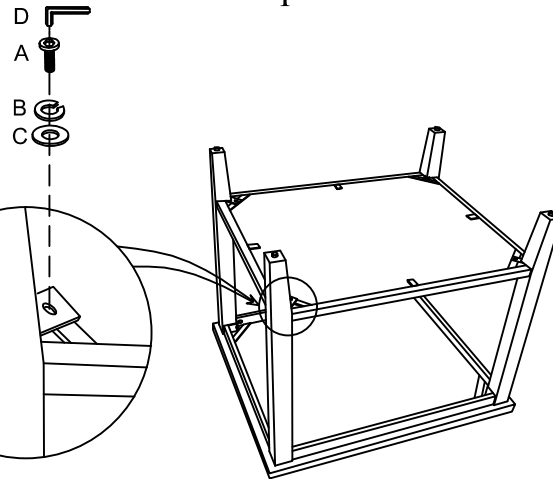
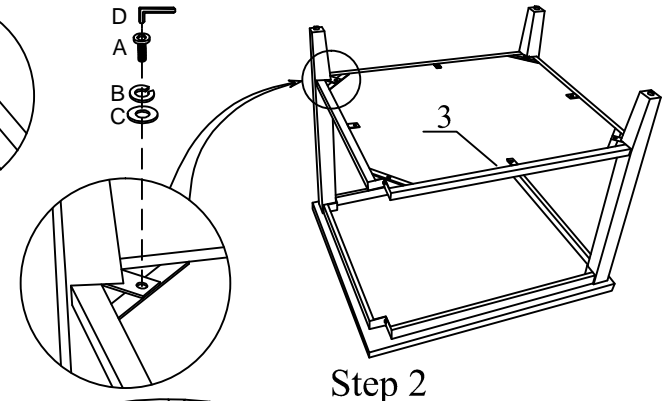
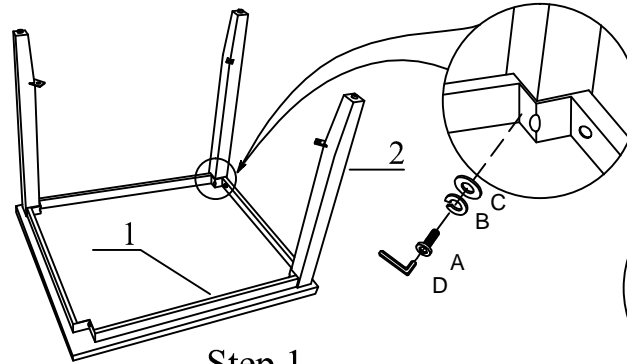
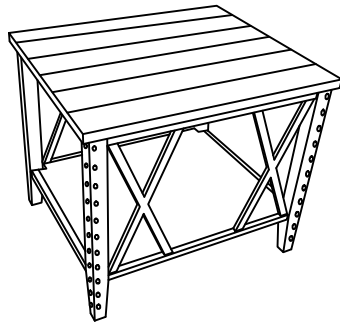

COMPONENTS

No.	PART	MAG. CODE	QTY.	DESCRIPTION
1			1 PC	TOP
2		PT1908-03L	4PCS	LEG
3		PT1908-03S	1 PC	BOTTOM SHELF
4		PT1908-03X	4 PC	X SHAPE STRETCHER

ASSEMBLY HARDWARE

A		1/4" *3/4"L	16PCS	Bolt
B		1/4"	16PCS	Lock Washer
C		1/4"	16PCS	Flat Washer
D		1/4"	1 PC	Allen wrench

NOTE:

ASSEMBLE UNIT ON A SOFT SURFACE.  
ASSEMBLEZ L'UNITÉ SUR UNE SURFACE MOLLE.  
ENSAMBLE LA UNIDAD EN UNA SUPERFICIE PLANA Y SUAVE.

DO NOT TIGHTEN BOLTS UNTIL THE UNIT IS COMPLETELY ASSEMBLED.  
NE SERREZ PAS LES BOULONS JUSQU'À CE QUE L'UNITÉ SOIT COMPLÈTEMENT ASSEMBLÉE.  
NO APIRIETE LOS TORNILLOS HASTA QUE LA UNIDAD ESTE COMPLETAMENTE ENSAMBLADA.



MAGNUSSEN<sup>®</sup>  
H O M E

Beyond the expected.<sup>®</sup>

ASSEMBLY INSTRUCTION : MODE D'EMPLOI:INSTRUCCIONES DE ENSAMBLE

T1908-43

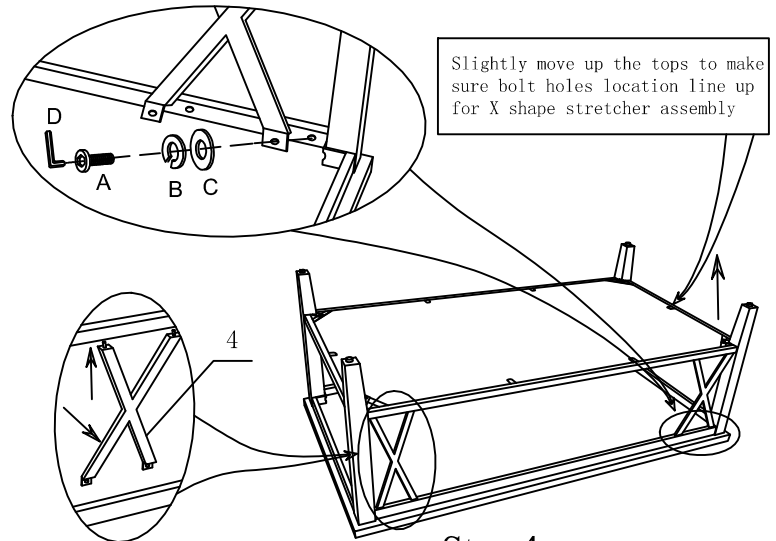
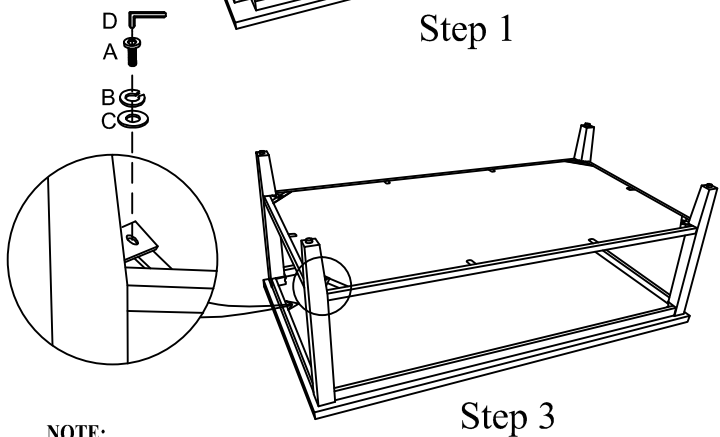
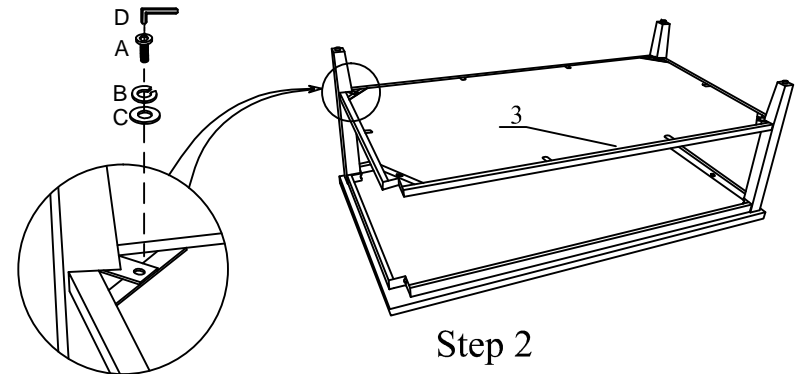
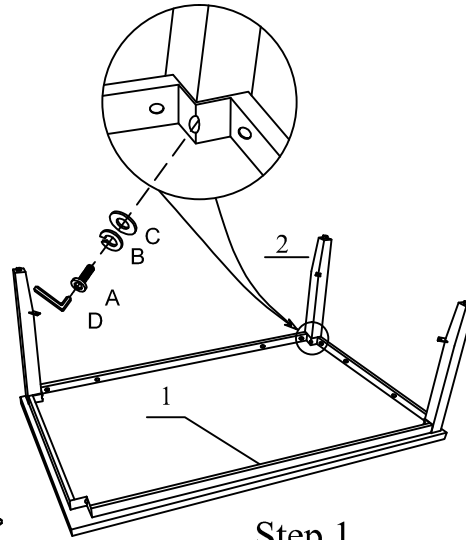
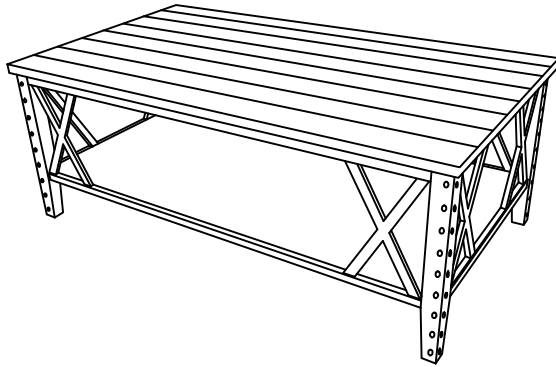

COMPONENTS

No.	PART	MAG. CODE	QTY.	DESCRIPTION
1			1 PC	TOP
2		PT1908-43L	4PCS	LEG
3		PT1908-43S	1 PC	BOTTOM SHELF
4		PT1908-43X	8 PC	X SHAPE STRETCHER

ASSEMBLY HARDWARE

A		1/4" *3/4"L	24PCS	Bolt
B		1/4"	24PCS	Lock Washer
C		1/4"	24PCS	Flat Washer
D		1/4"	1 PC	Allen wrench

NOTE:

ASSEMBLE UNIT ON A SOFT SURFACE.  
 ASSEMBLEZ L'UNITÉ SUR UNE SURFACE MOLLE.  
 ENSAMBLE LA UNIDAD EN UNA SUPERFICIE PLANA Y SUAVE.

DO NOT TIGHTEN BOLTS UNTIL THE UNIT IS COMPLETELY ASSEMBLED.  
 NE SERREZ PAS LES BOULONS JUSQU'À CE QUE L'UNITÉ SOIT COMPLÈTEMENT ASSEMBLÉE.  
 NO APRIETE LOS TORNILLOS HASTA QUE LA UNIDAD ESTE COMPLETAMENTE ENSAMBLADA.



MAGNUSSEN<sup>®</sup>  
H O M E

Beyond the expected.<sup>®</sup>

ASSEMBLY INSTRUCTION : MODE D'EMPLOI:INSTRUCCIONES DE ENSAMBLE

T1908-73

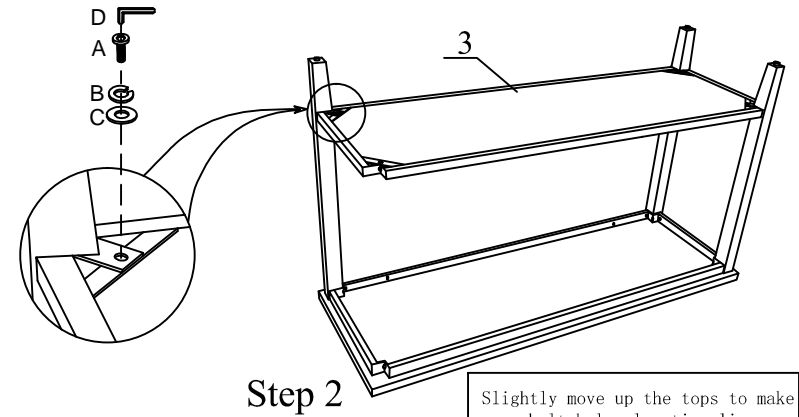
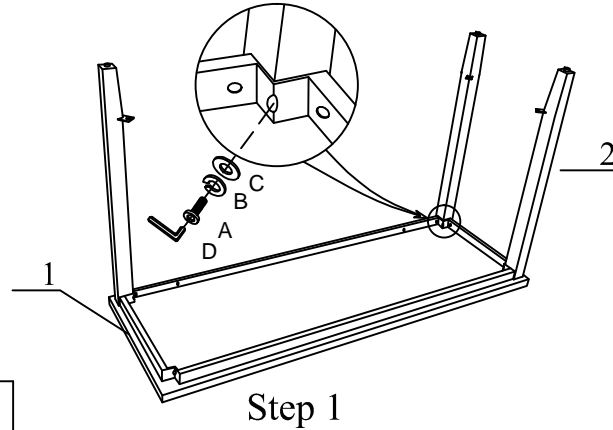
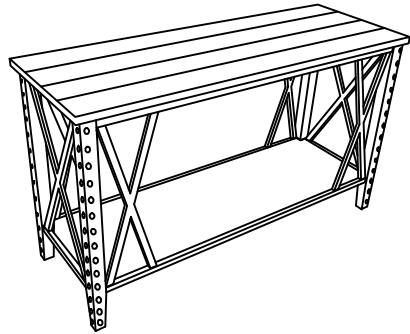

Slightly move up the tops to make sure bolt holes location line up for X shape stretcher assembly

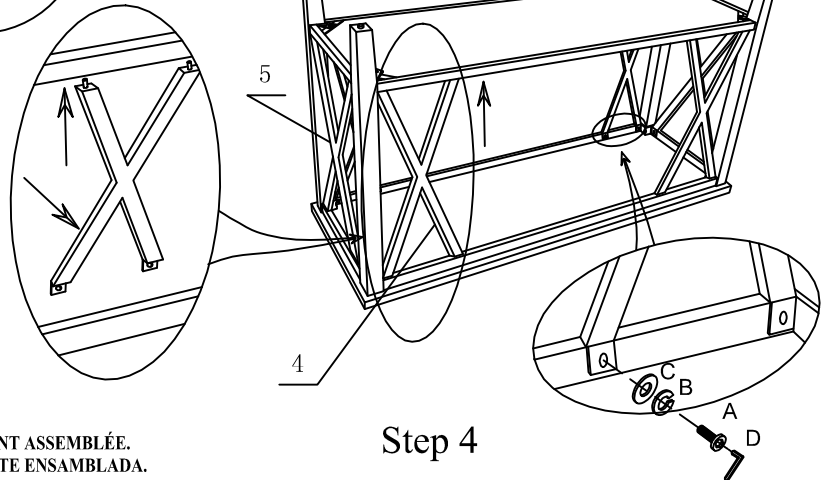
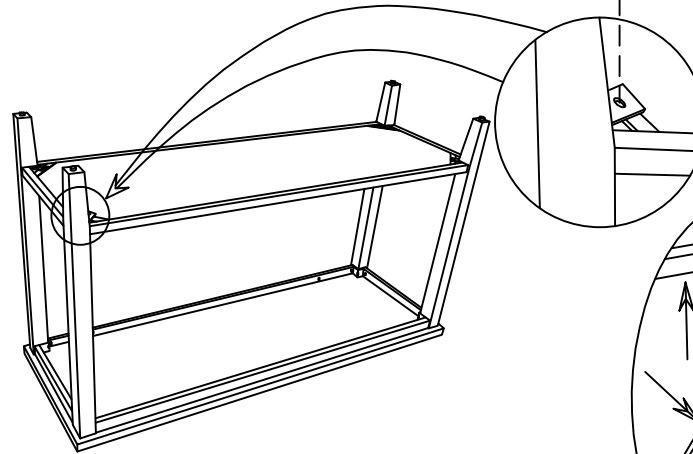

COMPONENTS

No.	PART	MAG. CODE	QTY.	DESCRIPTION
1			1 PC	TOP
2		PT1908-73L	4PCS	LEG
3		PT1908-73S	1 PC	BOTTOM SHELF
4		PT1908-73 X1	4 PC	X SHAPE STRETCHER 2
5		PT1908-73X	2 PC	X SHAPE STRETCHER 1

ASSEMBLY HARDWARE

A		1/4" *3/4"L	20PCS	Bolt
B		1/4"	20PCS	Lock Washer
C		1/4"	20PCS	Flat Washer
D		1/4"	1 PC	Allen wrench

NOTE:

ASSEMBLE UNIT ON A SOFT SURFACE.  
 ASSEMBLEZ L'UNITÉ SUR UNE SURFACE MOLLE.  
 ENSAMBLE LA UNIDAD EN UNA SUPERFICIE PLANA Y SUAVE.

DO NOT TIGHTEN BOLTS UNTIL THE UNIT IS COMPLETELY ASSEMBLED.  
 NE SERREZ PAS LES BOULONS JUSQU'À CE QUE L'UNITÉ SOIT COMPLÈTEMENT ASSEMBLÉE.  
 NO APRIETE LOS TORNILLOS HASTA QUE LA UNIDAD ESTE COMPLETAMENTE ENSAMBLADA.