

16597



Call Us First!
DO NOT RETURN TO STORE.

For immediate help with assembly or product information
call our toll-free number:

1-888-827-9056

or email:

customerservice@backyardproductsllc.com

Our staff is ready to provide assistance.

April through October M - F 8:00 AM to 7:00 PM EST

Saturday 8:30 AM to 4:30 PM EST

November through March M - F 8:00 AM to 5:00 PM EST

(This page intentionally left blank.)

Solar Shed



Patent No. 5,937,591

10'x8', 10'x12', 10'x16' Building Instructions

-BEFORE YOU BEGIN-

■ First...

Read these instructions thoroughly before you begin assembly. Assembly is easiest if you follow the steps in the order shown.

In a drawing, a dotted line represents a part hidden from view (like a part under a panel).

Lumber is graded from only one side. Check the part for the most attractive face and make sure to face it to the outside.

■ Check all parts

Compare parts you have to the list(s) on page 5. If a part is missing, circle the part in question in the parts list and call us toll-free at 1-800-437-0784.

■ Assistance required

We recommend that you assemble this building on level ground in the location it will be used. Assistance is necessary to handle, fit, and secure some components. Two people are needed for some steps.

■ Squareness is very Important!

Keeping all 90° corners and 90° perpendiculars square throughout the assembly of this building will make each succeeding step easier and is necessary to assure that all components fit together properly.

■ Check local zoning

Before starting construction, check with your local building code official for any required permits, variances, etc. Our Storage buildings are designed to meet most national coding agencies strict testing requirements for storage space and are not meant to be used for living space.

■ Check foundation size

Before starting construction on your foundation, check in the instruction manual to ensure that you are building the correct size foundation for your building.

Always wear OSHA-APPROVED safety glasses throughout assembly process

■ Tools required

- Hammer
- Phillips Screwdriver
- Level
- Step Ladder
- Pencil
- Tape Measure
- Adjustable Wrench
- Electric Drill with 1/2" Drill Bits and #2 Phillips bit
- 1/8" Allen Wrench

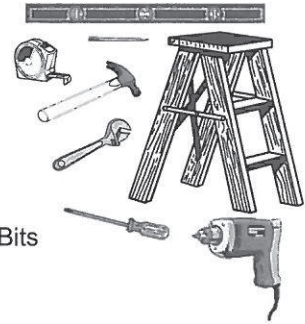

■ Optional tools

- Chalk Line
- Square
- Nail Pouch
- Wood Glue

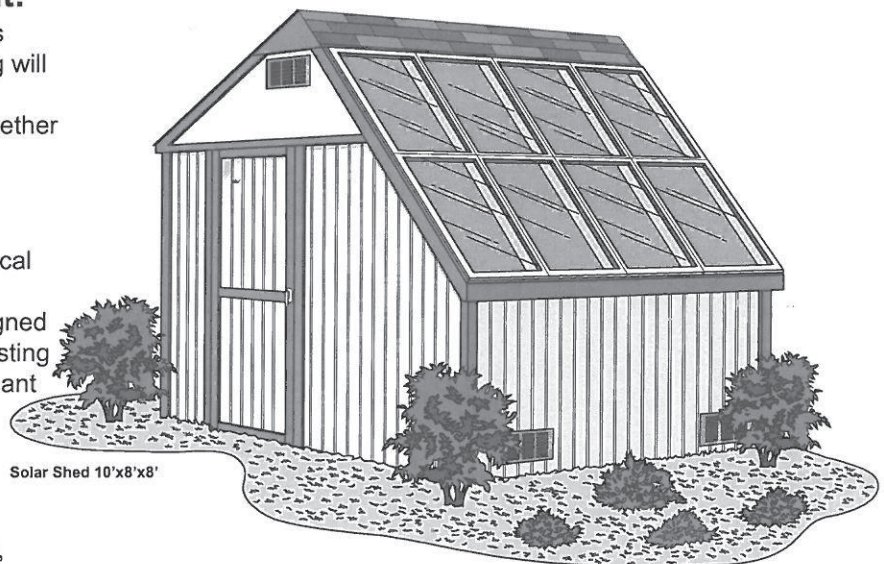
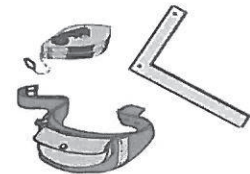

Solar Shed 10'x8'x8'

Building Layout

Your Solar Shed can be configured in a variety of ways. Available extender kits can increase the size of your building from 10' x 8' to 10' x 12' or 10' x 16'. Also, for added flexibility, the doors can be located on the side or tall wall.

This booklet contains instructions for these different configurations. To aid you in constructing your building, the layout plans below show the available Solar Shed configurations. Locate the view that best matches the building and options you have purchased along with the configuration that best suits your needs. Then, use the accompanying index to identify and locate the assembly procedures for your building.

Building Size
10 x 8

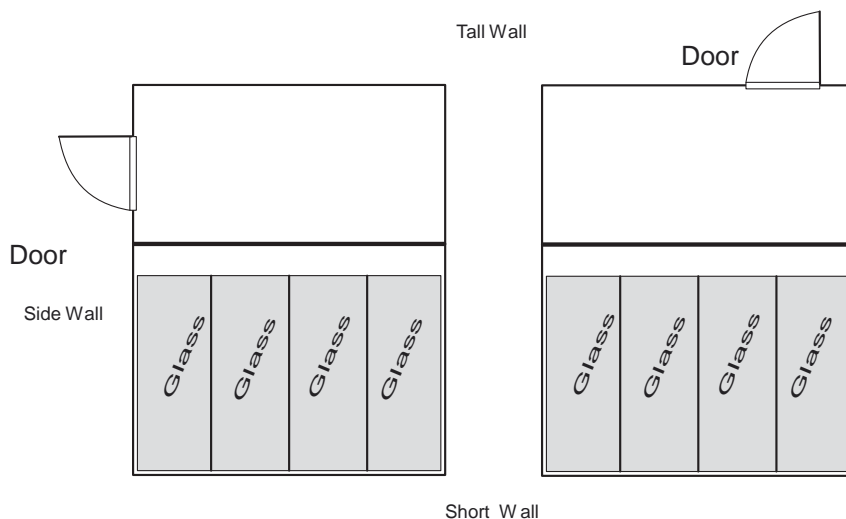

Door Side Wall	Page #	Door Tall Wall	Page #
Floor	6-8		6-8
Side Wall	10-12		10-12
Side Wall w Door	13-15		N/A
Short Wall	16-17		16-17
Tall Wall	23-25		26-28
Erecting Walls	41-42		41-42
Assemble Trusses	43-44		43-44
Erect Trusses	45-46		45-46
Gable Ends	48		48
Installing Roof Panels	49		49
Installing Gable Trim	52		52
Installing Trim	53-54		53-54
Installing Door	55-58		55-58
Installing Windows	59-60		59-60
Installing Vents	61		61

*** OPTIONAL
SIDE WALL
WINDOW NOT
SUPPLIED WITH
THE KIT. SEE
PAGE 62 FOR
INSTALLATION
INSTRUCTIONS.**

Extender kits can be solid roof or glass window.

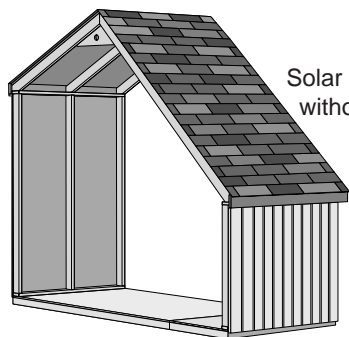

Solar Shed Extender
without windows

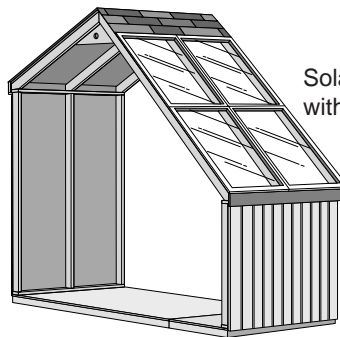

Solar Shed Extender
with windows

Building Size
10 x 12

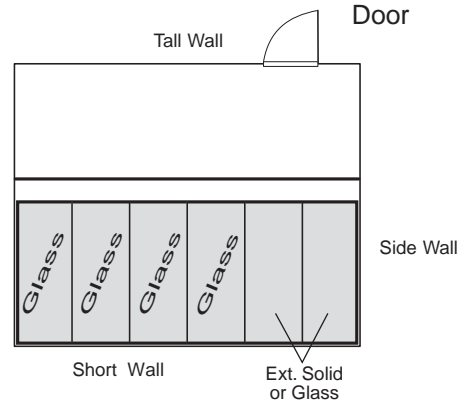
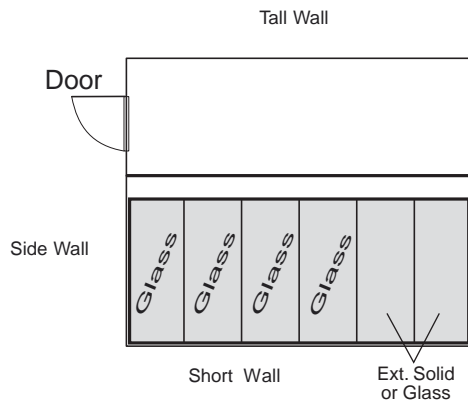

Door Side Wall	Page #	Door Tall Wall	Page #
Floor	6-9		6-9
Side Wall	10-12		10-12
Side Wall w Door	13-15		N/A
Short Wall	18-19		18-19
Tall Wall	29-31		35-37
Erecting Walls	41-42		41-42
Assemble Trusses	43-44		43-44
Erect Trusses	45-47		45-47
Gable Ends	48		48
Installing Roof Panels	50		50
Installing Gable Trim	52		52
Installing Trim	53-54		53-54
Installing Door	55-58		55-58
Installing Windows	59-60		59-60
Installing Vents	61		61

Building Size
10 x 16

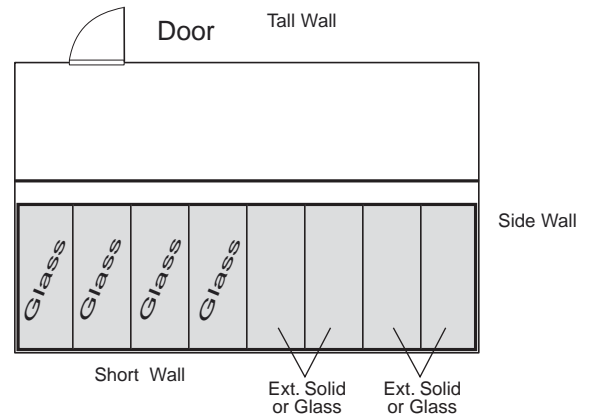
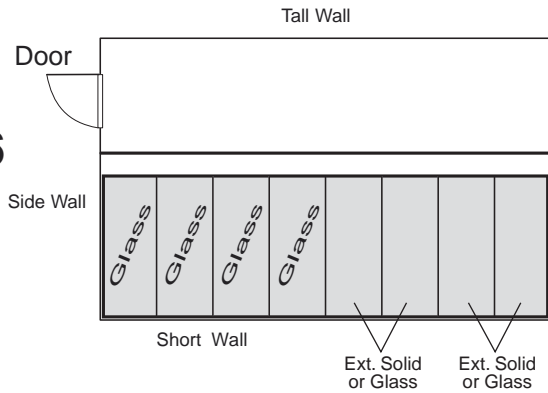

Door Side Wall	Page #	Door Tall Wall	Page #
Floor	6-9		6-9
Side Wall	10-12		10-12
Side Wall w Door	13-15		N/A
Short Wall	20-22		20-22
Tall Wall	32-34		38-40
Erecting Walls	41-42		41-42
Assemble Trusses	43-44		43-44
Erect Trusses	45-47		45-47
Gable Ends	48		48
Installing Roof Panels	51		51
Installing Gable Trim	52		52
Installing Trim	53-54		53-54
Installing Door	55-58		55-58
Installing Windows	59-60		59-60
Installing Vents	61		61

Solar Shed Helpful Hints!

■ The Location

Positioning of the Solar Shed in relation to your house or garden is an important consideration and unless your house or Solar already faces South you may be missing out on the solar benefits of the sun.

To take advantage of solar gain, orient the Solar Shed so that the roof windows are facing southward. If you intend to use the Solar Shed for starting plants or growing into the late fall, it would be best to have it facing 15° East or West of true South.

■ More Location Hints

- Check the site, to make sure it receives the most sunlight possible during daylight hours.
- If your planing to use your Solar Shed as an office or workshop you may choose to face it away from the sun this will make things easier when trying to cool your Solar Shed in summer.
- Your Solar Shed must be constructed on a level floor. Preparing the site will be considerably easier if you begin with fairly level ground.
- Your building location must be on firm soil and must be free from any puddling or drainage problems

■ Leveling and Squaring

While constructing your Solar Shed, stop periodically to check that the building is level and square. Advancing from one step to the next without checking for squareness may result in increased difficulty with subsequent steps.

■ Painting and Weather Proofing

Your Solar Shed must be painted with a latex exterior paint within thirty days of assembly. If you intend to use the Solar Shed as a greenhouse, you must prime and paint the inside of the building as well as the wooden floor (provided your building has a wooden floor). Caulking is also a must and should be applied above door and all horizontal and vertical trim boards. Refer to your warranty for more detailed information on weatherproofing.

■ Important Notice

We pride ourselves in manufacturing kits from select construction grade lumber and engineered wood products. Construction grade lumber, a product cut from trees, has many natural characteristics and blemishes that may be present in some of the pieces you receive in your kit. Natural characteristics and blemishes in construction lumber may include knots, torn wood grain along edges, minor cracks/splits, twists, limited bark along edges and pitch pockets that may exude sap. Be assured that the individual parts have been cut and inspected to remove as many of the wood's natural, less appealing characteristics as possible. These characteristics and/or blemishes will not affect the strength, durability, or structural integrity of the finished product. Generally, the exterior trim parts selected for your kit are graded from only one side and should be installed with the most attractive side outward. Our limited warranty does not cover the natural characteristics and blemishes that occur with construction grade lumber products.

NATIONAL STANDARD LUMBER SIZES

Nominal size	Actual size
1 x 2 =	3/4" x 1-1/2"
1 x 3 =	3/4" x 2-1/2"
1 x 4 =	3/4" x 3-1/2"
2 x 4 =	1-1/2" x 3-1/2"
2 x 6 =	1-1/2" x 5-1/2"

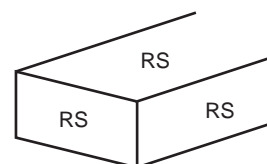

Part Letters are located ends or sides.

IMPORTANT!!!

Building Tip

FOR THE BEST LOOKING FINISHED PRODUCT WE RECOMMEND THAT YOU INSPECT, SORT AND LAY OUT MATERIALS PRIOR TO BEGINNING ASSEMBLY OF YOUR BUILDING

IMPORTANTE!!!

Consejo

CON EL FIN DE OBTENER EL PRODUCTO ACABADO DE MEJOR ASPECTO RECOMENDAMOS QUE INSPECCIONE, CLASIFIQUE Y ORGANICE LOS MATERIALES ANTES DE EMPEZAR A MONTAR SU EDIFICIO

HELPFUL MATERIAL NOTICE

AVISO ÚTIL SOBRE LOS MATERIALES

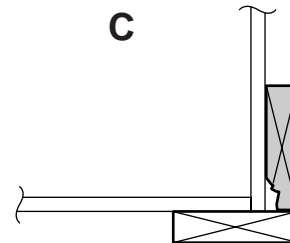
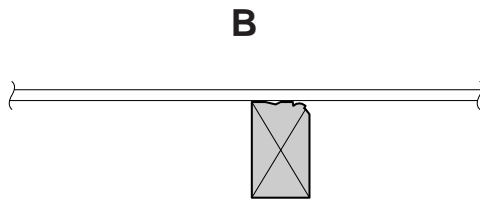
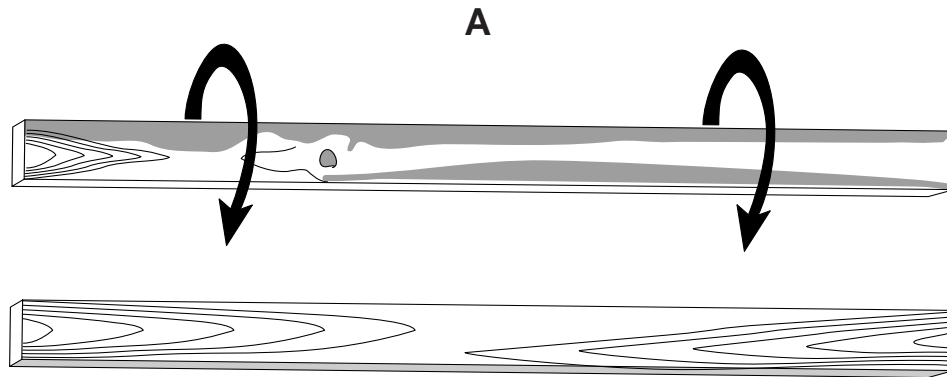

Wood is a natural product that has inherent blemishes. All interior framing is graded for structural strength and not appearance. Exterior trim is graded for one good side per industry standards.

- Blemishes can be easily installed to provide the best appearance. (Fig. A)
- Install wall framing with any blemished sides toward the siding and facing rear of building. (Fig. B)
- Install corner trim, gable trim and fascia with any blemished sides toward the siding material. (Fig. C)

Always install the material leaving the best edge and best surface visible.

Please remember that these blemishes in no way negatively affect the strength or integrity of our product.

La madera es un producto natural que tiene defectos inherentes. Todo la estructura interior ha sido aprobada por ofrecer una resistencia estructural y no por su aspecto. La guarnición exterior ha sido aprobada por tener un buen lado según las normas de la industria.

- La parte con defectos puede instalarse fácilmente de modo que el edificio tenga el mejor aspecto. (Fig. A)
- Instale el entramado de la pared con los lados con defectos apuntando hacia los costados y haciendo frente a la parte trasera del edificio. (Fig. B)
- Instale la guarnición de las esquinas, la guarnición de los hastiales y las impostas con los lados con defectos apuntando hacia el material lateral. (Fig. C)

Instale siempre el material dejando visibles el mejor borde y la mejor superficie.

Recuerde que estos defectos no afectan de forma negativa la resistencia o la integridad de nuestros productos.

Please feel free to call our Consumer Help Line - Toll Free

1-800-437-0784

Monday through Friday

8:00 AM to 5:00 PM EST

Saturday (March through October)

10:00 AM to 4:00 PM EST

Llame de forma gratuita a nuestra línea de ayuda al consumidor

1-800-437-0784

Lunes a viernes

8:00 AM a 5:00 PM, hora estándar del este

Sábado (marzo a octubre)

10:00 AM a 4:00 PM, hora estándar del este

PARTS LIST

Solar Shed 10'x 8', 10'x12', 10'x16'

Complete Parts List for 10' x 8' Building

Qty.	I.D.*	Description	Standard	Metric
2 x 6's				
□ 2	VO		2 x 6 x 92 ⁵ / ₈ "	5 x 14 x 235cm
2 x 4's				
□ 13	TH		2 x 4 x 69 ¹ / ₂ "	5 x 10 x 176.5cm
□ 2	UL		2 x 4 x 92 ⁵ / ₈ "	5 x 10 x 235cm
□ 2	TN	<i>Angled</i>	2 x 4 x 79 ¹ / ₄ "	5 x 10 x 201cm
□ 4	TG		2 x 4 x 56 ¹ / ₂ "	5 x 10 x 143cm
□ 2	SN		2 x 4 x 43 ³ / ₄ "	5 x 10 x 111cm
□ 9	SD		2 x 4 x 33"	5 x 10 x 84cm
□ 1	SC		2 x 4 x 32"	5 x 10 x 81.3cm
1 x 4's				
□ 1	KI		1 x 4 x 93 ³ / ₈ "	5 x 10 x 237cm
□ 2	JB	<i>Angled</i>	1 x 4 x 42 ⁵ / ₈ "	5 x 10 x 130cm
□ 2	KN	<i>Angled</i>	1 x 4 x 87 ⁷ / ₈ "	5 x 10 x 223cm
□ 8	IE		1 x 4 x 21 ¹ / ₄ "	5 x 10 x 54cm
□ 1	KT	<i>Angled</i>	1 x 4 x 93 ³ / ₈ "	5 x 10 x 237cm
1 x 3's				
□ 2	HN		1 x 3 x 79 ⁵ / ₁₆ "	2 x 4 x 220cm
□ 2	CK	<i>Angled</i>	1 x 3 x 38 ¹ / ₂ "	2 x 4 x 98cm
□ 2	ZO		5/8 x 3 x 72"	2 x 4 x 183cm
□ 2	GT		1 x 3 x 71 ¹ / ₂ "	2 x 4 x 182cm
□ 2	DH	Door Stile	5/8 x 3 x 30 ⁵ / ₈ "	2 x 4 x 77.8cm
1 x 2's				
□ 2	CS		1 x 2 x 72"	2 x 4 x 183cm
□ 2	CF		1 x 2 x 35 ¹ / ₄ "	2 x 4 x 89cm
□ 1	CG		1 x 2 x 91 ¹ / ₈ "	2 x 4 x 231cm
□ 4	BU		1 x 2 x 21 ¹ / ₄ "	2 x 4 x 54cm
Rafters				
□ 5	TF	Rafter (Short)	2 x 4 x 64 ⁷ / ₈ "	5 x 10 x 165cm
□ 5	RO	Rafter (Long)	2 x 4 x 93 ¹³ / ₁₆ "	5 x 10 x 238cm
□ 8	--	Wood Gusset	9" x 24"	23 x 61cm
Wall Panels				
□ 2	¹ / ₄ _{IR}	Gable Panel	23 ⁵ / ₈ " x 87 ¹ / ₄ "	61 X 121cm
□ 2	--	Wall Panel	48" x 72"	122 X 183cm
□ 1	--	Wall Panel	44 ³ / ₈ " x 72"	113 X 183cm
□ 2	--	Narrow Wall Panel	23 ⁷ / ₈ " x 72"	6 X 183cm
□ 1	--	Wall Panel	14 ³ / ₈ " x 72"	36 X 183cm
□ 1	--	Wall Panel	35 ¹ / ₄ " x 48"	89 X 122cm
□ 1	--	Short Wall Panel	35 ¹ / ₄ " x 44 ³ / ₈ "	89 X 113cm
□ 2	¹ / ₄ _{IR}	Angled wall Panel	48" x 72"	122 X 183cm
Roof Panels				
□ 1	--	Roof Panel	23 ⁵ / ₈ " x 92 ¹ / ₄ "	60 X 234cm
□ 1	--	Roof Panel	15 ⁷ / ₈ " x 92 ¹ / ₄ "	40 X 234cm
□ 1	--	Roof panel	48" x 92 ¹ / ₄ "	122 X 234cm

* Part Identification letters appear on dimensional lumber and are read Horizontally i.e. (left to right)

Package Material

Several extra wood parts are included in your kit, which are only used for the safe packaging and shipping of the Solar Shed Windows.

Qty.	I.D.*	Description	Standard	Metric
Misc. Parts				
□ 2	--	Gable Spacer	8 ³ / ₄ " x 25 ⁷ / ₈ "	22 x 65cm
□ 4	--	Inside Vent Spacer	9 ¹ / ₈ " x 15 ¹ / ₈ "	23 x 38cm
□ 2	--	Plywood Gable Cap	9 ⁷ / ₈ " x 29 ⁵ / ₁₆ "	24 x 74cm
□ 1	--	Preassembled Door		
□ 1	--	Door Stop	1/2" x 3/4" x 68"	1.3x1.9x172cm
□ 4	--	Adjustable Vents		
□ 4	--	Exterior Vents		
□ 2	--	Soffit End Caps	3/4" x 7 ⁷ / ₈ " x 7 ¹ / ₂ "	1.9x20x19cm
□ 2	--	Door Stiffener	5/8" x 3 ¹ / ₂ " x 61 ¹ / ₄ "	1.6x8.9x155cm
□ 2	--	Door Stiffener	5/8" x 3 ¹ / ₂ " x 31 ¹ / ₄ "	1.6x8.9x79cm

Windows

□ 4	--	Glass Windows		
□ 3	--	Aluminum Mullion Strip (Narrow)		
□ 2	--	Aluminum Mullion Strip (Wide)		
□ 2	Rolls	Foam Weather Strip		

Hardware Kit

□ 2"	(5cm)	Nails, 3"	(7.6cm)	Nails, 3"	(7.6cm)	Screws, 1-1/4"	(3.2cm)	Screws & White Screws, 1"	(2.5cm)	Screws, 3/4"	Screws, 1-1/2"	Finish Nails
□ 1		Door Hardware Kit										
□ 1		Continuous Hinge										

Complete Parts List for 1 Solid Roof Extender or 1 Glass Extender

2 x 6's				
□ 2	VD		2 x 6 x 45 ¹ / ₂ "	5x 14 x 115.5cm
2 x 4's				
□ 3	TH		2 x 4 x 69 ¹ / ₂ "	5 x 10 x 176.5cm
□ 2	SR		2 x 4 x 45 ¹ / ₂ "	5 x 10 x 115.5cm
□ 3	SD		2 x 4 x 33"	5 x 10 x 84cm
1 x 4's				
□ 1	IJ		1 x 4 x 45 ¹ / ₂ "	2 x 10 x 115.5cm
□ 4	IE		1 x 4 x 21 ¹ / ₄ "	2 x 10 x 54cm
□ 1	HZ	<i>Angled</i>	1 x 4 x 45 ¹ / ₂ "	2 x 10 x 115.5cm
1 x 2's				
□ 1	CN		1 x 2 x 46 ¹ / ₄ "	2 x 5 x 115.2cm
□ 2	BU		1 x 2 x 21 ¹ / ₄ "	2 x 4 x 54cm
Rafters				
□ 2	TF	Rafter (Short)	2 x 4 x 64 ⁷ / ₈ "	5 x 9 x 115.3cm
□ 2	RO	Rafter (Long)	2 x 4 x 93 ¹³ / ₁₆ "	5 x 9 x 233.4cm
□ 4	--	Gusset	9" x 24"	28 x 61cm
Wall Panels				
□ 1	--	Wall Panel	45 ¹ / ₂ " x 72"	116.2 X 183cm
□ 1	--	Wall Panel	45 ¹ / ₂ " x 35 ¹ / ₄ "	116.2 X 89.5cm

Roof Panels

□ 1	--	Roof Panel	48" x 45 ¹³ / ₁₆ "	122 X 116.4cm		
□ 1	--	Roof Panel	23 ⁵ / ₈ " x 45 ¹³ / ₁₆ "	61 X 116.4cm		
□ 1	--	Roof Panel	72 x 45 ¹³ / ₁₆ "	183 X 116.4cm (SOLID ROOF ONLY)		
□ 1	--	Roof Panel	15 ⁷ / ₈ " x 45 ¹³ / ₁₆ "	40.3 X 116.4cm		
□ 2	--	Glass Windows (GLASS ROOF ONLY)				
□ 2	--	Aluminum Mullion Strip (Narrow) (GLASS ROOF ONLY)				
□ 1		Roll Foam Weather Strip (GLASS ROOF ONLY)				
□ 1	--	Hardware- 2"	(5cm) Nails, 3"	(7.6cm) Nails; 3"	(7.6cm) Screws, 1-1/4"	Screws & White Screws (GLASS ROOF ONLY)

SITE PREPARATION

SITE PREPARATION

- Site must be properly leveled.
- Site should have natural drainage to eliminate puddling under and around the building.
- Site should be covered with plastic film to discourage grass growth under the building and to serve as a vapor barrier.

Before assembling your building, you must first construct a floor system. You can:

- Purchase our optional pre-cut Floor Kit.
- Purchase materials to cut and build your own wooden floor from the parts list on Page 7 and Page 9 for extender building.

NOTE: Our Pre-cut Floor Kits have been designed for normal residential use. It is characteristic for the floor panels to deflect (flex) during normal use. If you intend to store very heavy objects in your building, you may want to consider adding floor joists to reduce the span from 24" on center to 16" or 12" on center.

OR

- Install a 4" concrete slab floor system.

IF USING CONCRETE SLAB FLOOR SYSTEM

- Construct 4" Concrete Slab Floor System as shown.
- Bolt or nail 2 x 4 treated sill plates to the slab to support the building's frames and wall panels. (Treated sill plates not included.)
- Upon completion of above steps, skip "Floor Kit Assembly" section and proceed to Step #2: Assembling Rear Wall.

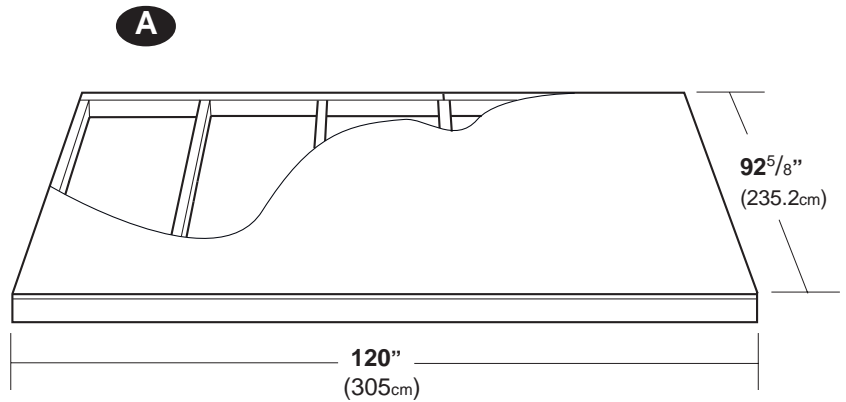

Wooden Floor Kit

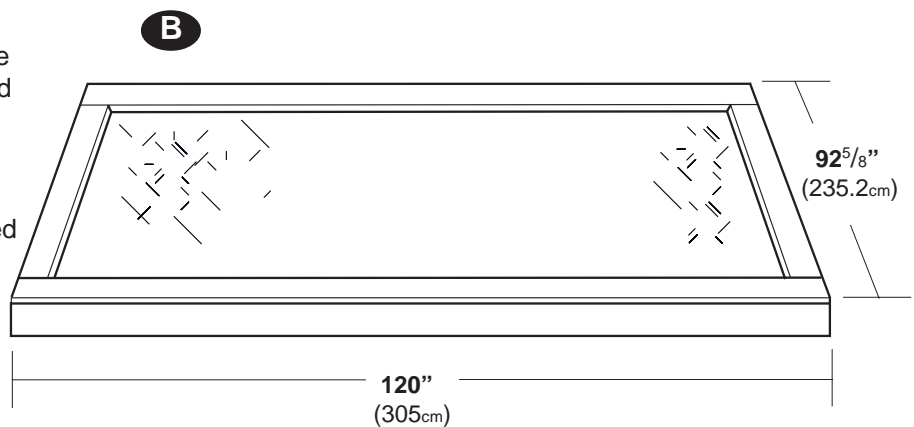

Concrete Slab Floor System

Slab Floor size for Extended Buildings		
120 x 92 ⁵ / ₈ "	10 x 8	305x235.2cm
120 x 138 ¹ / ₈ "	10 x 12	305x365.7cm
120 x 183 ⁵ / ₈ "	10 x 16	305x487.6cm

Phoenix 10 x 8 Floor Kit Instructions

Optional Floor Kit not supplied with Building Kit

For Handy Home optional Wood Floor Kit, refer to instructions included with floor. Floor Instructions maybe different from this manual.

Parts Needed:

- A** 2 - 48x92-5/8x5/8" Floor Panels
- B** 1 - 23-7/8x92-5/8x5/8" Floor Panel
- C** 6 - 2x4x89-1/2" Floor Joist
- D** 2 - 2x4x72" Bond Boards
- E** 2 - 2x4x48" Bond Boards
- 2" and 3" Nails

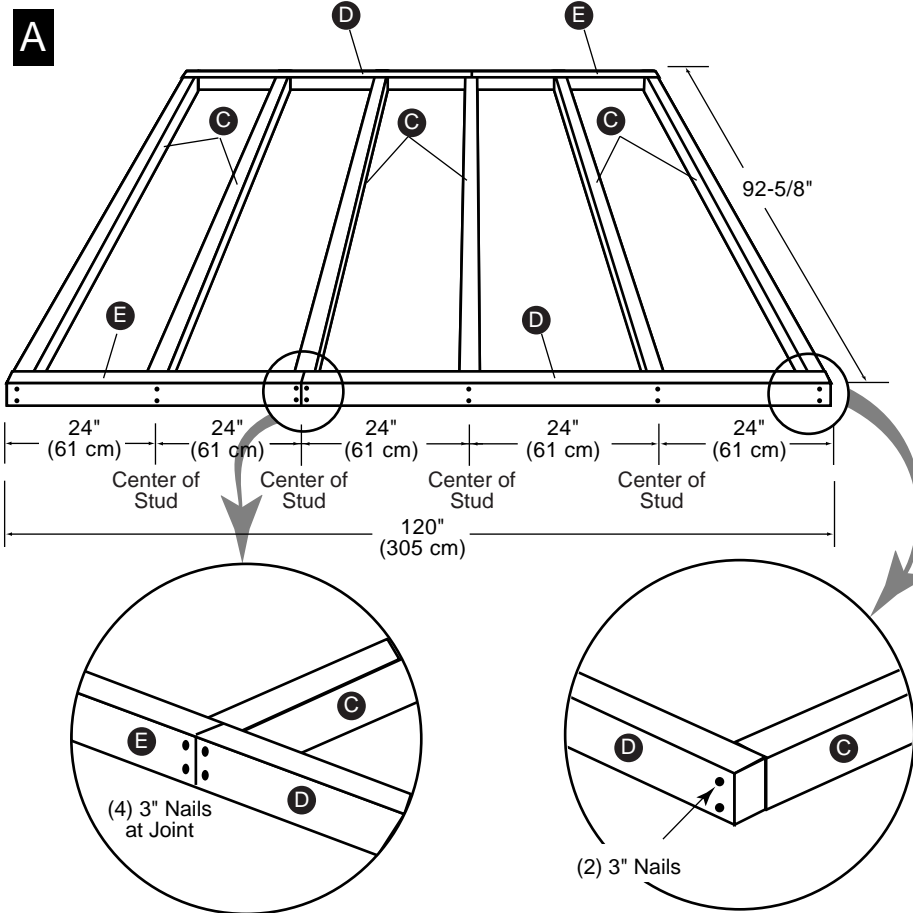

NOTE: Part letters are not stamped on floor kits.

ASSEMBLY OF 10' X 92-5/8" FLOOR FRAME

A: Position Floor Joists **C** 89-1/2", Floor Bond Boards **D** 72", and Floor Bond Boards **E** 48" as shown.

Using 3" nails, nail twice through each Bond Board **D** & **E** into each end of each Joist **C**, keeping pieces flush at top and ends, and maintain 24" spacing. Where **D** & **E** join together use 4-3" nails.

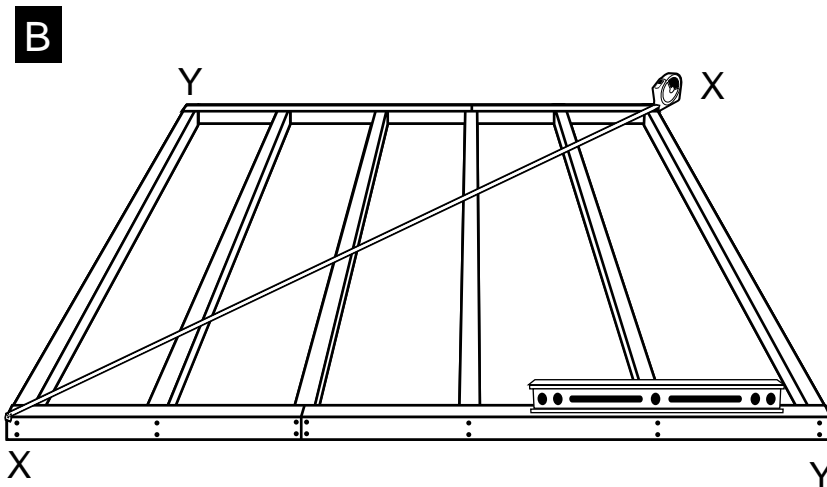

B: Completed Floor Frame should be positioned at building site, leveled, using shims between floor frame and ground before proceeding to Floor Panel Attachment.

Square frame by making corner-to-corner measurements (**X** to **X** and **Y** to **Y**) the same.

10 x 8 Floor Kit continued

FLOOR PANEL ATTACHMENT:

C: Position a 48 x 92-5/8" Floor Panel **A** flush to the outside edges of sides and back of Floor Frame. Secure panel with two 2" nails at outside corners and one 2" nail at other corners.

D: Position the other 48" x 92-5/8" Floor Panel **A** flush against first panel and flush to edges of Floor Frame. Secure panel with one 2" nail at each of the four corners.

E: Position the 23-7/8" x 92-5/8" Floor Panel **B** flush against second panel and flush to edges of Floor Frame. Secure panel with two 2" nails at outside corners and one 2" nail at each of other corners.

With Floor Panels flush to outside edges of Floor Frame, nail with 2" nails every 12" through Floor Panels into all Floor Bond Boards **D** & **E** and Floor Joists **C**.

Note: Mark a line on the Floor Panel over the center of each Floor Joist @ 24" using a pencil and a piece of lumber from the kit (or use a chalk line) to make nailing easier.

Your Floor is now complete. Check to be sure it is properly positioned and leveled to ground before beginning assembly of your Handy Home Wooden Storage Building.

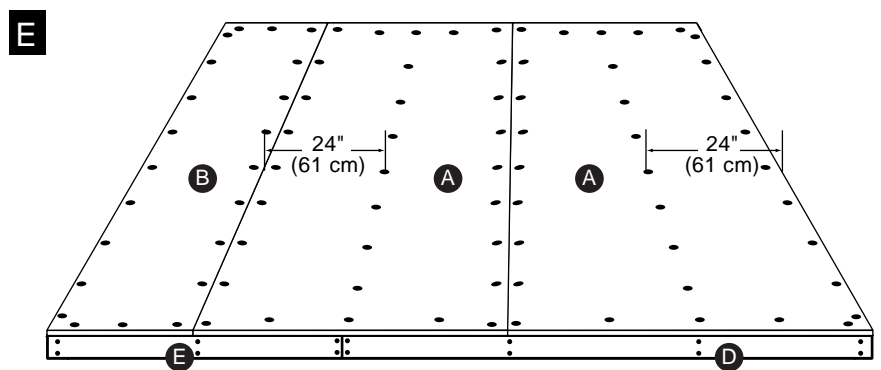
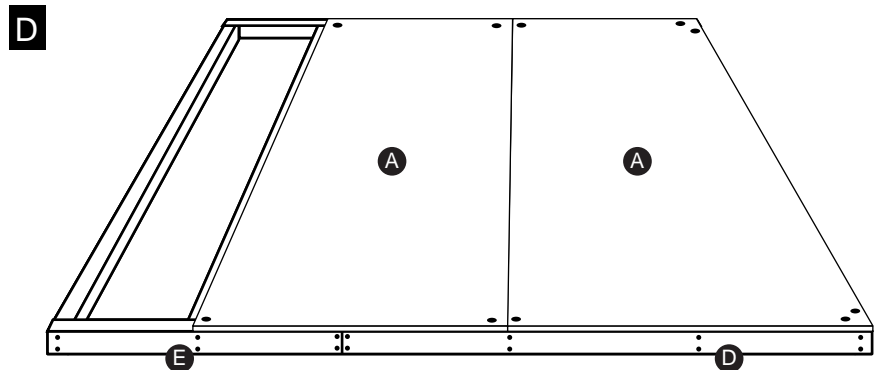
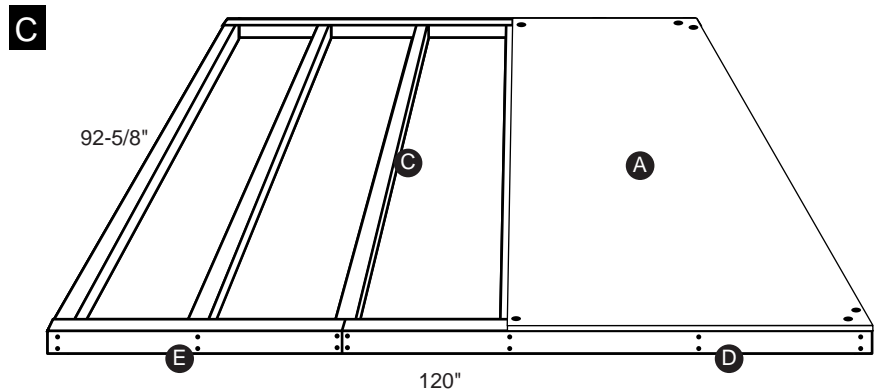

Nails every 12" (30 cm)
through Floor Panels into all
Floor Bond Boards and Joists

Phoenix 10 x 4 Floor Extender Kit Instructions

Optional Floor Kit not supplied with Building Kit. Follow instructions with Optional Floor Kit, they maybe different than this manual.

Parts Needed:

- A** 2 - 2x4x24" Bond Boards
 - B** 2 - 2x4x96" Bond Boards
 - C** 6 - 2x4x42-1/2" Floor Joist
 - D** 1 - 45-1/2"x96"x5/8" Floor Panels
 - E** 1 - 23-7/8"x45-1/2"x5/8" Floor Panels
- 2" and 3" Nails

Note: Floor Kit parts are not stamped with identification letters.

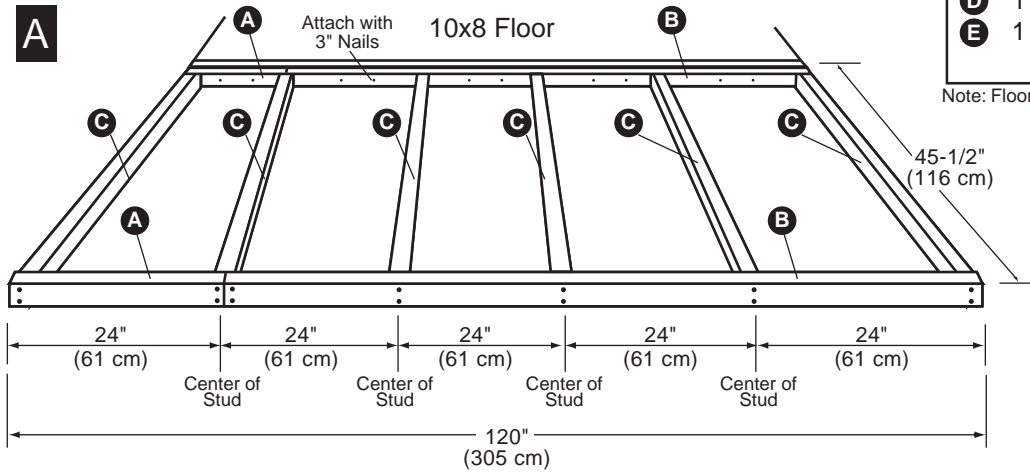

A: Position Bond Boards **A** & **B** and Floor Joists **C** as shown.

Using 3" nails, nail twice through each Bond Board **A** & **B** into each end of each Joist **C**, keeping pieces flush at top and ends, and maintain 24" spacing as shown. Where **A** & **B** join together use 4-3" nails.

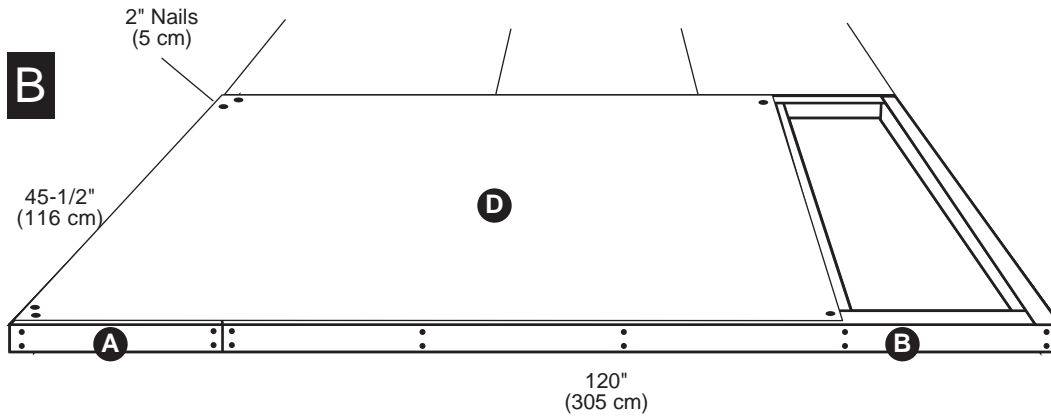

B: Position a 45-1/2" x 96" Floor Panel **D** flush to the outside edges of sides and back of Floor Frame. Secure panel with two 2" nails at outside corners and one 2" nail at other corners.

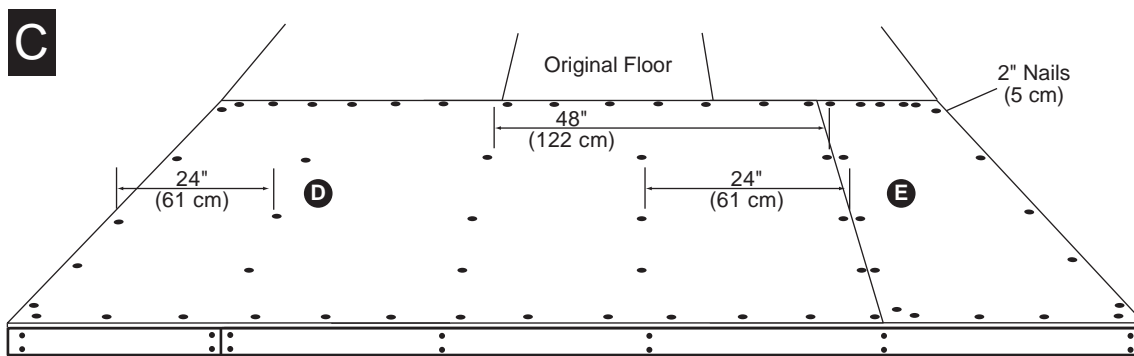

Nails every 12" (30 cm) through Floor Panels into all Floor Bond Boards and Floor Joists

C: Position a 23-7/8" x 45-1/2" Floor Panel **E** flush against first panel and flush to edges of Floor Frame. Secure panel with two 2" nails at outside corners and one 2" nail at other corners.

Note: Mark a line on the Floor Panel over the center of each Floor Joist using a pencil and a piece of lumber from the kit (or use a chalk line) to make nailing easier.

With Floor Panels flush to outside edges of Floor Frame, nail with 2" nails every 12" through Floor Panels into all Floor Bond Boards and Floor Joists.

Your Floor is now complete. Check to be sure it is properly positioned and leveled to ground before beginning assembly of your Wooden Storage Building.

1 No Door Side Wall Assembly

□ 2	TN	-----	2 x 4 x 79 ¹ / ₄ "	5 x 10 x 201cm
□ 8	TH	-----	2 x 4 x 69 ¹ / ₂ "	5 x 10 x 176cm
□ 4	TG	-----	2 x 4 x 56 ¹ / ₂ "	5 x 10 x 143cm
□ 2	SN	-----	2 x 4 x 43 ³ / ₄ "	5 x 10 x 111cm
□ 4	SD	-----	2 x 4 x 33"	5 x 10 x 84cm
□ 2	¹ / _{1R} Angled wall Panel		48" x 72"	122 X 183cm
□ 2	-- Wall Panel		48" x 72"	122 X 183cm
□ 2	-- Narrow Wall Panel		23 ⁷ / ₈ " x 72"	60.6 X 183cm

Note: Before beginning assembly, Door Placement, Optional Window Placement, and Building Size must be determined.

Refer to page 2 & 3 before beginning assembly.

1A. Arrange 1- TN, 4- THs, 1- SN, 2- SDs, and 2-TGs as shown.

A Nail parts together using two 3" (6.7cm) nails at each connection.

B Be sure to nail both TGs together as shown using one 3" (6.7cm) nail.

This Parts List contains enough parts to build 1-Left and 1-Right Side Wall Panel.

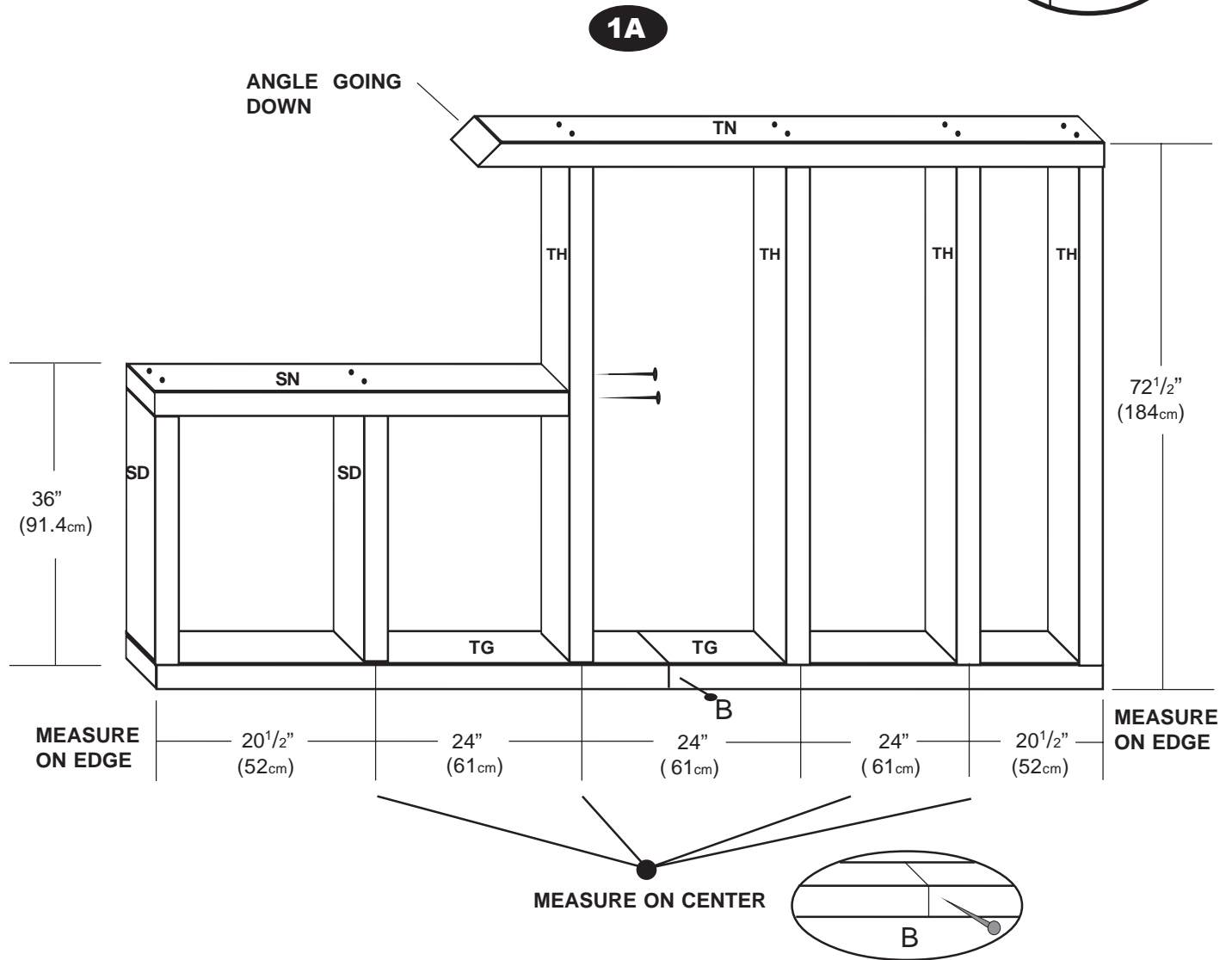
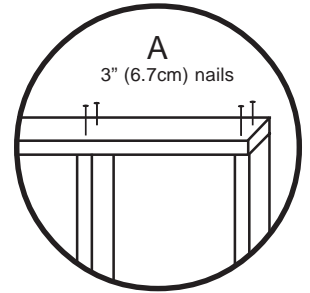

Side Wall Assembly Cont.

Right side wall assembly shown. If building Left side assembly, place wall panels on opposite side of frame.

1B. Install First Panel 23⁷/₈" x 72" (60.6x183cm) as shown.

Nail, and follow sequence shown with four 2" (5cm) nails.

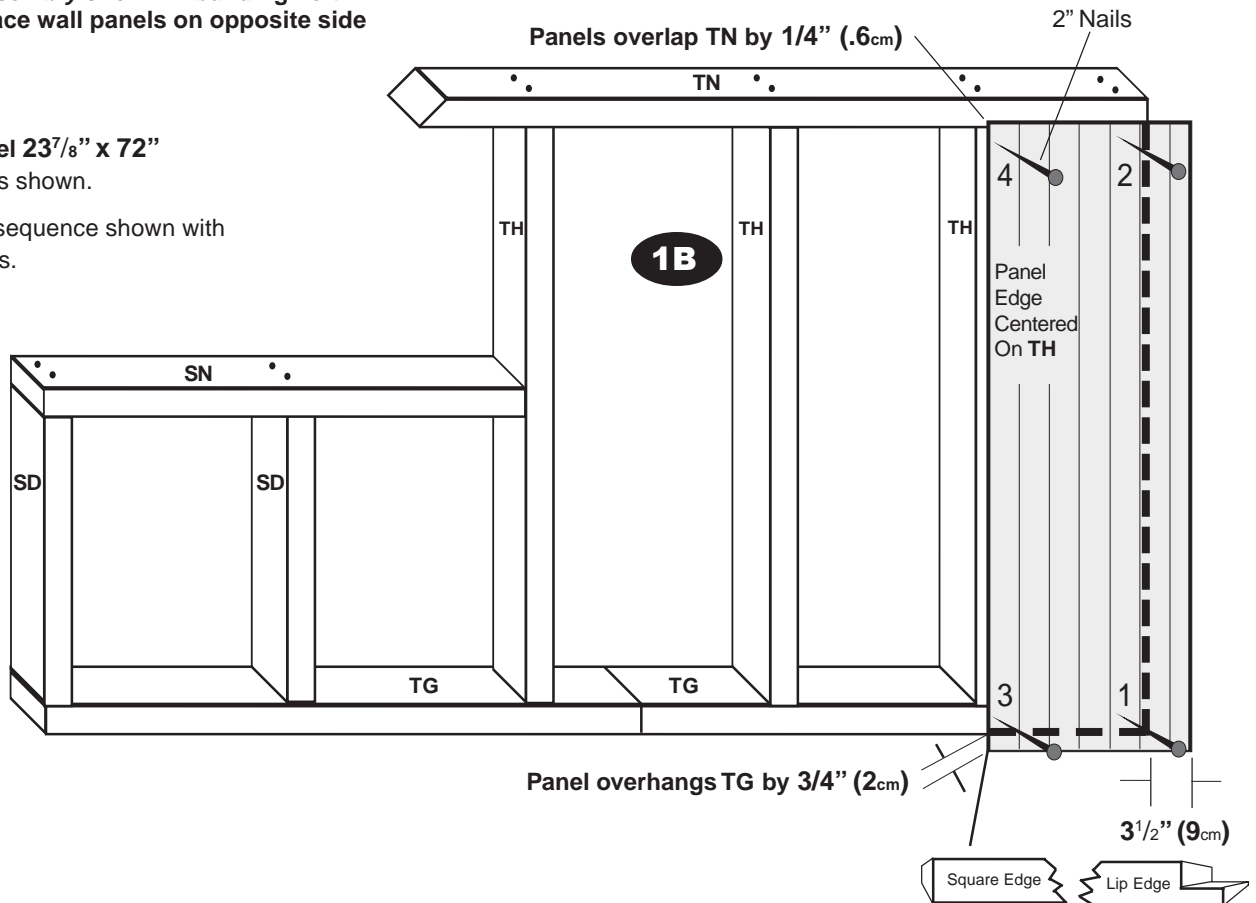

1C. Install Second Panel 48" x 72" (122x183cm) as shown.

Nail, and follow sequence shown with four 2" (5cm) nails.

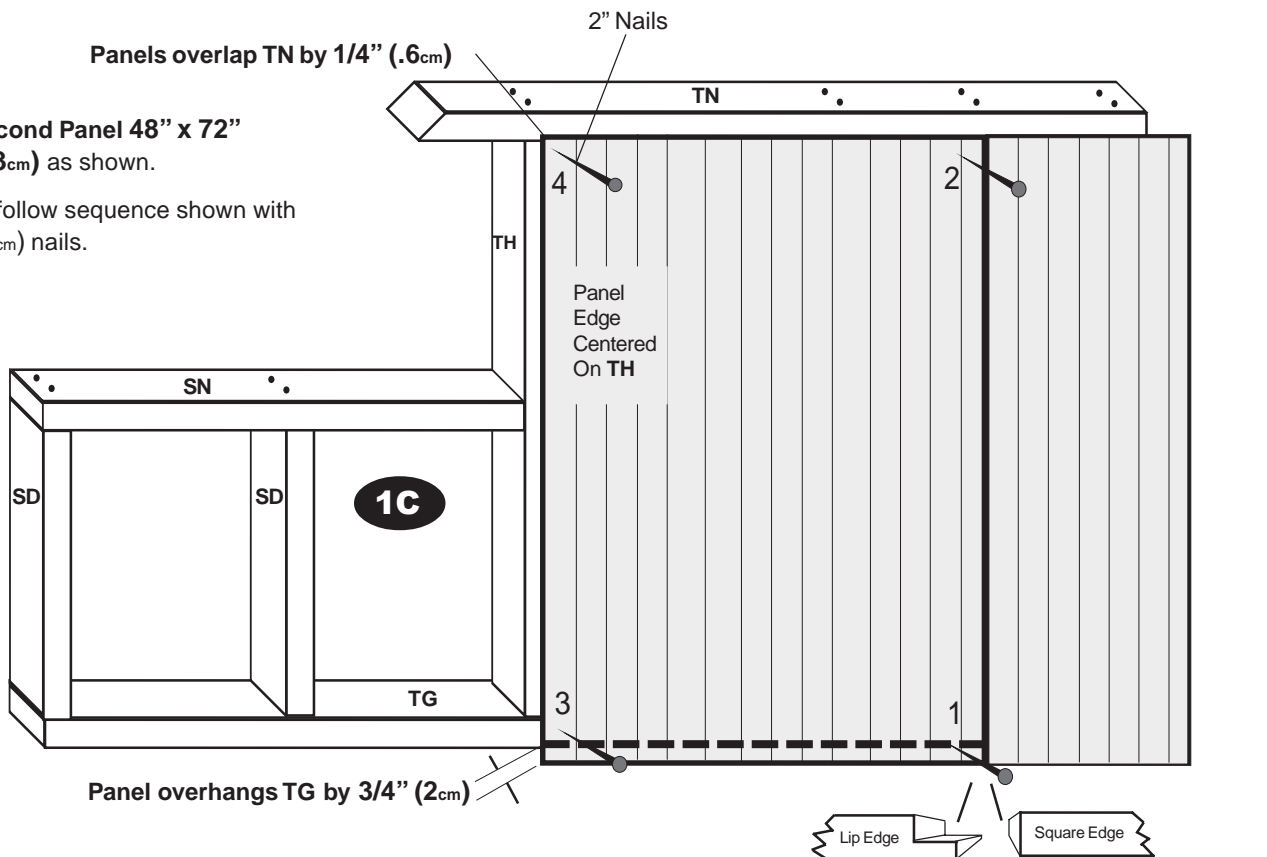

Side Wall Assembly Cont.

1D. Install Angled Panel 48"x72"
(122x183cm) as shown.

Nail, and follow sequence shown with
four 2" (5cm) nails.

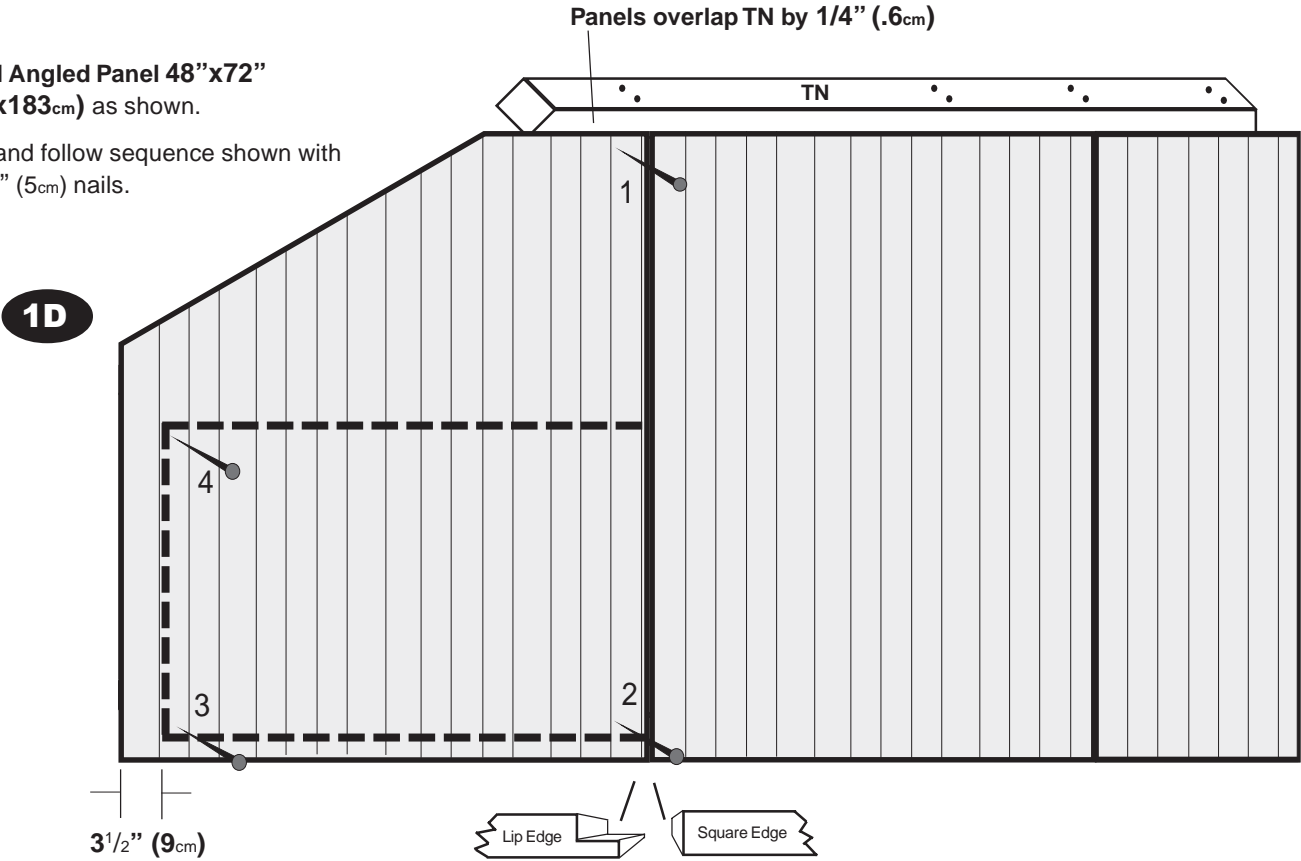

1E. Once all panels are in place
secure to frame using 2" (5cm)
nails spaced every 8" (20cm).

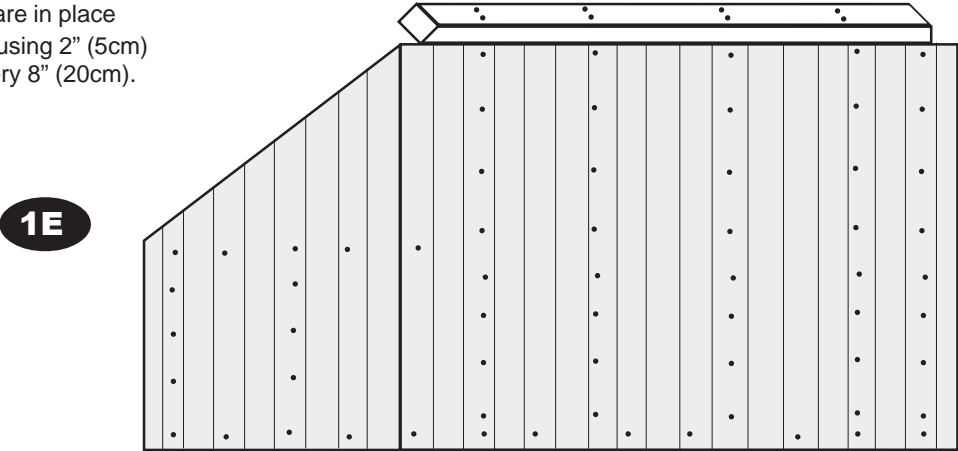

With Door

1 Side Wall Assembly

□ 1	TN	-----	2 x 4 x 79 ¹ / ₄ "	5 x 10 x 201cm
□ 4	TH	-----	2 x 4 x 69 ¹ / ₂ "	5 x 10 x 176cm
□ 2	TG	-----	2 x 4 x 56 ¹ / ₂ "	5 x 10 x 143cm
□ 1	SN	-----	2 x 4 x 43 ³ / ₄ "	5 x 10 x 111cm
□ 2	SD	-----	2 x 4 x 33"	5 x 10 x 84cm
□ 1	¹ / _L ¹ / _R	Angled wall Panel	48" x 72"	122 X 183cm
□ 1	--	Wall Panel	14 ³ / ₈ " x 72"	36 X 183cm
□ 1	--	Narrow Wall Panel	23 ⁷ / ₈ " x 72"	60.6 X 183cm
□ 1	SC	-----	2 x 4 x 32"	5 x 10 x 81.3cm

Note: Before beginning assembly, Determine Door Location per illustrations on Page 2.

This Parts List contains enough parts to build 1 Side Wall.

1A. Arrange 1- **TN**, 4- **TH**s, 1- **SN**, 2- **SD**s, 1- **SC** and 2- **TG**s as shown.

A Nail parts together using two 3" (6.7cm) nails at each connection.

B Be sure to toe-nail both **TG**s together as shown using one 3" (6.7cm) nail.

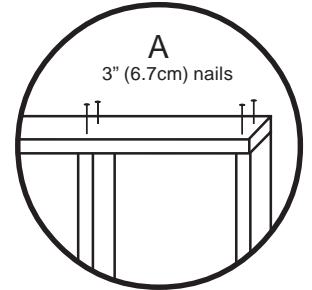

1A

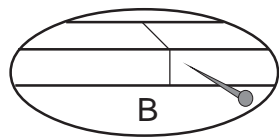
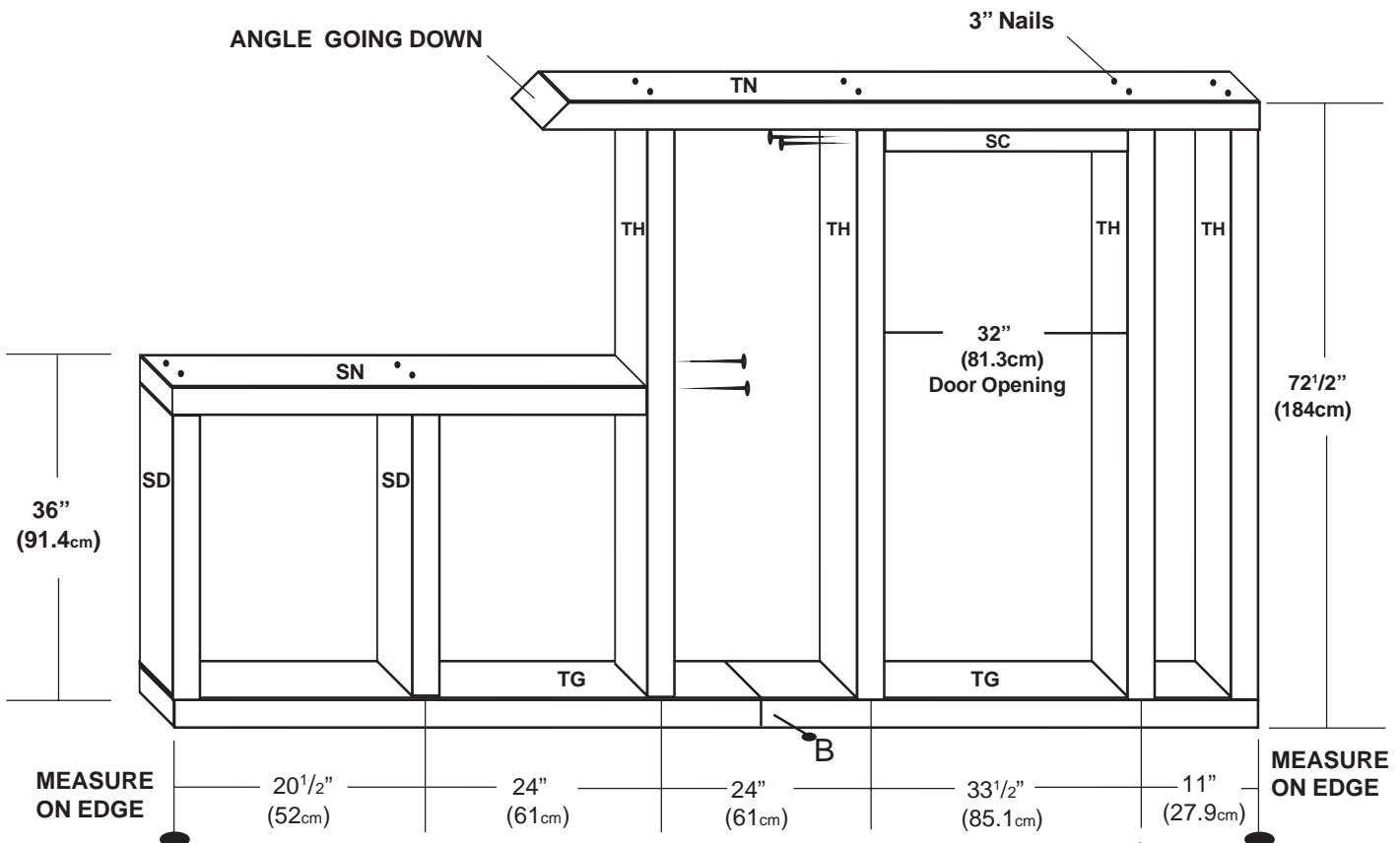

Side Wall Assembly Cont.

Right side wall assembly shown. If building left side assembly, place wall panels on opposite side of frame.

1B. Install First Panel 14³/₈" x 72"
(36x183cm) as shown.

Nail, and follow sequence shown with four 2" (5cm) nails.

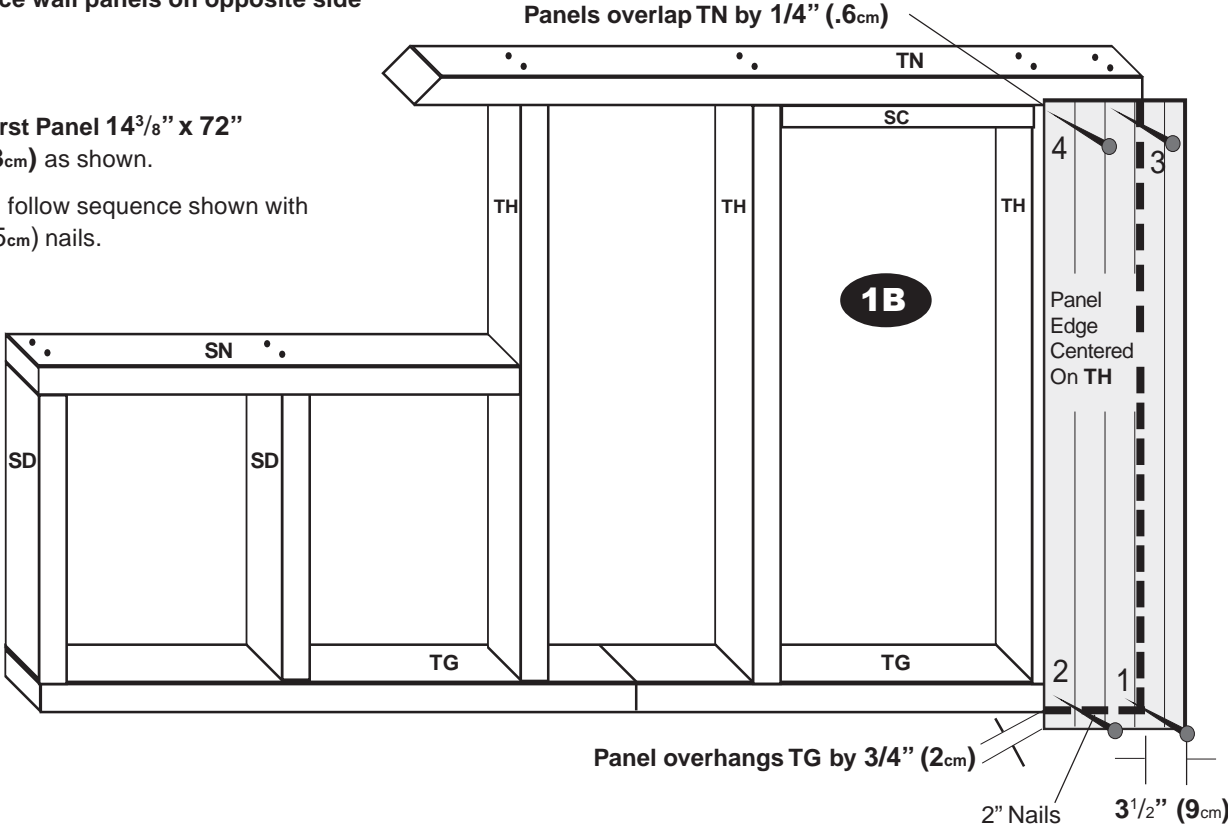

1C. Install Second Panel 23⁷/₈" x 72"
(60.6x183cm) as shown.

Nail and follow sequence shown with four 2" (5cm) nails.

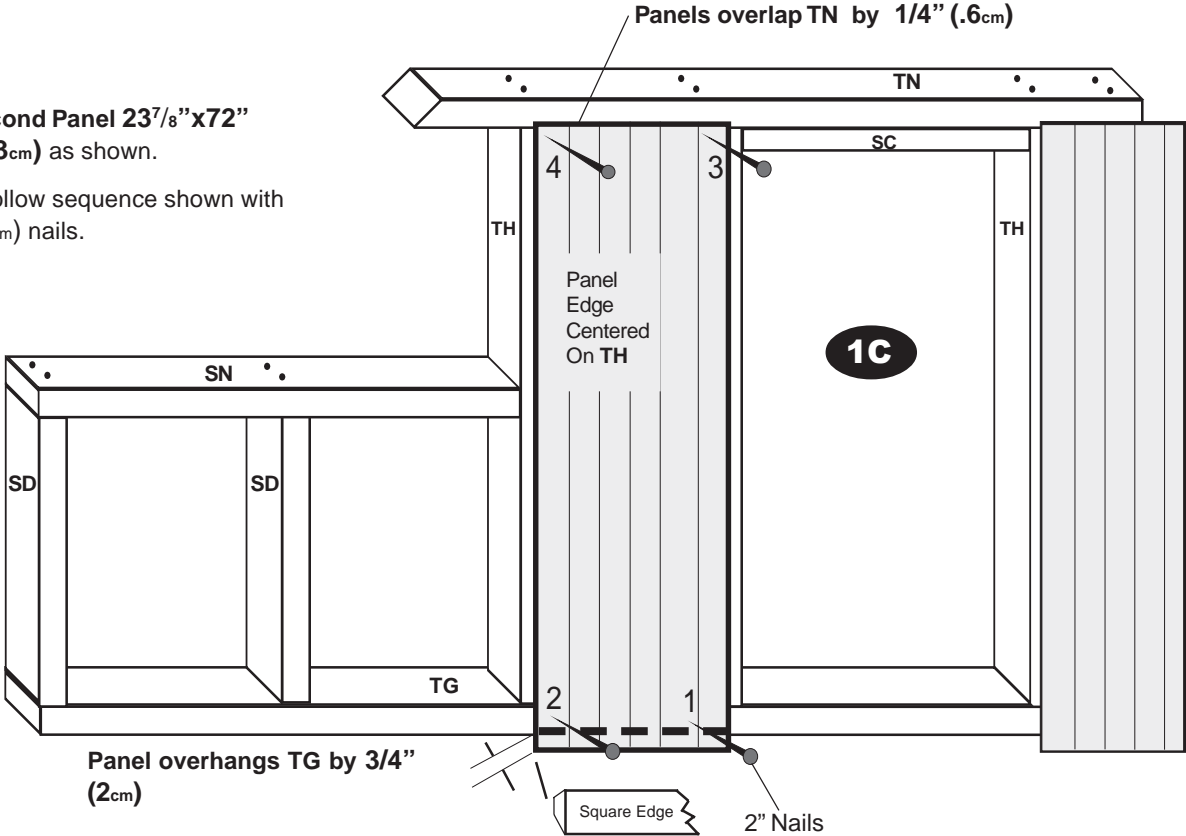

**1D. Install Angled Panel 48"x72"
(122x183cm) as shown.**

Nail, and follow sequence shown with
four 2" (5cm) nails.

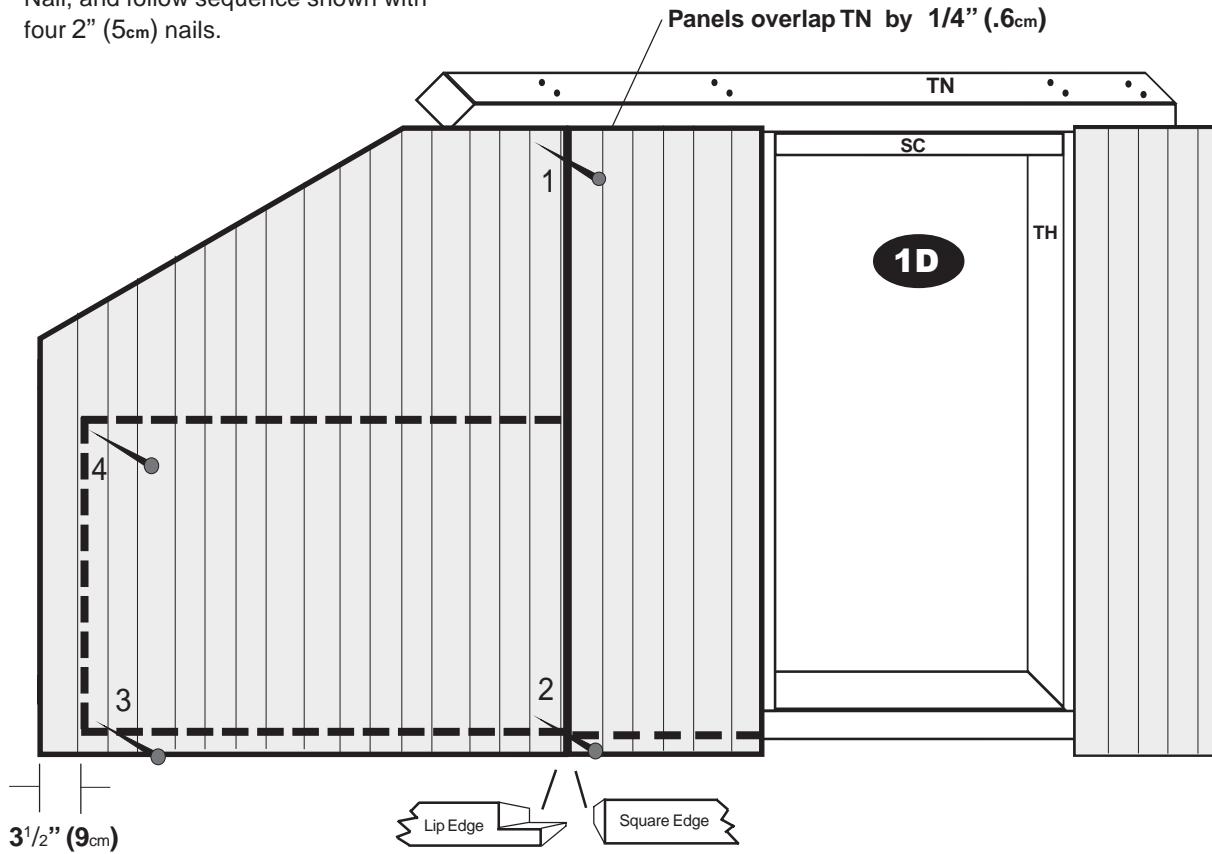

**1E. Once all panels are in place
secure to frame using 2" (5cm)
nails spaced every 8" (20cm).**

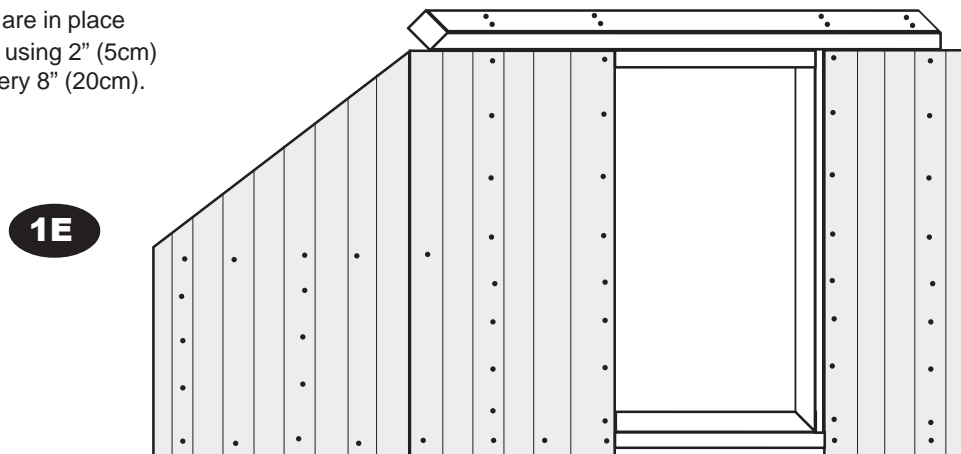

2 Short Wall Assembly

□ 1	VO	-----	2 x 6 x 92 ⁵ / ₈ "	5 x 14 x 235cm
□ 1	UL	-----	2 x 4 x 92 ⁵ / ₈ "	5 x 10 x 235cm
□ 5	SD	-----	2 x 4 x 33"	5x 10 x 84cm
□ 1	2B*	Wall Panel	44 ³ / ₈ " x 35 ¹ / ₄ "	113 x 89cm
□ 1	2C*	Wall Panel	48" x 35 ¹ / ₄ "	122 x 89cm

* Refers To Step Panel Is Used

2A. Arrange 1- VO, 5- SDs and, 1-UL as shown.

A Nail parts together using two 3" (6.7cm) nails at each connection.

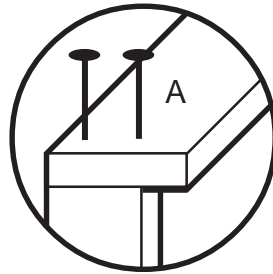

2A

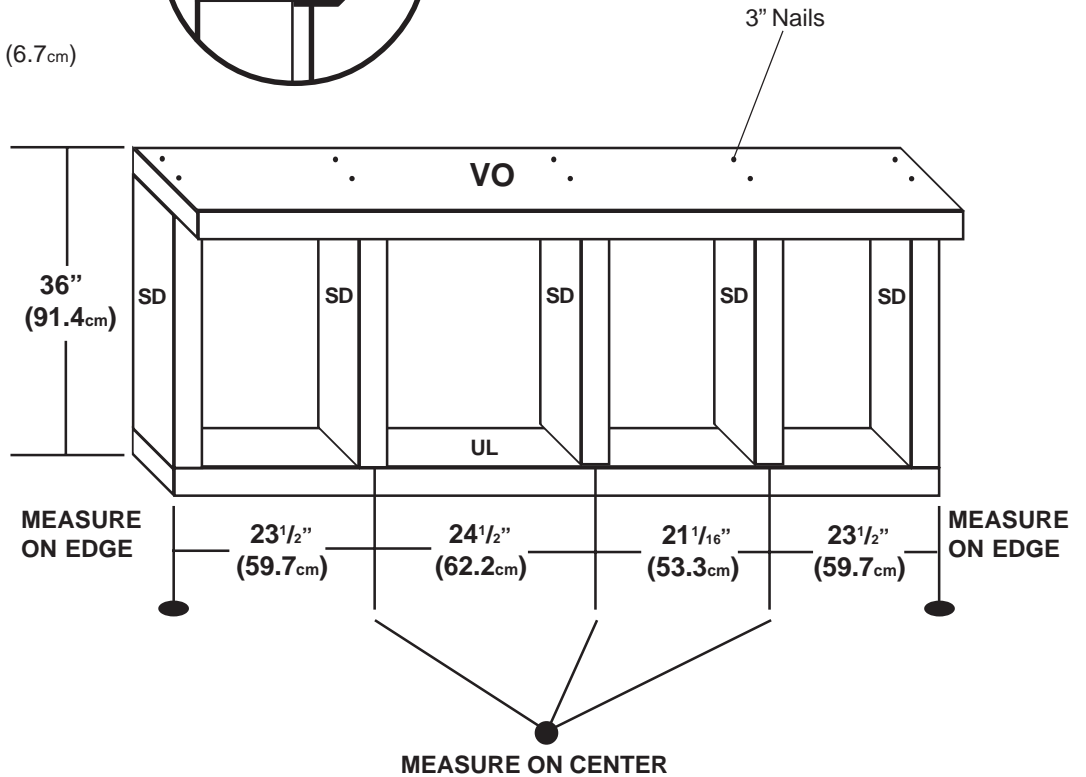

2B. Install First Panel 44³/₈"x35¹/₄" (113x183cm) as shown.

Nail, and follow sequence shown with four 2" (5cm) nails.

2B

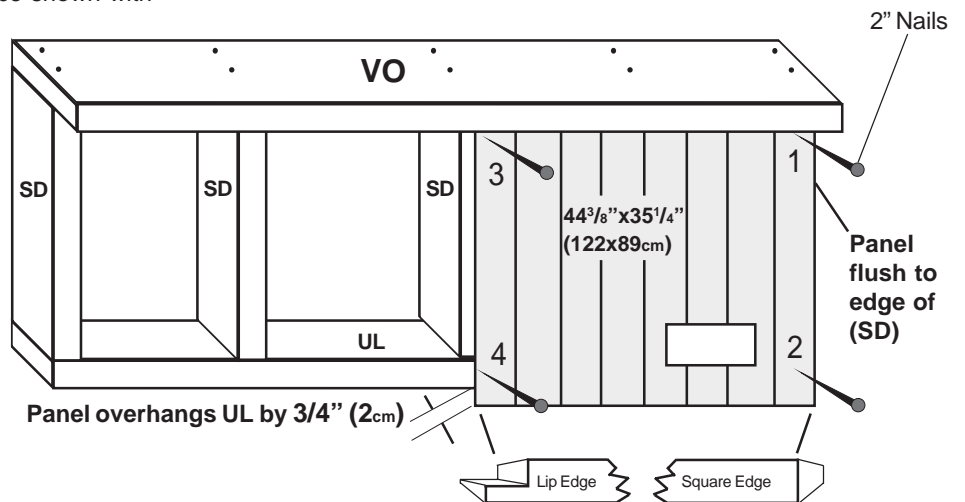

Short Wall Assembly Cont.

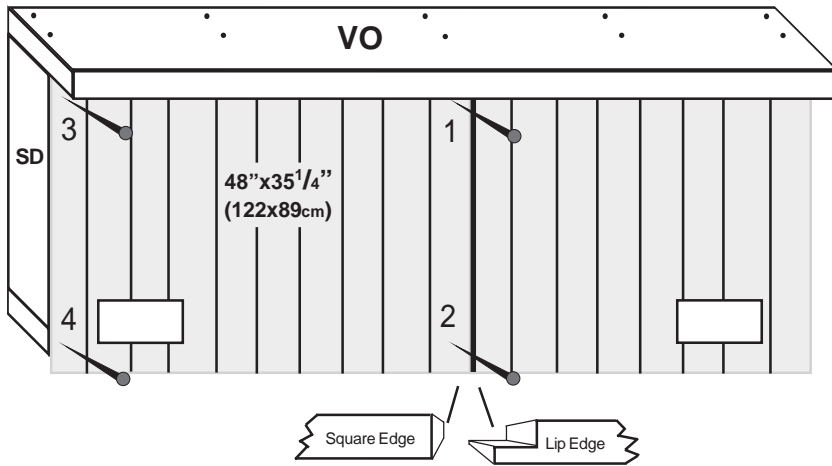

2C. Install **Second Panel 48"x35¹/₄" (122x89cm)** as shown.

Nail, and follow sequence shown with four 2" (5cm) nails.

2C

2D

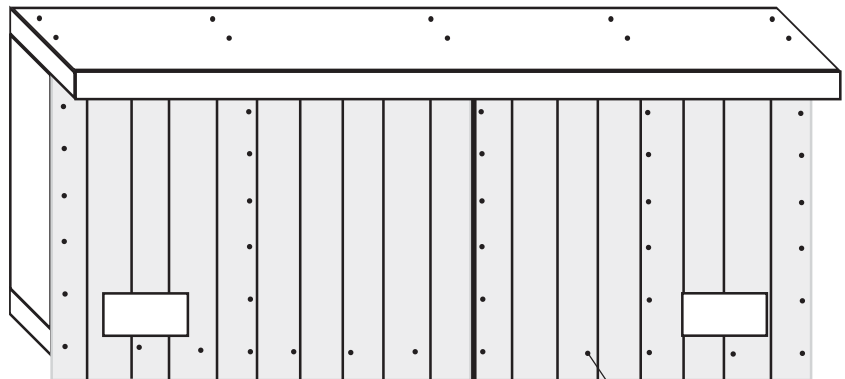

2D. Once all panels are in place secure to frame using 2" (5cm) nails spaced every 8" (20cm).

2" Nails
every 8"

2 Extended Short Wall Assembly

12' Long Wall

□ 1 VO		2 x 6 x 92 ⁵ / ₈ "	5 x 14 x 235cm
□ 1 VD		2 x 6 x 45 ¹ / ₂ "	5 x 14 x 115.5cm
□ 8 SD		2 x 4 x 33"	5 x 10 x 83.8cm
□ 1 UL		2 x 4 x 92 ⁵ / ₈ "	5 x 10 x 235cm
□ 1 SR		2 x 4 x 45 ¹ / ₂ "	5 x 10 x 115.5cm
□ 1 2B*	Wall Panel	45 ¹ / ₂ " x 35 ¹ / ₄ "	115.5 x 89cm
□ 1 2C*	Wall Panel	44 ³ / ₈ " x 35 ¹ / ₄ "	113 x 89cm
□ 1 2D*	Wall Panel	48" x 35 ¹ / ₄ "	122 x 89cm

* Refers To Step Panel Is Used

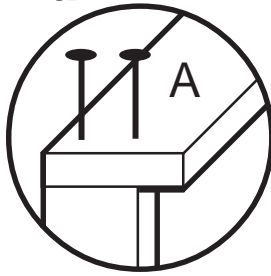

2A. Arrange 1- VO, 1- VD, 8 - SDs, 1- TJ and, 1 - SR as shown.

A Nail parts together using two 3" (6.7cm) nails at each connection.

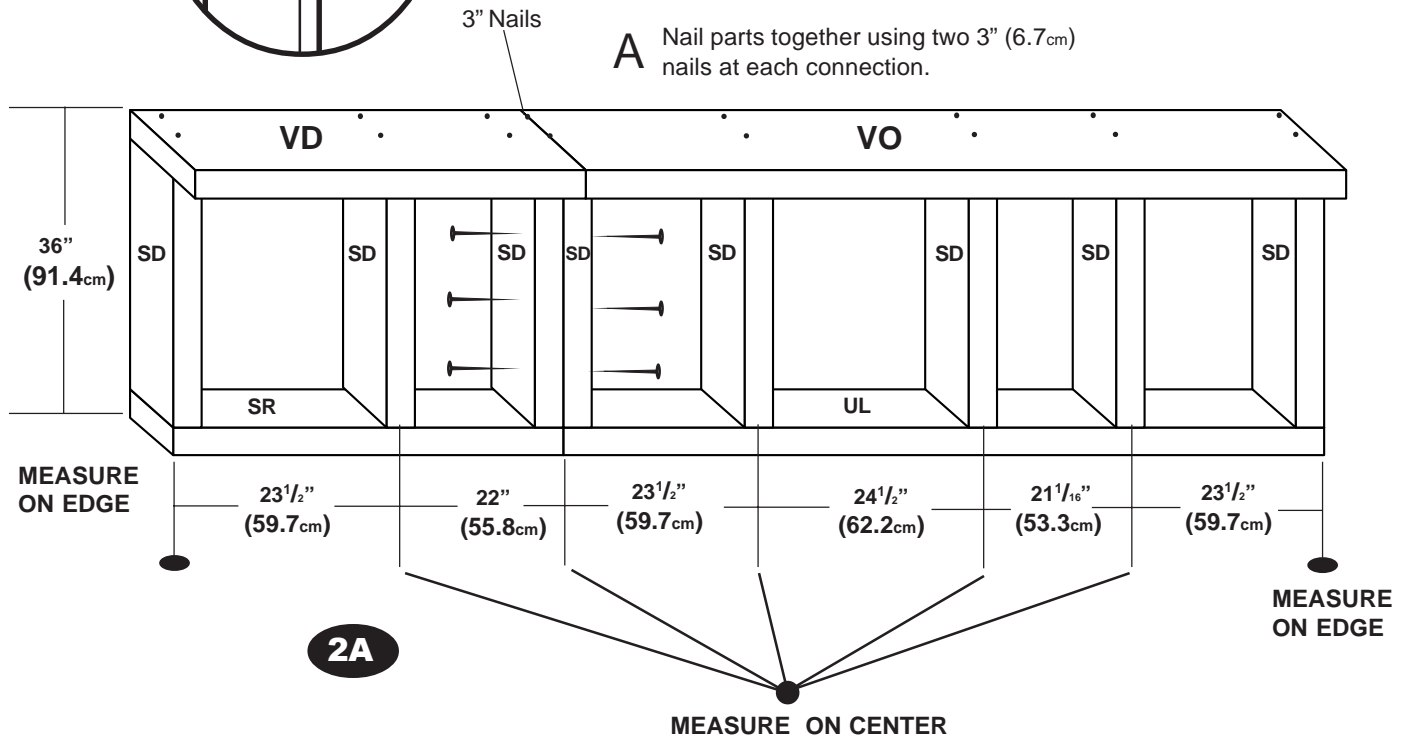

2B. Install First Panel 44³/₈"x35¹/₄" (113x83cm) as shown.

Nail, and follow sequence shown with four 2" (5cm) nails.

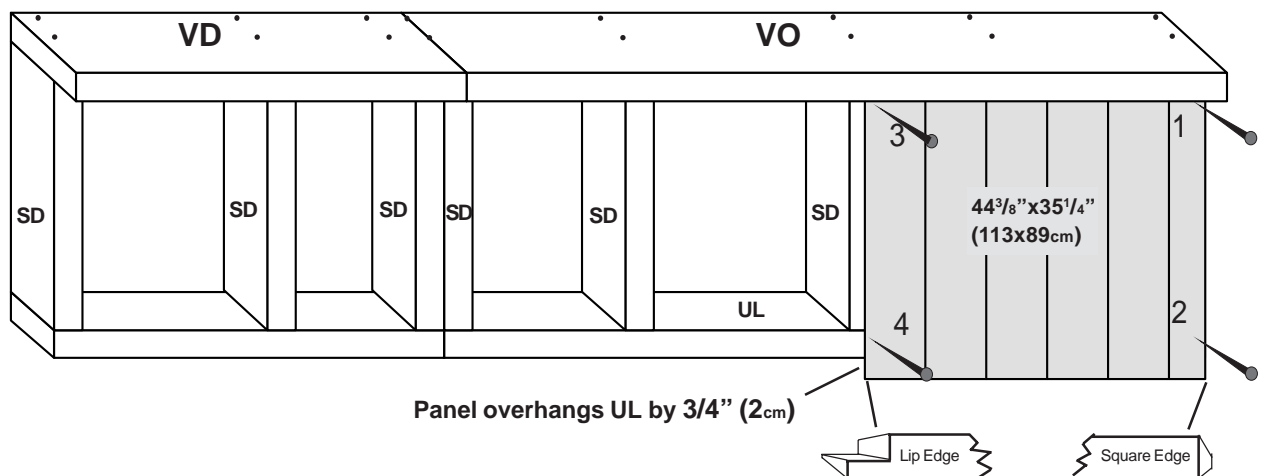

2C. Install Second Panel 48"x35 1/4"
(122x89cm) as shown.

Nail, and follow sequence shown with four 2" (5cm) nails.

2C

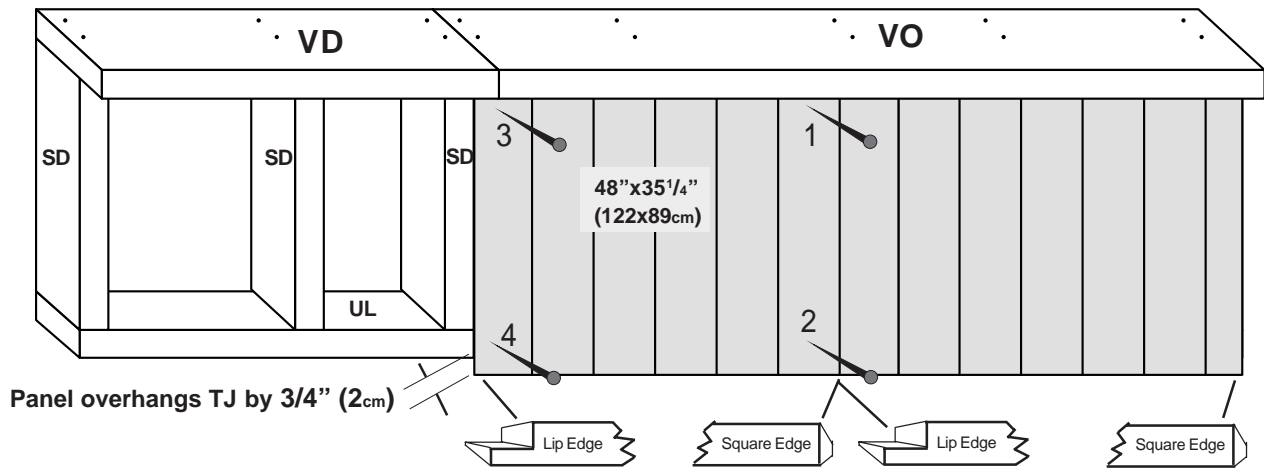

2D. Install Third Panel 45 1/2"x35 1/4"
(116x89cm) as shown.

Nail, and follow sequence shown with four 2" (5cm) nails.

2D

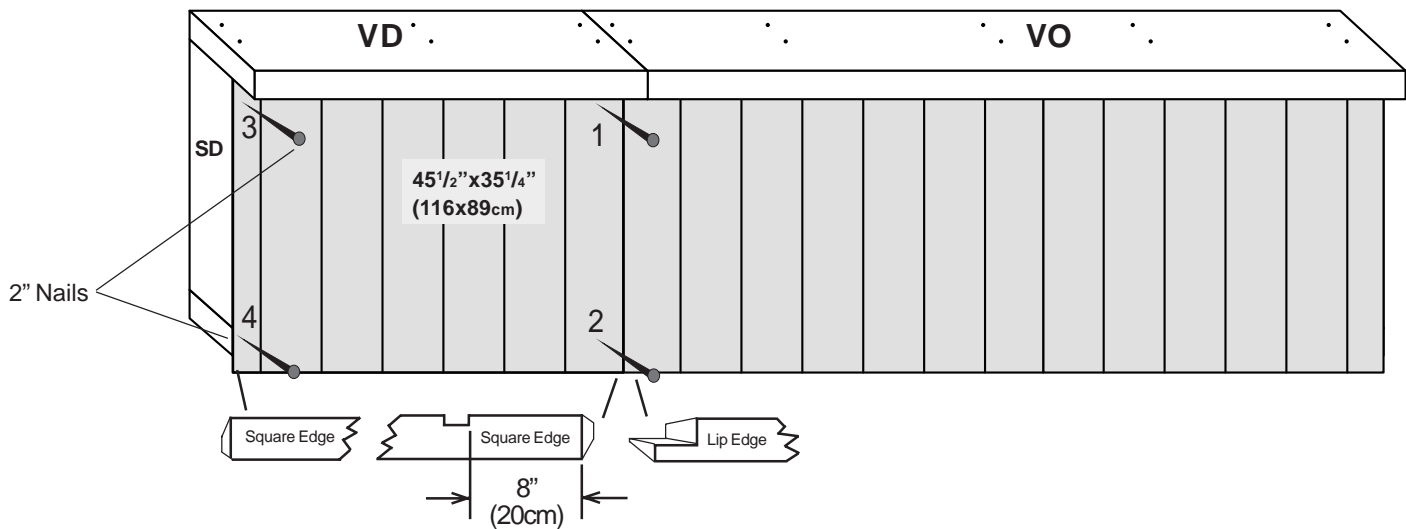

2E. Once all panels are in place secure to frame using 2" (5cm) nails spaced every 8" (20cm).

2E

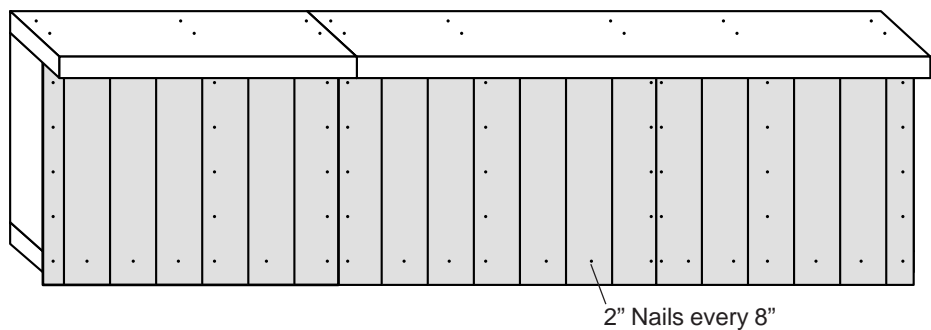

2 Extended Short Wall

Assembly 16' Long Wall

□ 11 SD		2 x 4 x 33"	5 x 10 x 83.8cm
□ 1 VO		2 x 6 x 92 ⁵ / ₈ "	5 x 14 x 235cm
□ 1 UL		2 x 4 x 92 ⁵ / ₈ "	5 x 10 x 235cm
□ 2 VD		2 x 6 x 45 ¹ / ₂ "	5 x 14 x 115.5cm
□ 2 SR		2 x 4 x 45 ¹ / ₂ "	5 x 10 x 115.5cm
□ 1 2C*	Wall Panel	48-3/8 x 35-1/4"	122 x 89.5cm
□ 1 2C*	Wall Panel	44-3/8" x 35-1/4"	113 x 89.5cm
□ 2 2B,D*	Wall Panel	45-1/2" x 35-1/4"	116 x 89.5cm

* Refers To Step Panel is Used

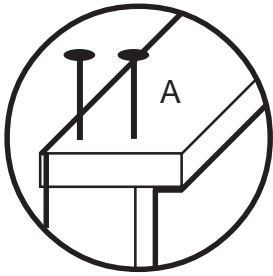

2A. Arrange 1- VO, 2 - VD, 11 - SDs, 1- UL and, 2 - SR as shown.

A Nail parts together using two 3" (6.7cm) nails at each connection.

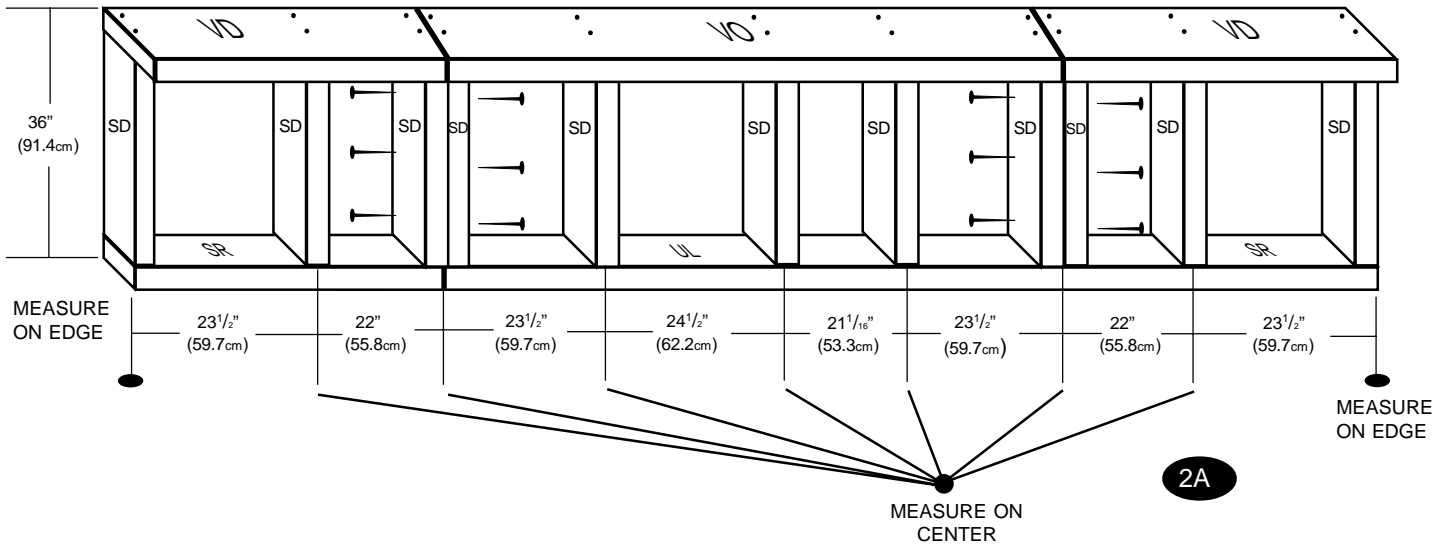

16' Short Wall Cont.

**2B. Install First Panel $45\frac{1}{2}'' \times 35\frac{1}{4}''$
(116x183cm) as shown.**

Nail, and follow sequence shown with four 2" (5cm) nails.

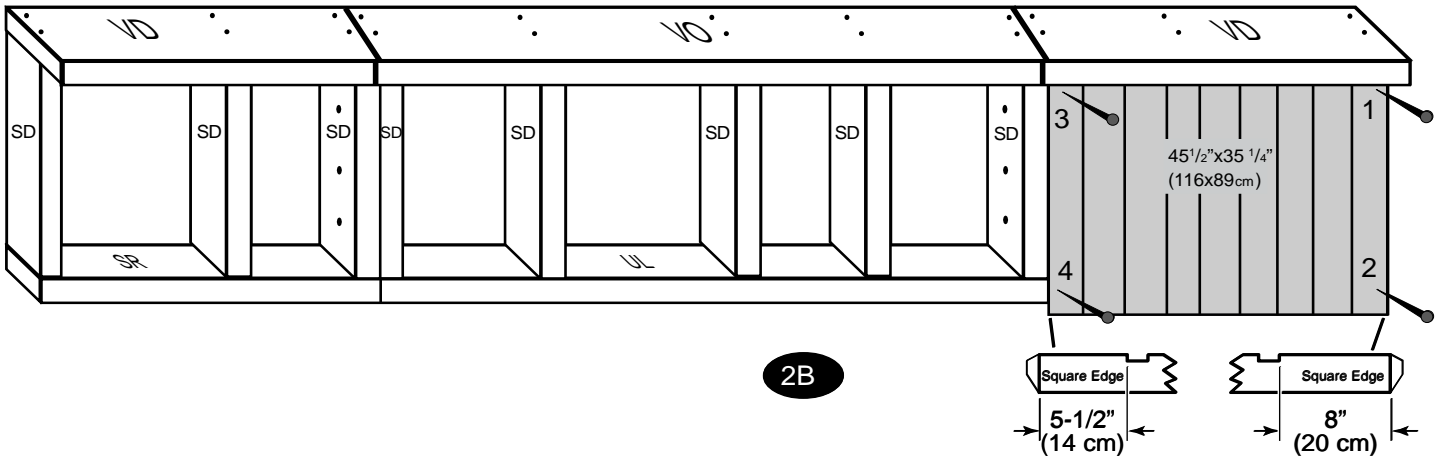

**2C. Install Second Panel $44\frac{3}{8}'' \times 35\frac{1}{4}''$
(113x183cm) and Third Panel $48'' \times 35\frac{1}{4}''$
(122x183cm) as shown.**

Nail, and follow sequence shown with four 2" (5cm) nails.

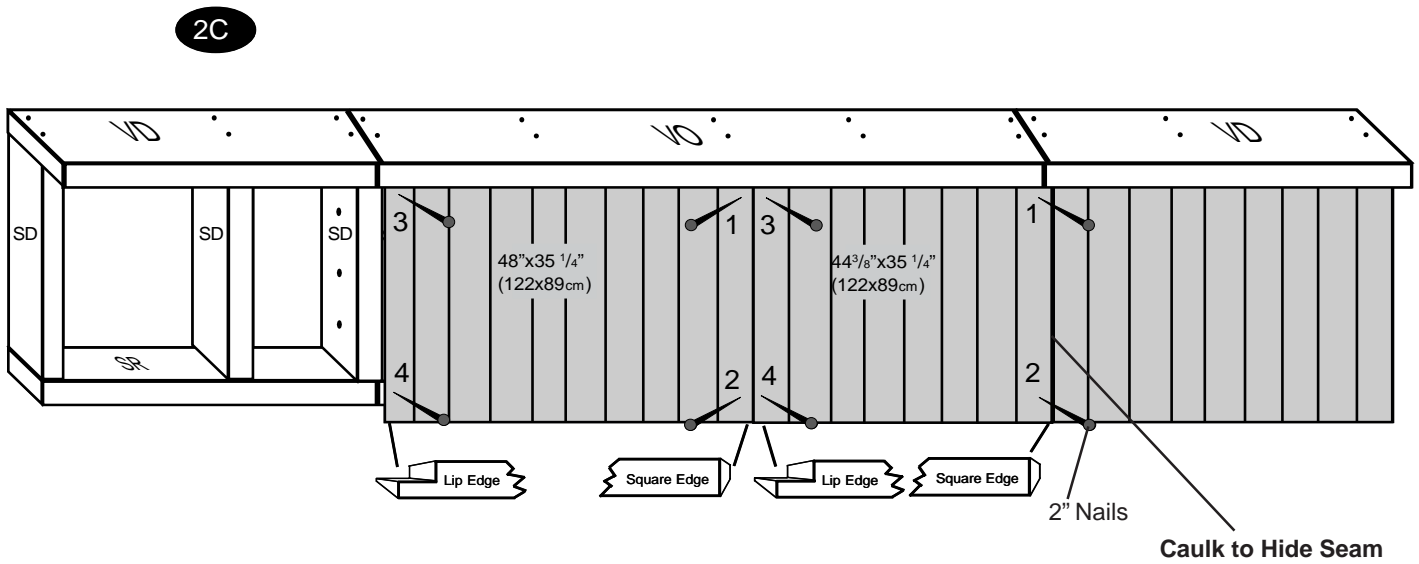

16' Short Wall Cont.

2D. Install **Fourth Panel 45 1/2" x 35 1/4"**
(116x89cm) as shown.

Nail, and follow sequence shown with
four 2" (5cm) nails.

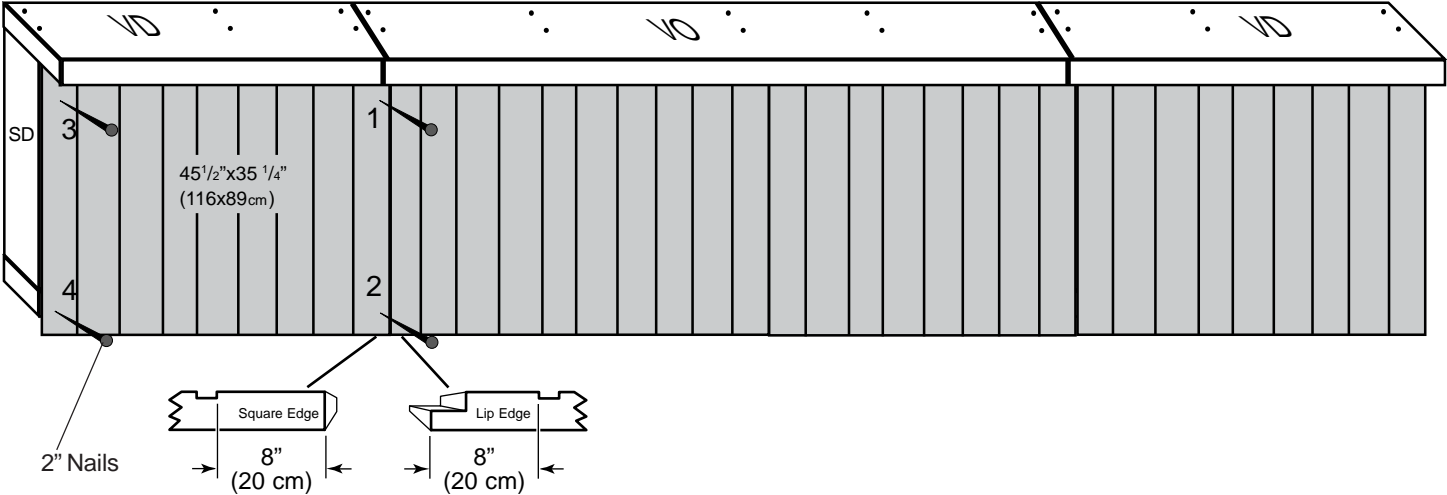

2E. Once all panels are in place
secure to frame using 2" (5cm)
nails spaced every 8" (20cm).

2E

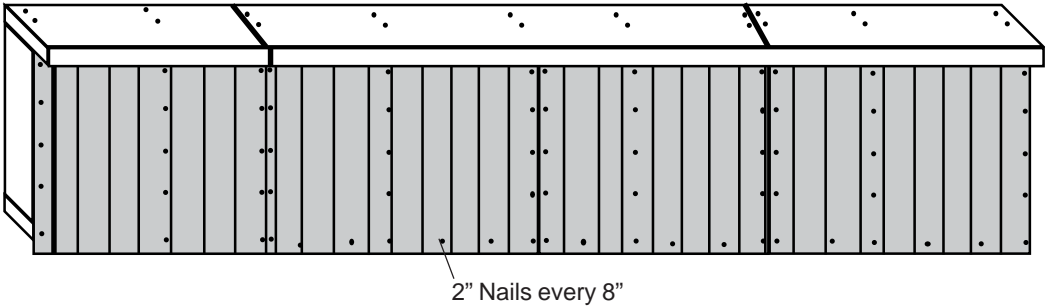

No Door

3 Tall Wall Assembly

□ 1 VO	Top Plate	2 x 6 x 92 ⁵ / ₈ "	5 x 14 x 235cm
□ 5 TH	Wall Stud	2 x 4 x 69 ¹ / ₂ "	5 x 10 x 176cm
□ 1 UL	Bottom Plate	2 x 4 x 92 ⁵ / ₈ "	5 x 10 x 235cm
□ 1 3B*	Wall Panel	44 ³ / ₈ " x 72"	113 x 183cm
□ 1 3C*	Wall Panel	48" x 72"	122 x 183cm

* Refers To Step Panel Is Used

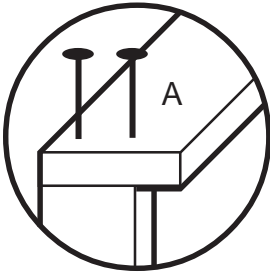

3A. Arrange 1- VO, 5- THs and, 1-UL as shown.

A Nail parts together using two 3" (6.7cm) nails at each connection.

3A

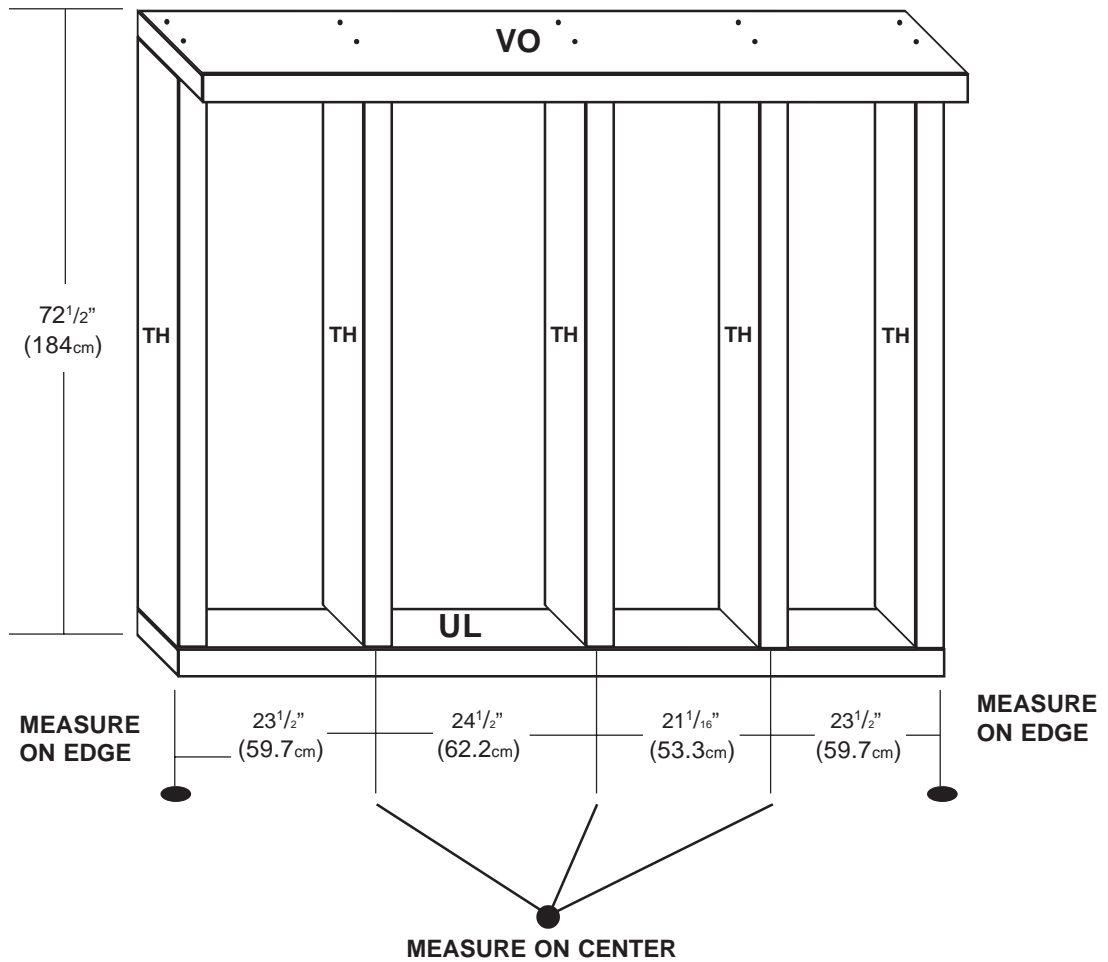

Tall Wall cont.

3B. Install First Panel 44³/₈"x72" (113x183cm) as shown.

Nail, and follow sequence shown with four 2" (5cm) nails.

3B

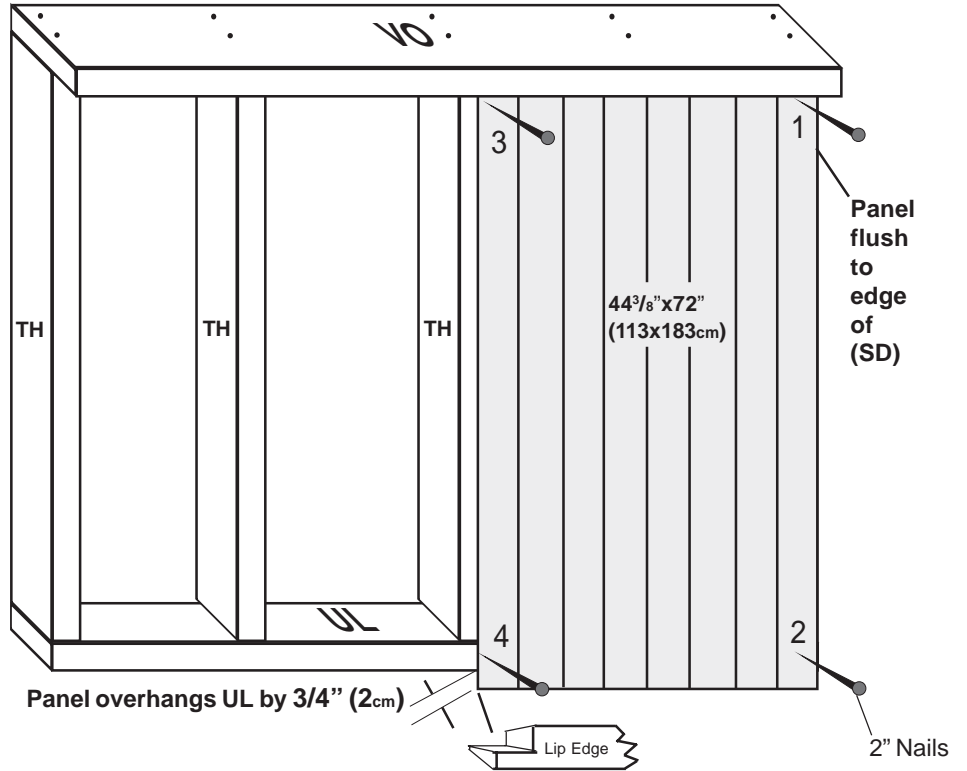

3C. Install Second Panel 48"x72" (122x183cm) as shown.

Nail, and follow sequence shown with four 2" (5cm) nails.

3C

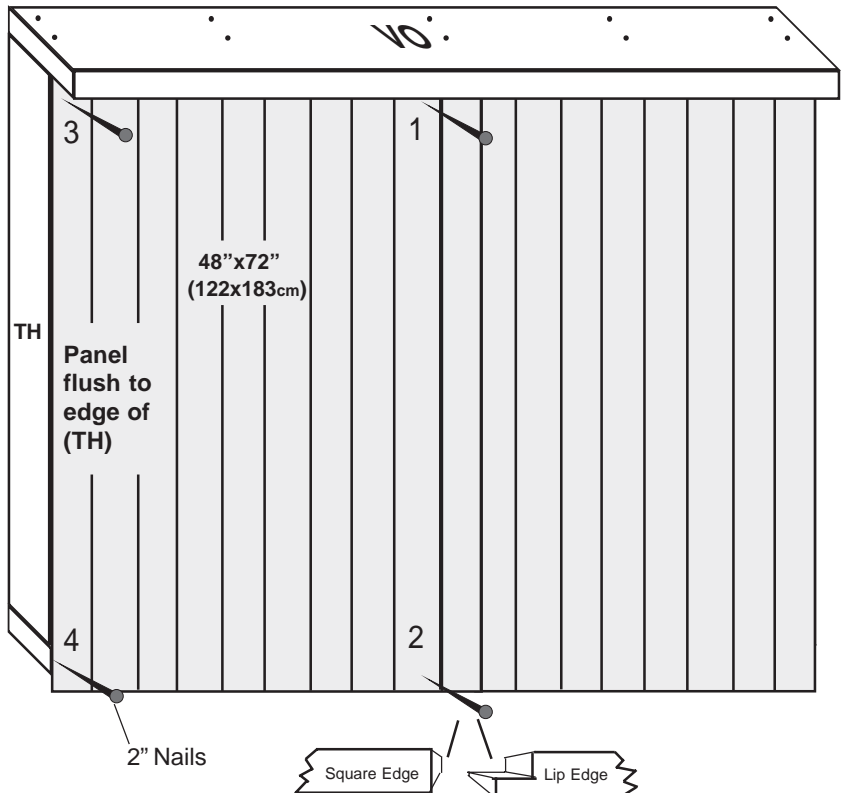

Tall Wall cont.

- 3D.** Once all panels are in place secure to frame using 2" (5cm) nails spaced every 8" (20cm).

3D

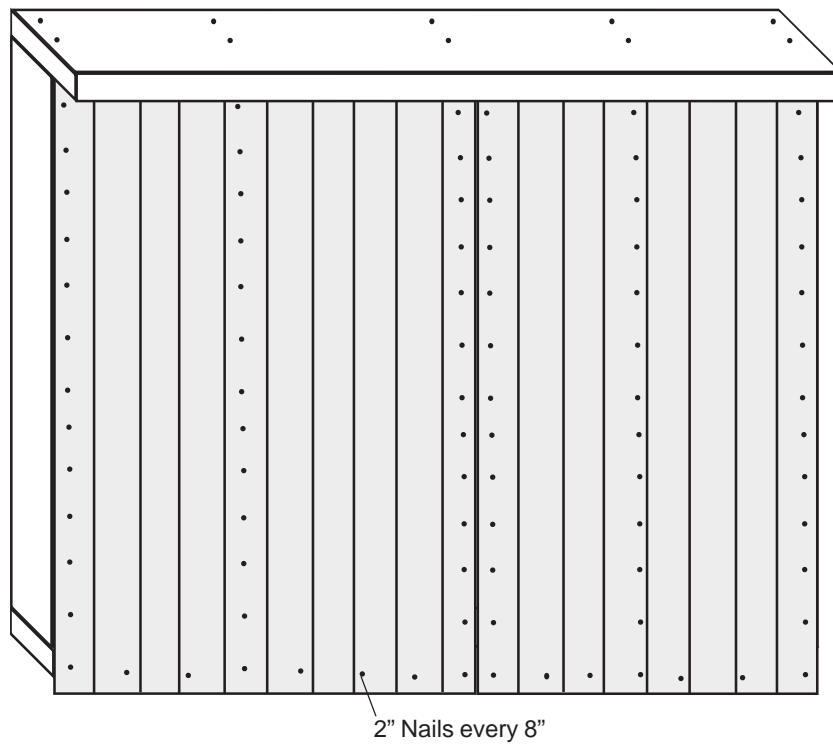

3 Tall Wall Assembly with Door

□ 1 VO	Top Plate	2 x 6 x 92 ⁵ / ₈ "	5 x 14 x 235cm
□ 5 TH	Wall Stud	2 x 4 x 69 ¹ / ₂ "	5 x 10 x 176cm
□ 1 UL	Bottom Plate	2 x 4 x 92 ⁵ / ₈ "	5 x 10 x 235cm
□ 1 3B*	Wall Panel	14 ³ / ₈ " x 72"	36 x 183cm
□ 1 3C*	Wall Panel	44 ³ / ₈ " x 72"	112.7 x 183cm
□ 1 SC		2 x 4 x 32"	5 x 10 x 81.3cm

* Refers To Step Panel Is Used

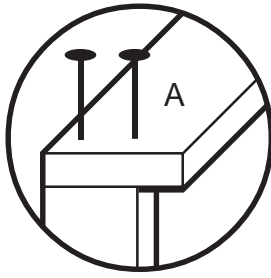

3A. Arrange 1- VO, 5- THs, 1-SC and, 1-UL as shown.

A Nail parts together using two 3" (6.7cm) nails at each connection.

3A

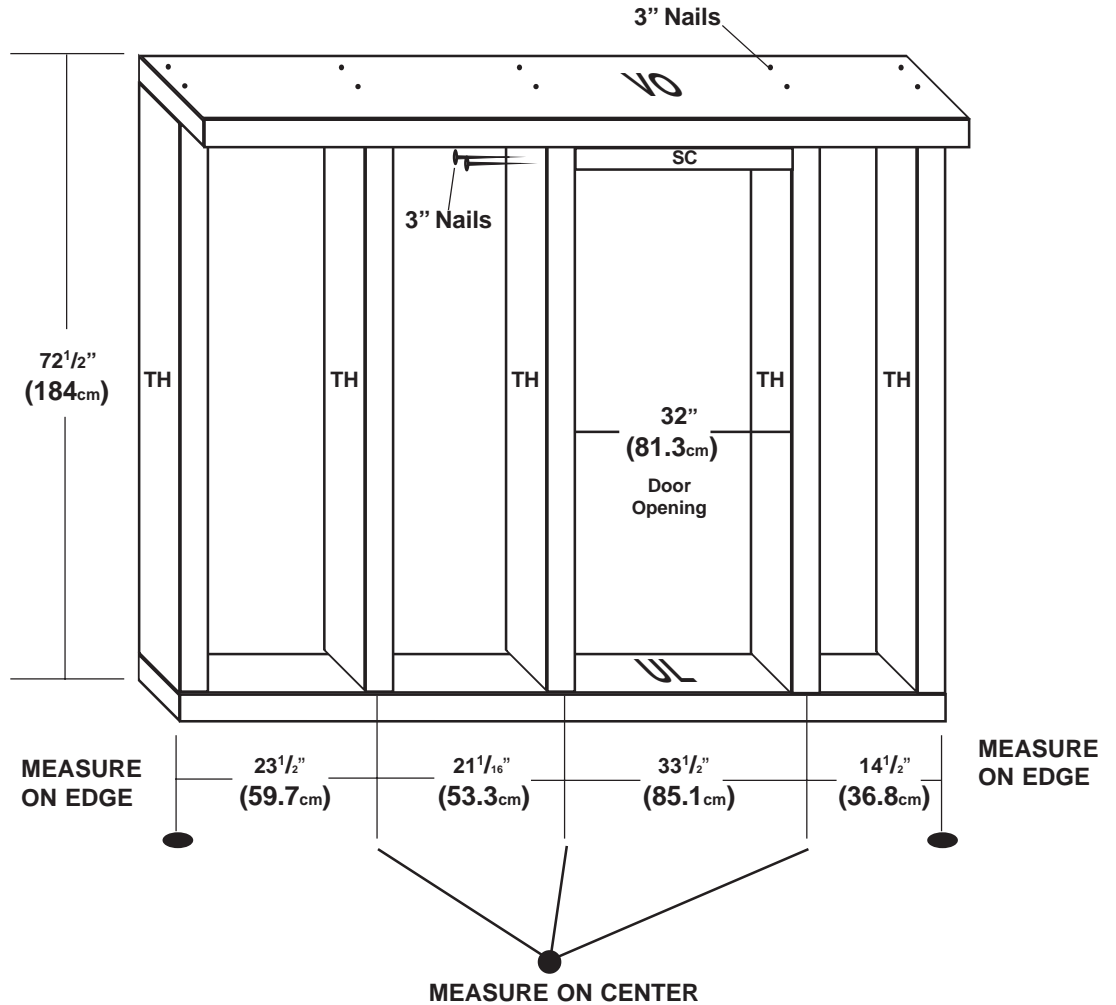

Tall Wall cont.

3B

3B. Install First Panel $14\frac{3}{8}'' \times 72''$ (36x183cm) as shown.

Nail, and follow sequence shown with four 2" (5cm) nails.

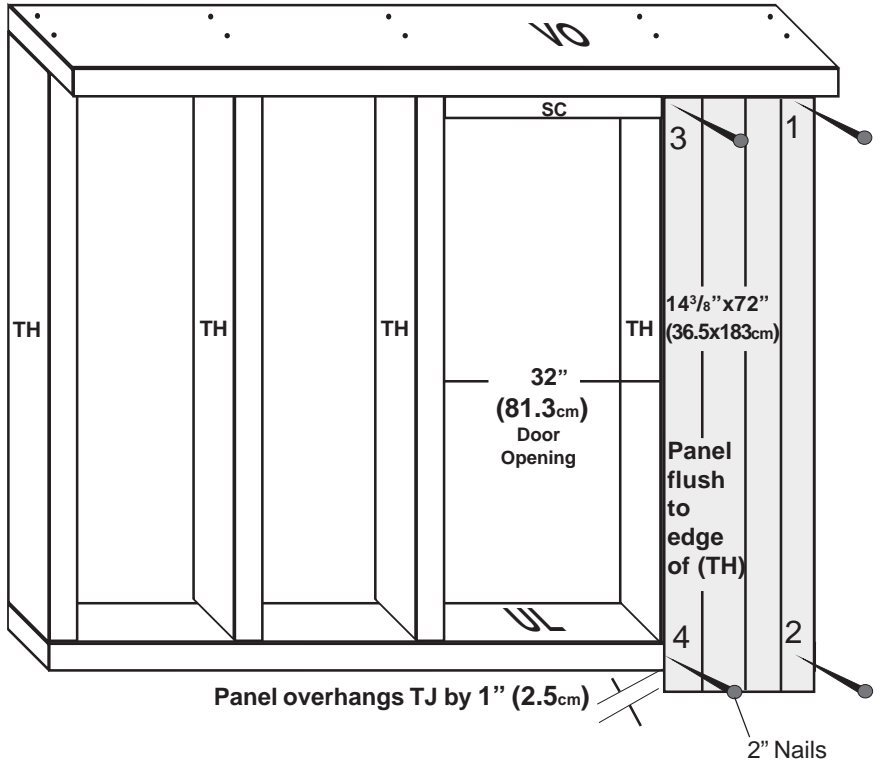

3C. Install Second Panel $44\frac{3}{8}'' \times 72''$ (112x183cm) as shown.

Nail, and follow sequence shown with four 2" (5cm) nails.

3C

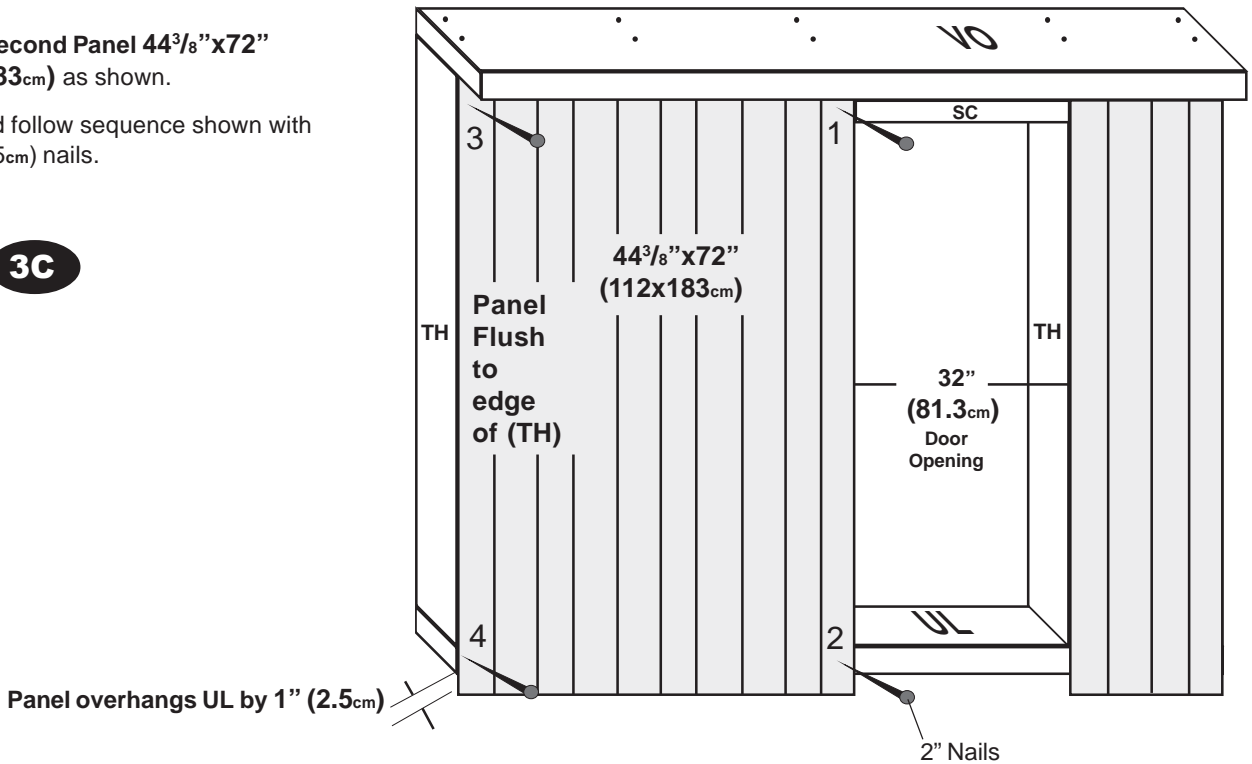

Tall Wall cont.

3D. Once all panels are in place secure to frame using 2" (5cm) nails spaced every 8" (20cm).

3D

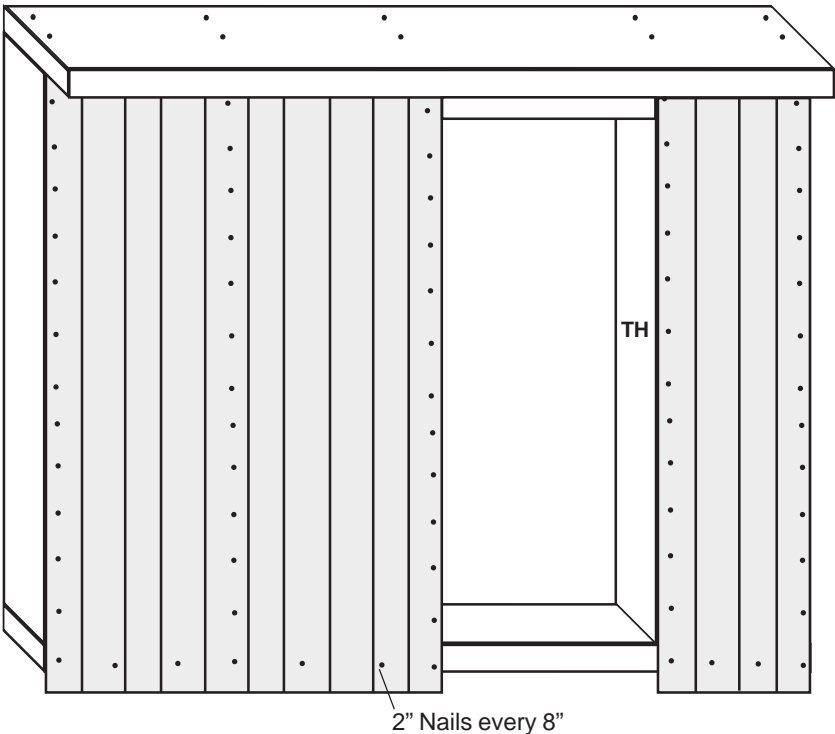

No Door

3 Extended Tall Wall Assembly

12' Long Wall

□ 1 VO		2 x 6 x 92 ⁵ / ₈ "	5 x 14 x 235cm
□ 1 VD		2 x 6 x 45 ¹ / ₂ "	5 x 14 x 115.5cm
□ 8 TH		2 x 4 x 69 ¹ / ₂ "	5 x 10 x 176cm
□ 1 UL		2 x 4 x 92 ⁵ / ₈ "	5 x 10 x 235cm
□ 1 SR		2 x 4 x 45 ¹ / ₂ "	5 x 10 x 115.5cm
□ 1 3B*	Wall Panel	45 ¹ / ₂ " x 72"	116 x 183cm
□ 1 3C*	Wall Panel	44 ³ / ₈ " x 72"	113 x 183cm
□ 1 3D*	Wall Panel	48" x 72"	122 x 183cm

* Refers To Step Panel is Used

3A. Arrange 1- VO, 1- VD, 8 - THs, 1- UL and, 1 - SR as shown.

3A

A Nail parts together using two 3" (6.7cm) nails at each connection.

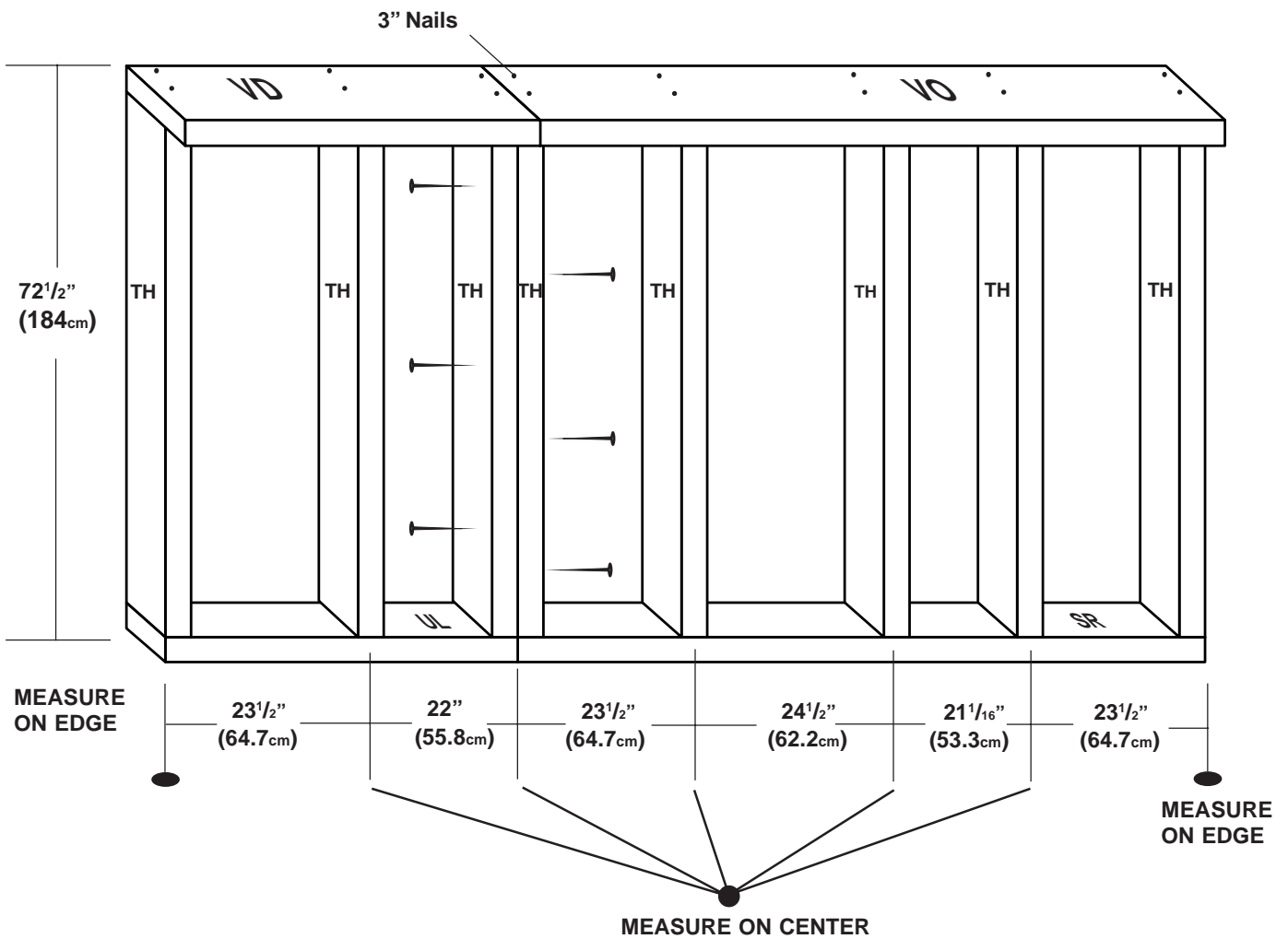

3B

3B. Install First Panel 44³/₈"x72"
(113x183cm) as shown.

Nail, and follow sequence shown with four 2" (5cm) nails.

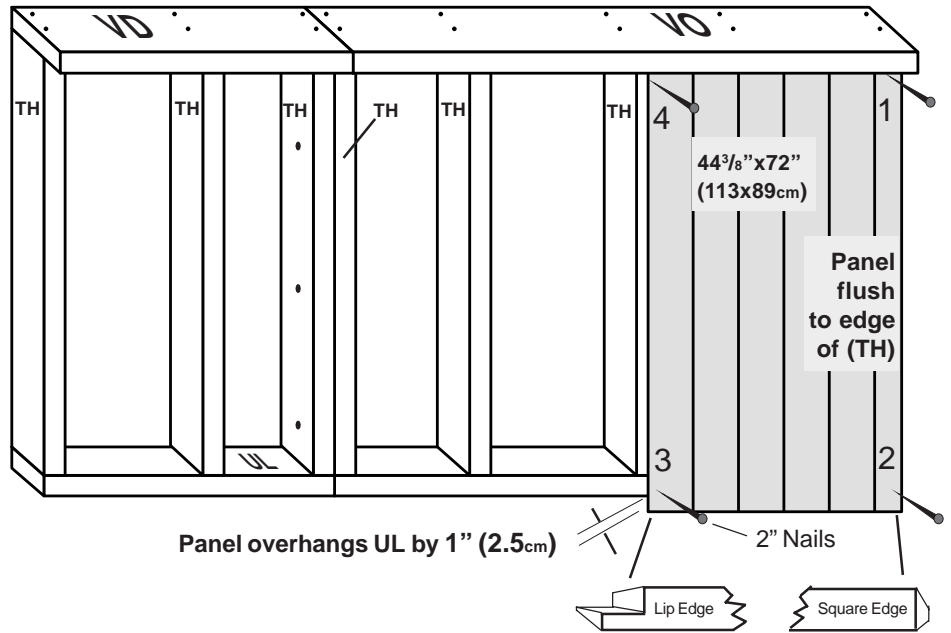

3C

3C. Install Second Panel 48"x72"
(122x183cm) as shown.

Nail, and follow sequence shown with four 2" (5cm) nails.

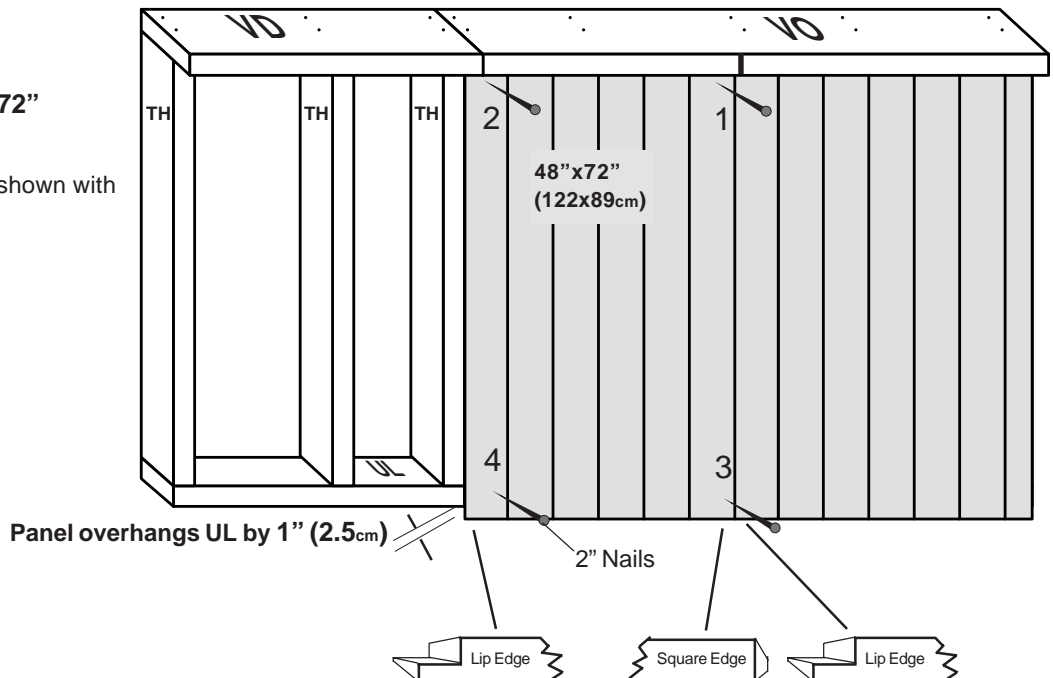

3D

3D. Install Third Panel 45 1/2" x 72" (116x183cm) as shown.

Nail, and follow sequence shown with four 2" (5cm) nails.

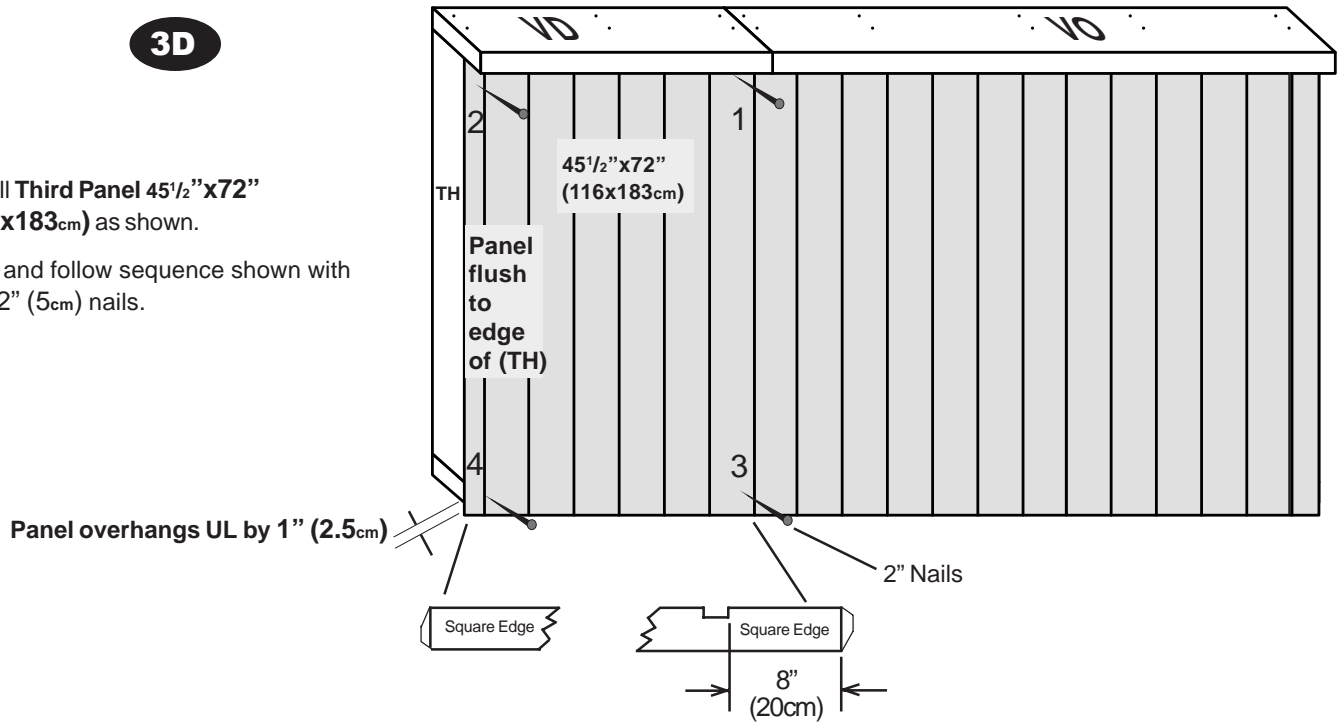

3E

3E. Once all panels are in place secure to frame using 2" (5cm) nails spaced every 8" (20cm).

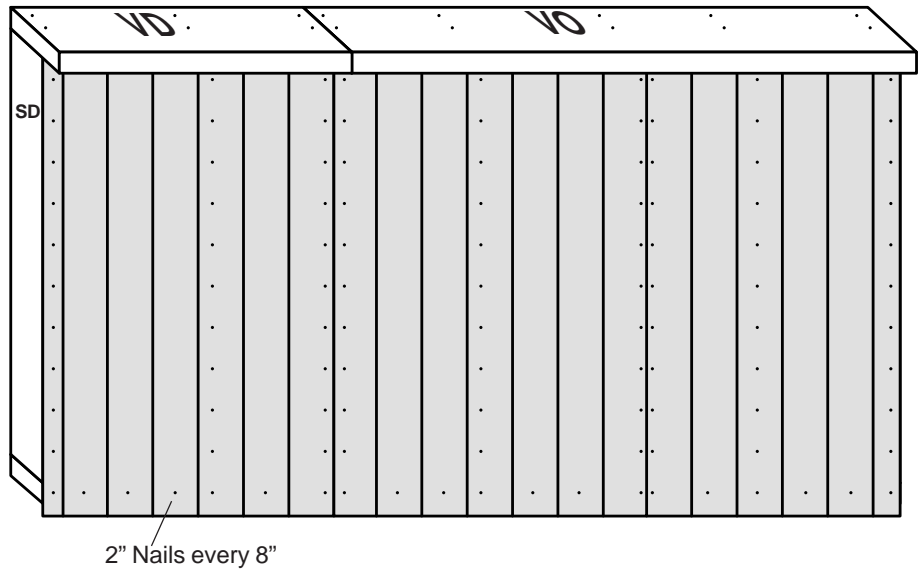

No Door

3 Extended Tall Wall

Assembly 16' Long Wall

□ 1 VO		2 x 6 x 92 ⁵ / ₈ "	5 x 14 x 235cm
□ 2 VD		2 x 6 x 45 ¹ / ₂ "	5 x 14 x 115.5cm
□ 11 TH		2 x 4 x 69 ¹ / ₂ "	5 x 10 x 176.5cm
□ 1 UL		2 x 4 x 92 ⁵ / ₈ "	5 x 10 x 235cm
□ 2 SR		2 x 4 x 45 ¹ / ₂ "	5 x 10 x 115.5cm
□ 1 3C*	Wall Panel	48" x 72"	122 x 183cm
□ 1 3C*	Wall Panel	44 ³ / ₈ " x 72"	113 x 183cm
□ 2 3B,D*	Wall Panel	45 ¹ / ₂ " x 72"	116 x 183cm

* Refers To Step Panel is Used

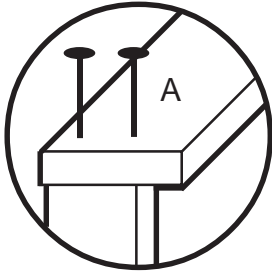

3A. Arrange 1- VO, 2 - VD, 11 - THs, 1- UL and, 1 - SR as shown.

A Nail parts together using two 3" (6.7cm) nails at each connection.

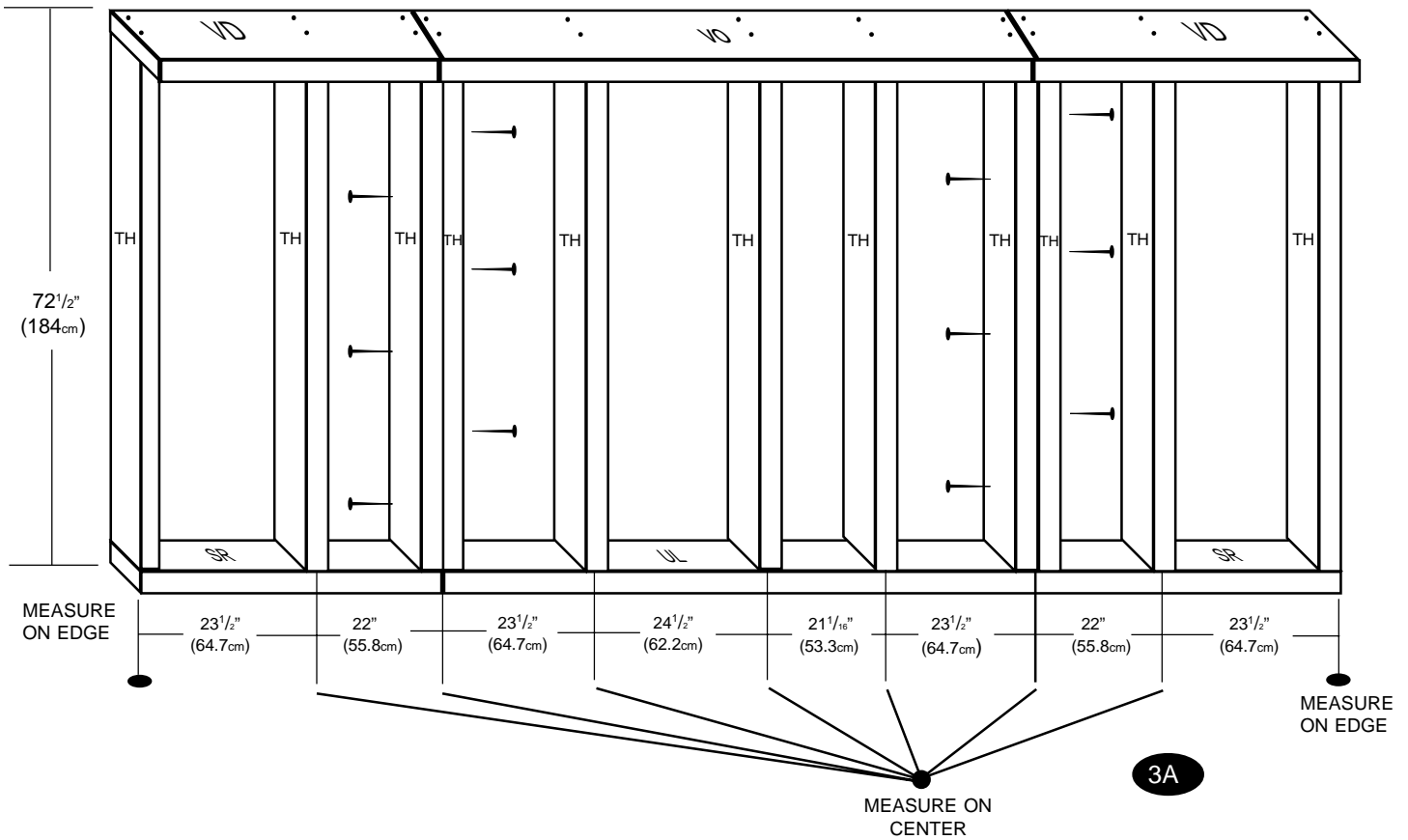

3B. Install First Panel 45 1/2" x 72" (116x183cm) as shown.

Nail, and follow sequence shown with four 2" (5cm) nails.

3B

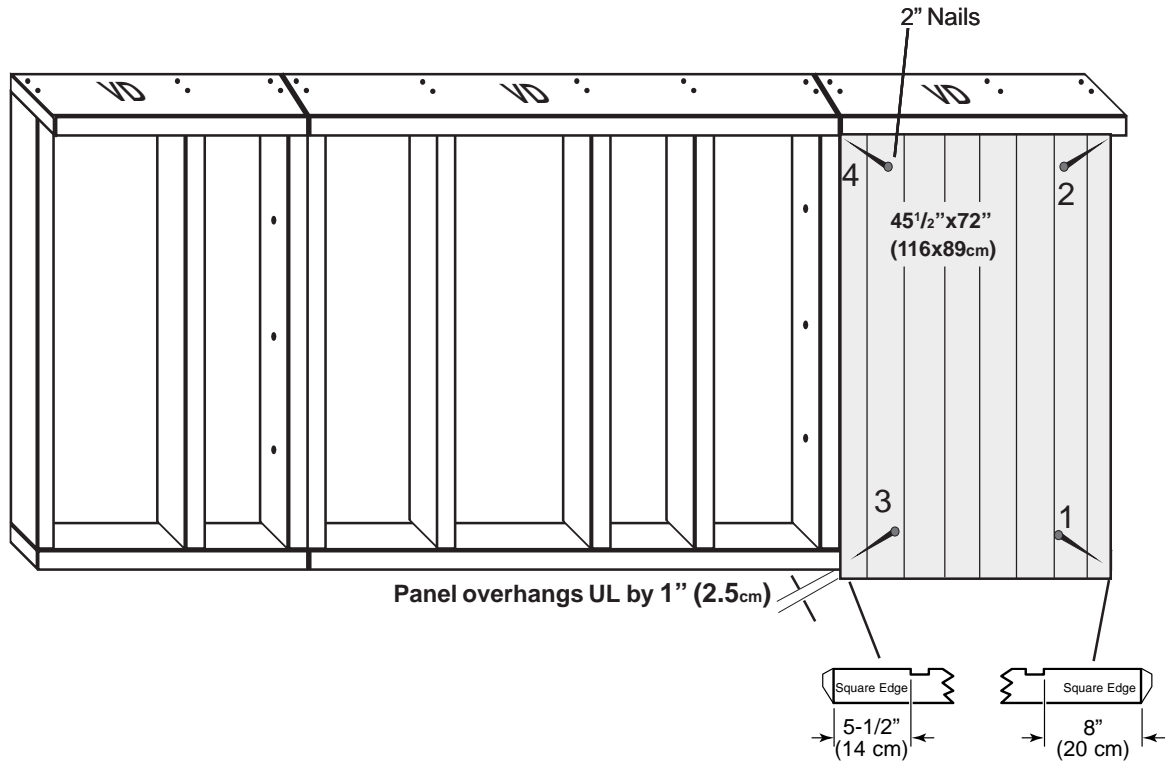

3C. Install Second Panel 44 3/8" x 72" (113x183cm) and Third Panel 48" x 72" (122x183cm) as shown.

Nail, and follow sequence shown with four 2" (5cm) nails.

3C

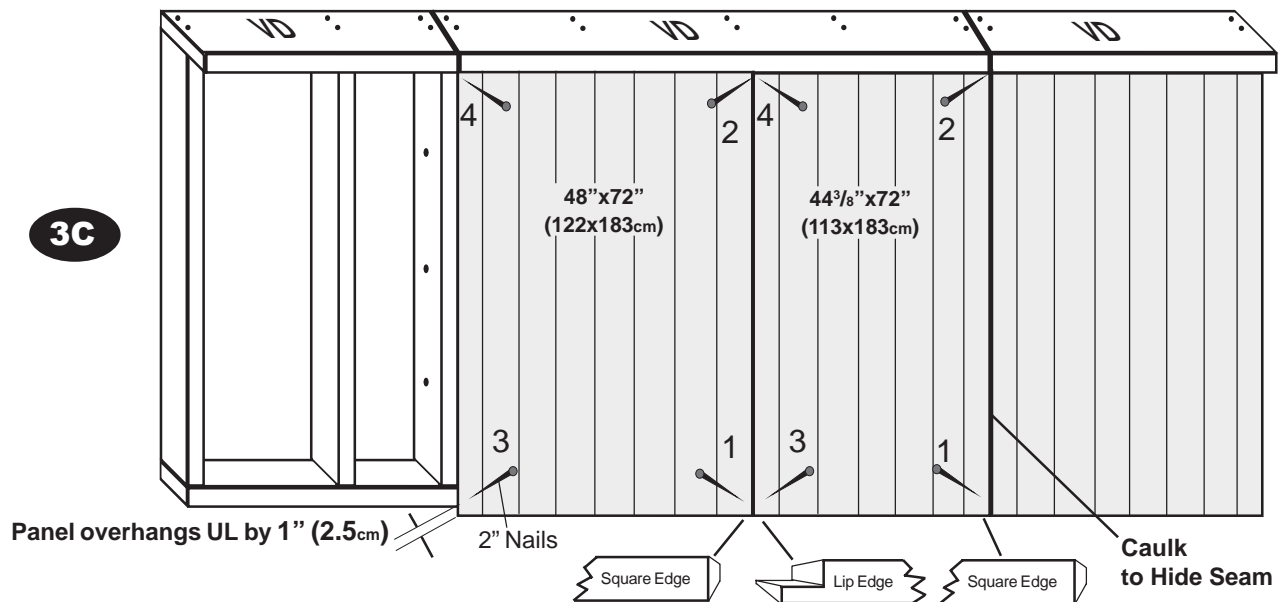

3D. Install Fourth Panel 45 1/2"x72" (116x183cm) as shown.

Nail, and follow sequence shown with four 2" (5cm) nails.

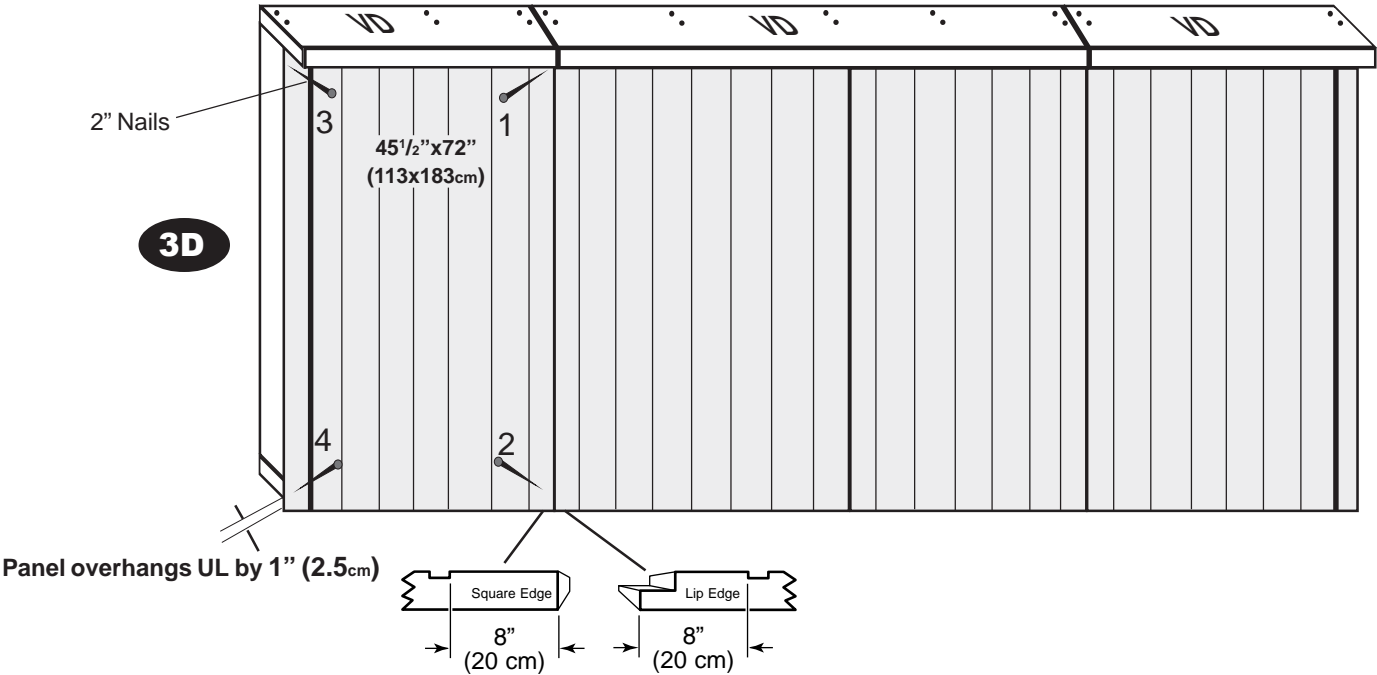

3E. Once all panels are in place secure to frame using 2" (5cm) nails spaced every 8" (20cm).

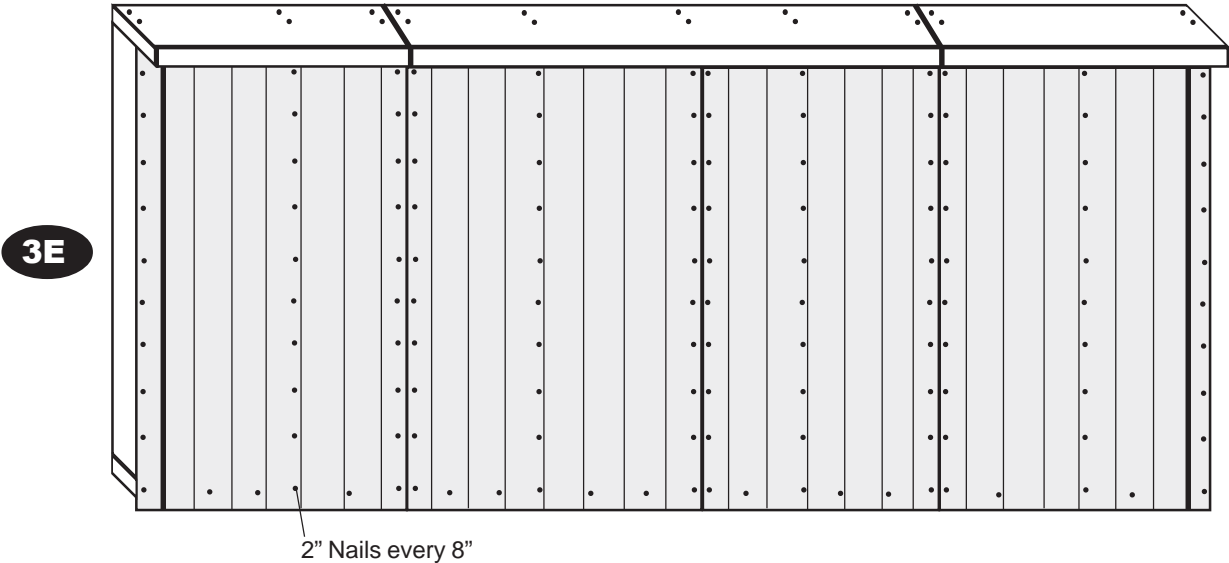

With Door

3 Extended Tall Wall Assembly

12' Long Wall

3A. Arrange 1- VO, 1-VD, 8- THs, 1- UL, 1- SC and, 1- SR as shown.

<input type="checkbox"/> 1 VO	2 x 6 x 92 ⁵ / ₈ "	5 x 14 x 235cm
<input type="checkbox"/> 1 VD	2 x 6 x 45 ¹ / ₂ "	5 x 14 x 115.5cm
<input type="checkbox"/> 8 TH	2 x 4 x 69 ¹ / ₂ "	5 x 10 x 176cm
<input type="checkbox"/> 1 UL	2 x 4 x 92 ⁵ / ₈ "	5 x 10 x 235cm
<input type="checkbox"/> 1 SR	2 x 4 x 45 ¹ / ₂ "	5 x 10 x 115.5cm
<input type="checkbox"/> 1 3B*	Wall Panel 45 ¹ / ₂ " x 72"	116 x 183cm
<input type="checkbox"/> 1 3C*	Wall Panel 44 ³ / ₈ " x 72"	113 x 183cm
<input type="checkbox"/> 1 3D*	Wall Panel 14 ³ / ₈ " x 72"	36 x 183cm
<input type="checkbox"/> 1 SC	2 x 4 x 32"	5 x 10 x 81.3cm

* Refers To Step Panel is Used

A Nail parts together using two 3" (6.7cm) nails at each connection.

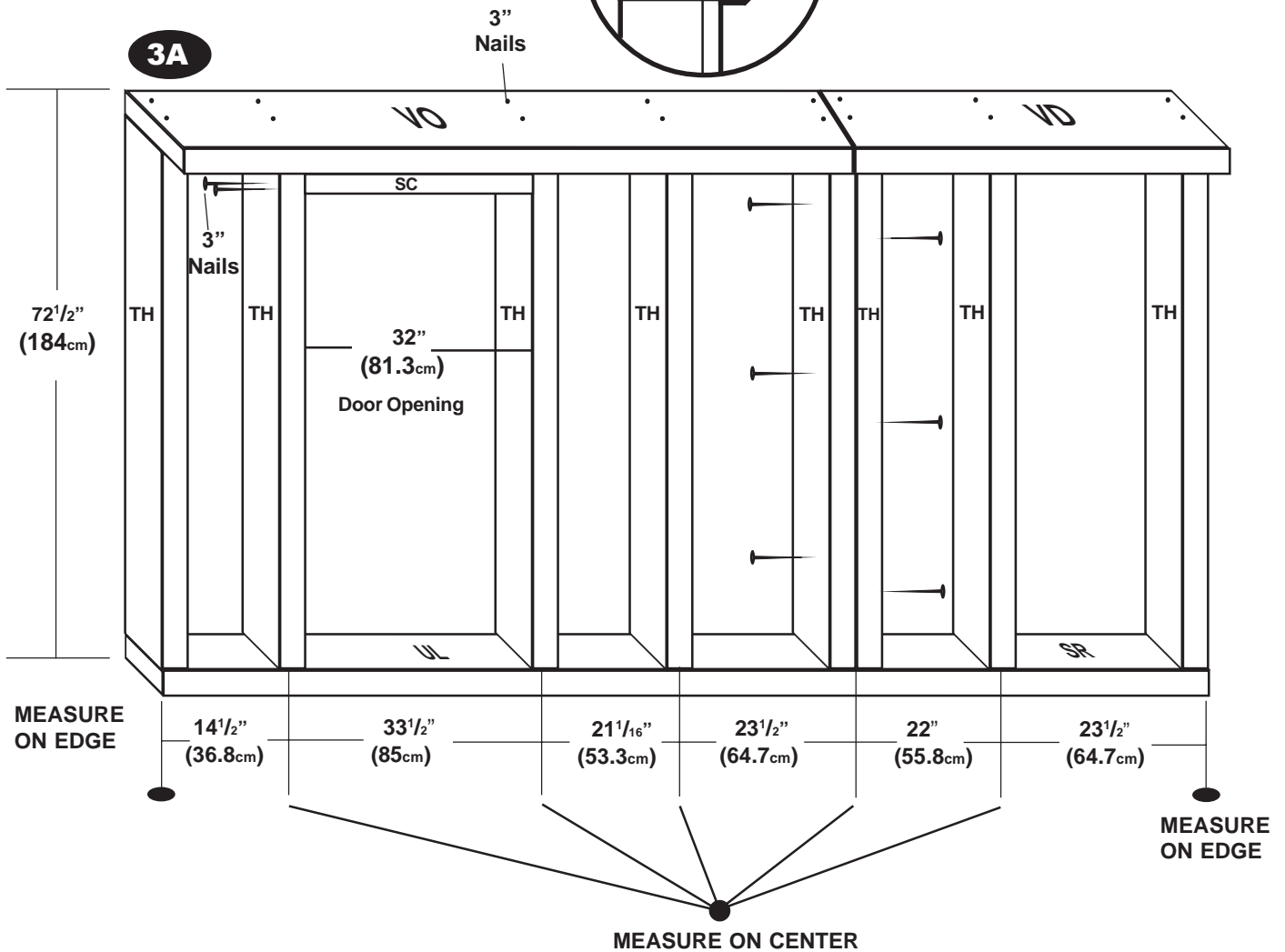
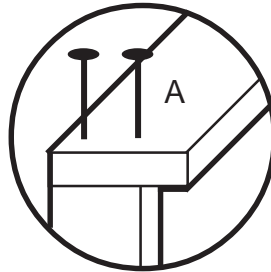

Extended Tail Wall Assembly

cont.

3B

3B. Install First Panel $45\frac{1}{2}'' \times 72''$ (116x183cm) as shown.

Nail, and follow sequence shown with four 2'' (5cm) nails.

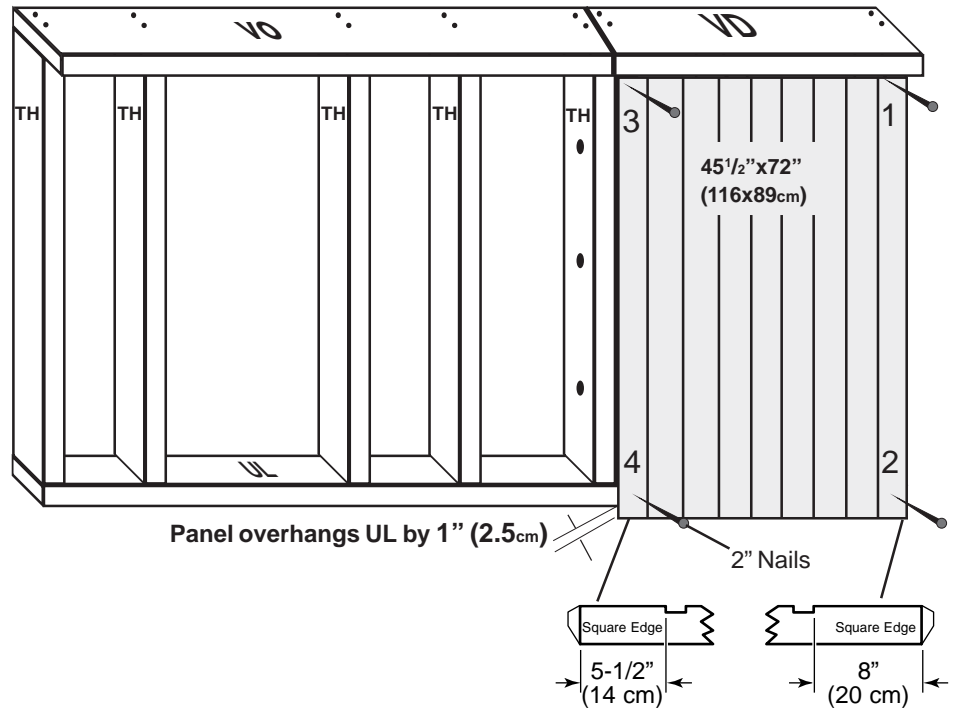

3C

3C. Install Second Panel $44\frac{3}{8}'' \times 72''$ (113x183cm) as shown.

Nail, and follow sequence shown with four 2'' (5cm) nails.

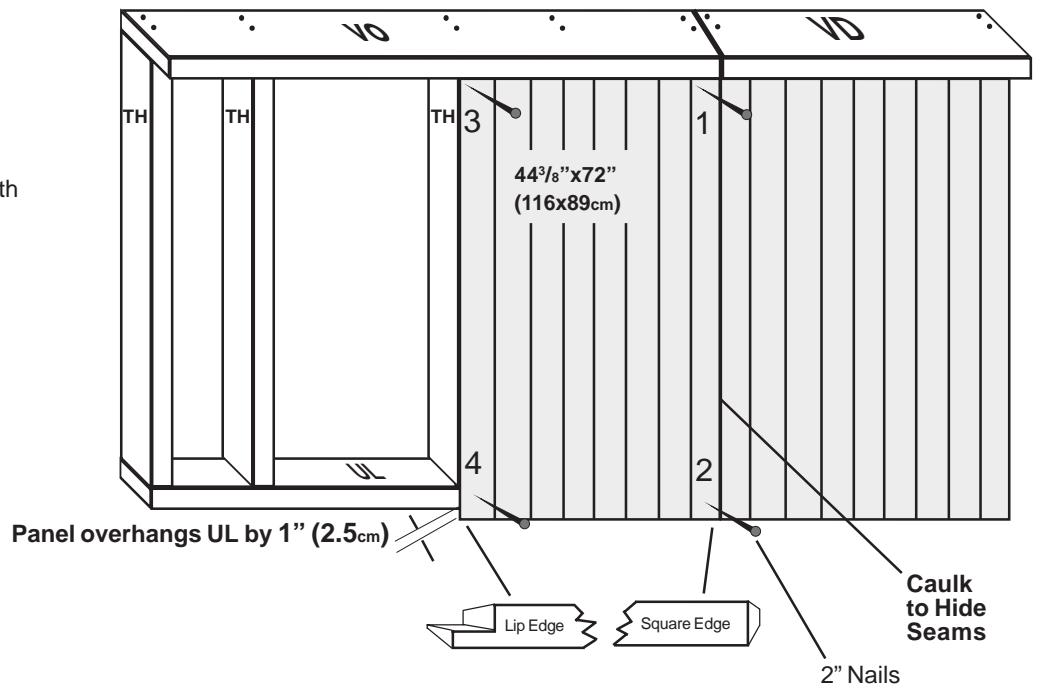

3D

3D. Install Third Panel 14³/₈"x72"
(36x183cm) as shown.

Nail, and follow sequence shown with
four 2" (5cm) nails.

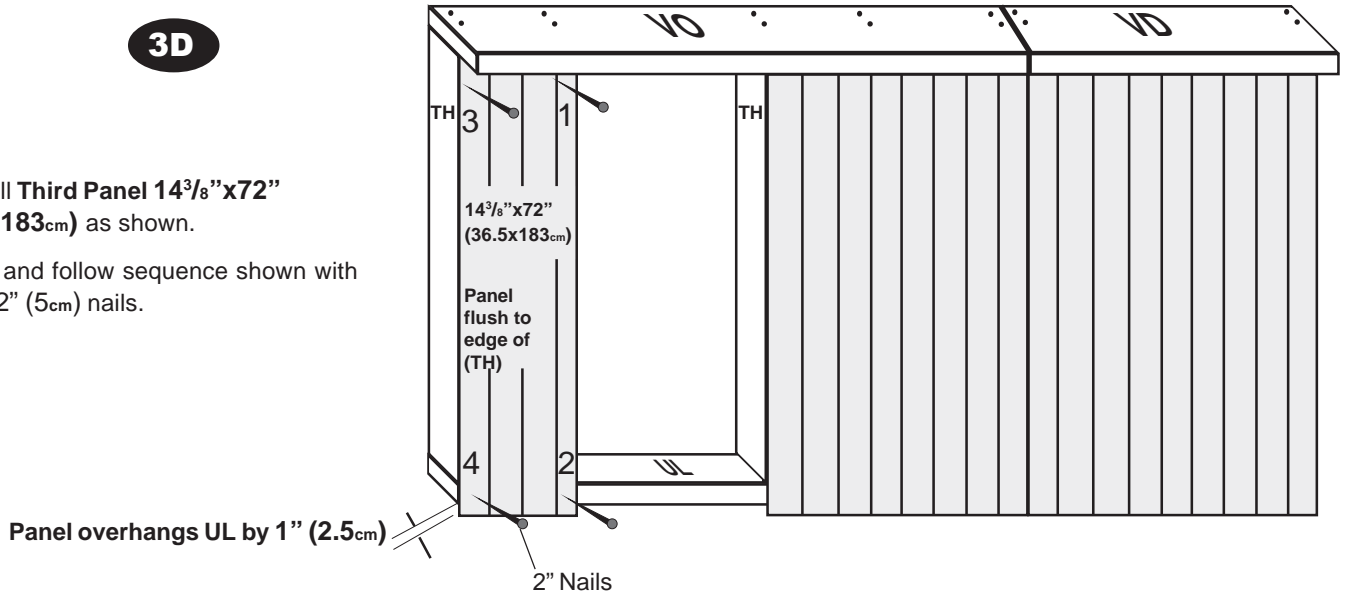

3E

3E. Once all panels are in place
secure to frame using 2" (5cm)
nails spaced every 8" (20cm).

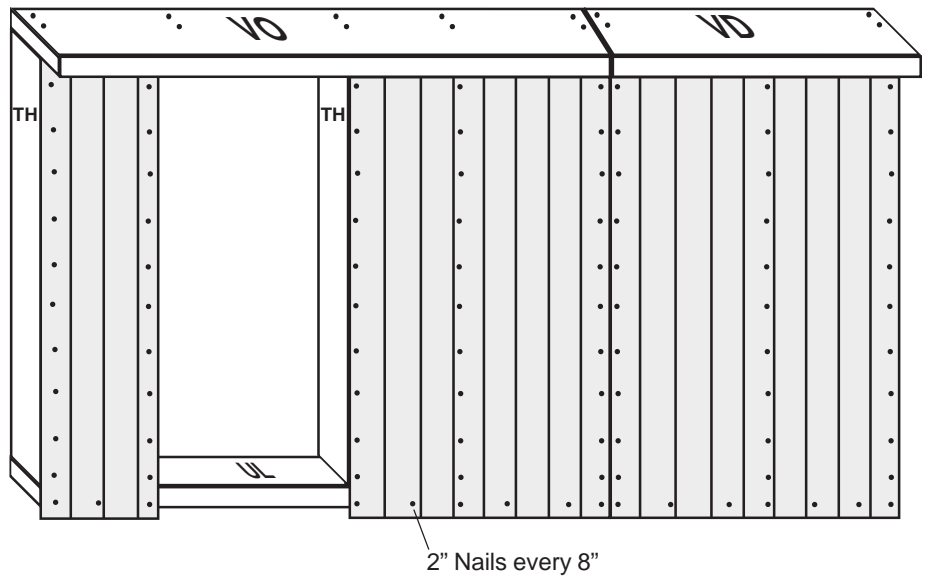

3 Extended Tall Wall Assembly with Door

16' Long Wall

□ 1 VO		2 x 6 x 92 ⁵ / ₈ "	5 x 14 x 235cm
□ 2 VD		2 x 6 x 45 ¹ / ₂ "	5 x 14 x 115.5cm
□ 11 TH		2 x 4 x 69 ¹ / ₂ "	5 x 10 x 176.5cm
□ 1 UL		2 x 4 x 92 ⁵ / ₈ "	5 x 10 x 235cm
□ 2 SR		2 x 4 x 45 ¹ / ₂ "	5 x 10 x 115.5cm
□ 1 3C*	Wall Panel	14 ³ / ₈ " x 72"	36 x 183cm
□ 1 3C*	Wall Panel	44 ³ / ₈ " x 72"	113 x 183cm
□ 2 3B,D*	Wall Panel	45 ¹ / ₂ " x 72"	116 x 183cm
□ 1 SC		2 x 4 x 32"	5 x 10 x 81.3cm

* Refers To Step Panel is Used

3A. Arrange 1- VO, 2- VD, 11- THs, 1- UL, 1- SC and 2- SR as shown.

A Nail parts together using two 3" (6.7cm) nails at each connection.

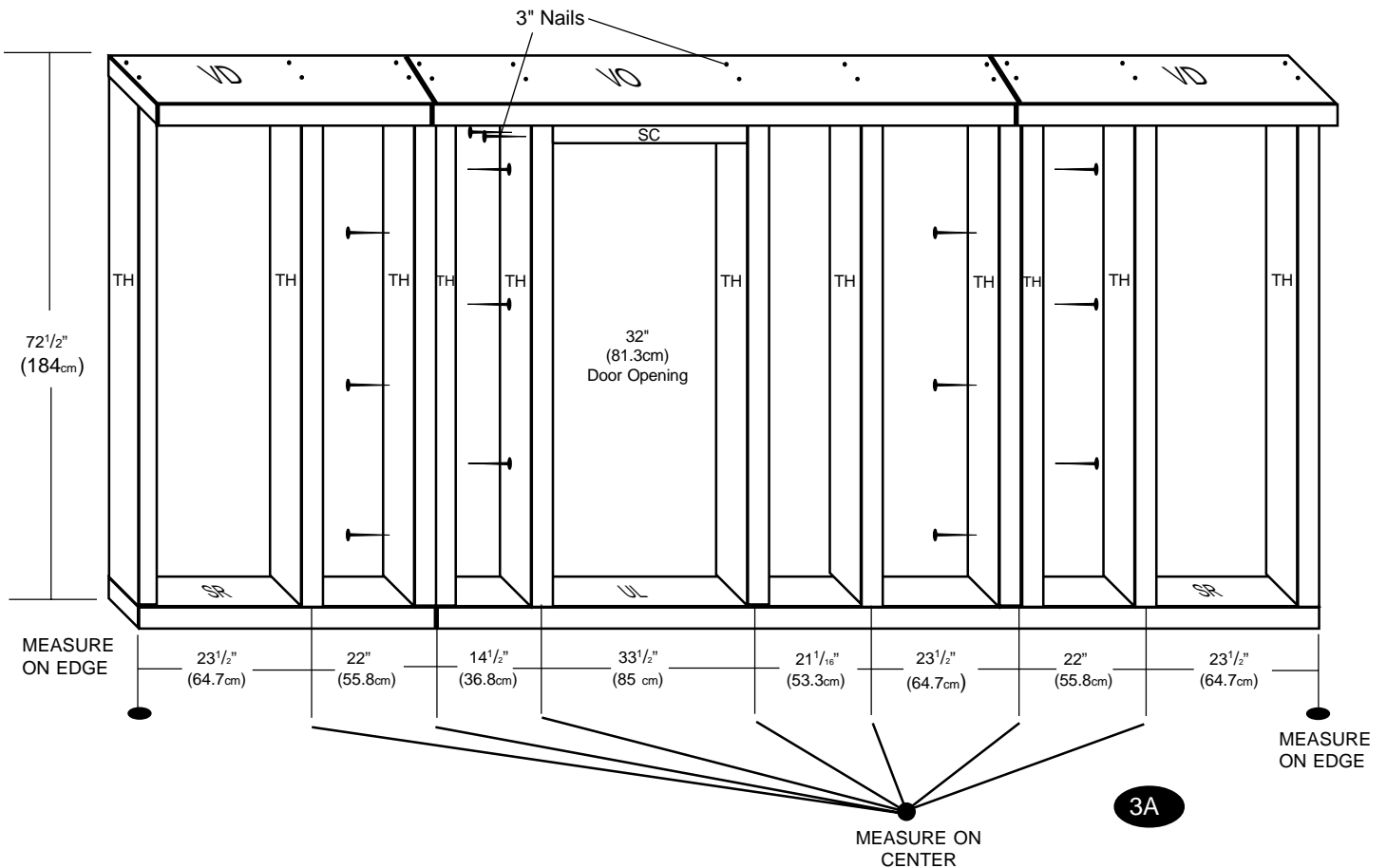
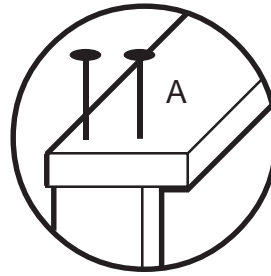

3B. Install First Panel 45¹/₂"x72"
(116x183cm) as shown.

Nail, and follow sequence shown with
 four 2" (5cm) nails.

3B

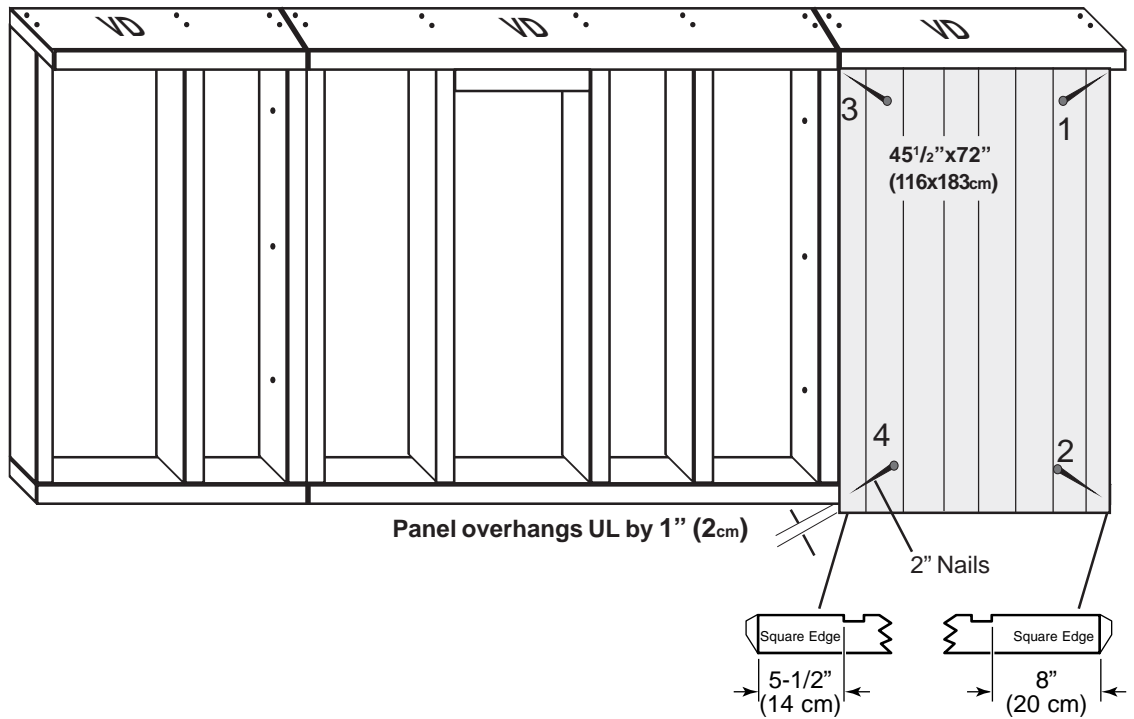

3C. Install Second Panel 44³/₈"x72"
(113x183cm) and **Third Panel 14³/₈" x 72"**
(36x183cm) as shown.

Nail, and follow sequence shown with
 four 2" (5cm) nails.

3C

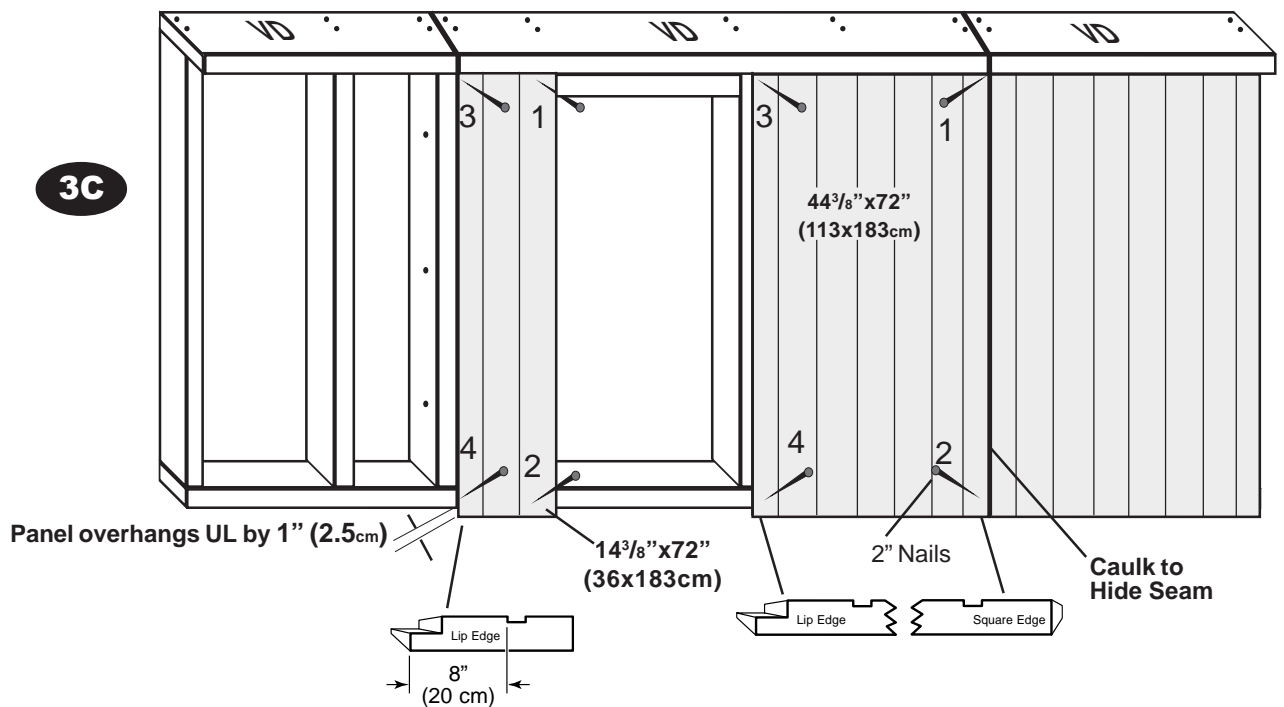

Extended Tall Wall

Cont.

3B. Install Fourth Panel $45\frac{1}{2}'' \times 72''$ ($116 \times 183\text{cm}$) as shown.

Nail, and follow sequence shown with four 2'' (5cm) nails.

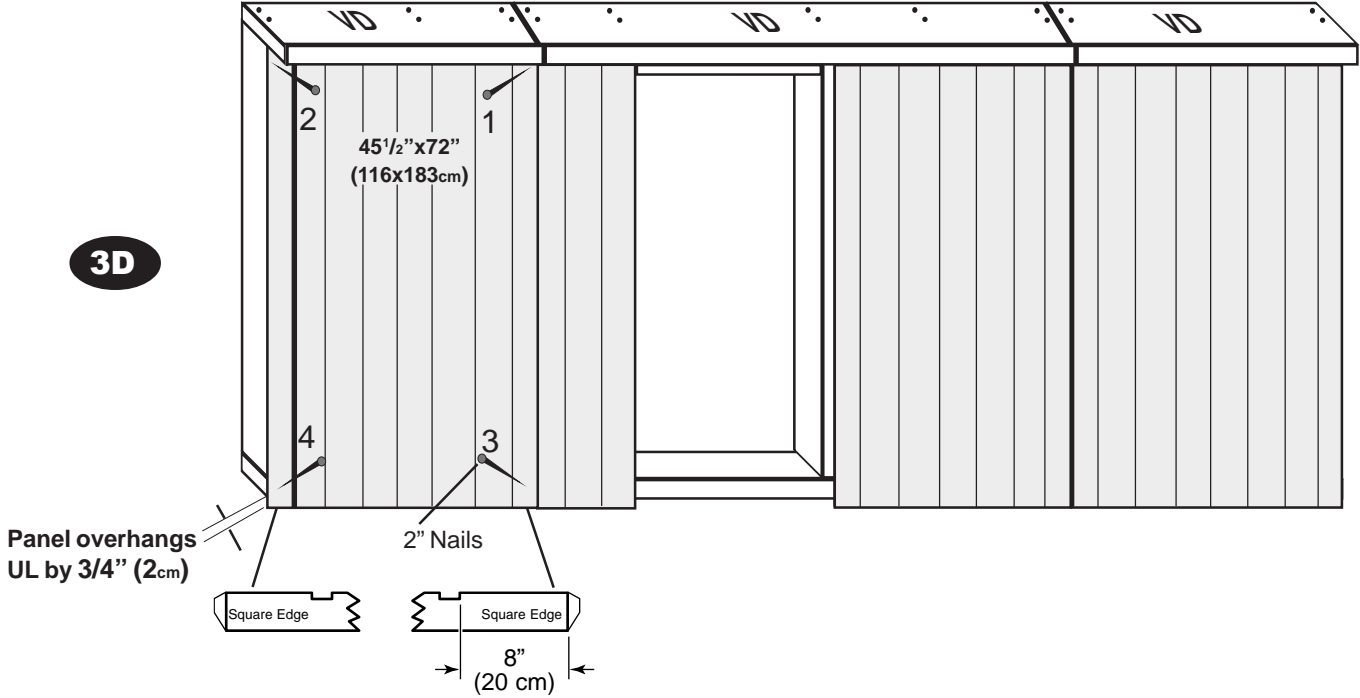

3E. Once all panels are in place secure to frame using 2'' (5cm) nails spaced every 8'' (20cm).

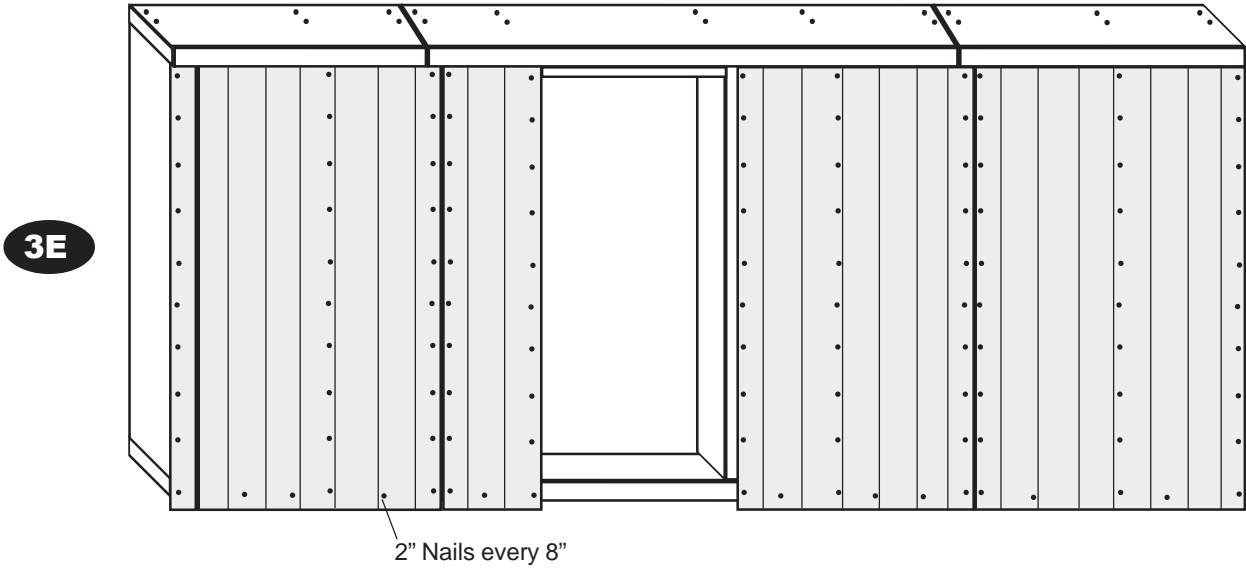

4 Erecting Walls All Sizes

<input type="checkbox"/> 2	Assembled Side Walls
<input type="checkbox"/> 1	Assembled Tall Wall
<input type="checkbox"/> 1	Assembled Short Wall

4A. Stand **Tall Wall** as shown.

A Nail $3/4"$ (2cm) overhang to floor using $2"$ (5cm) nails spaced $12"$ (30cm) apart.

B Nail frame to floor using $3"$ (7.6cm) nails as shown.

C Making sure wall is vertically level, temporarily secure HJ for support as shown.

4A

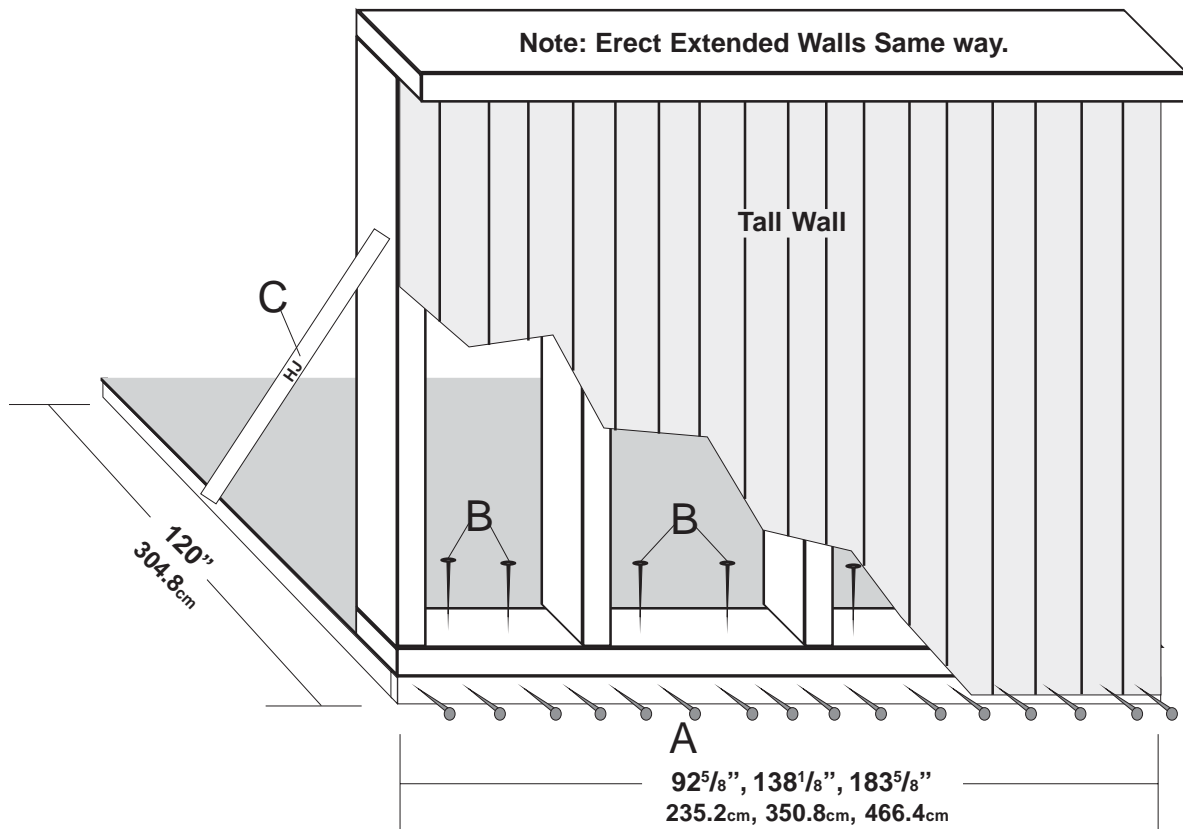

4B. Position Right Side Wall Assembly as Shown.

A Secure Side Wall to Tall Wall using 2" (5cm) Nails.

B Nail 3/4" (2cm) overhang to floor using 2" (5cm) nails spaced 12" (30cm) apart.

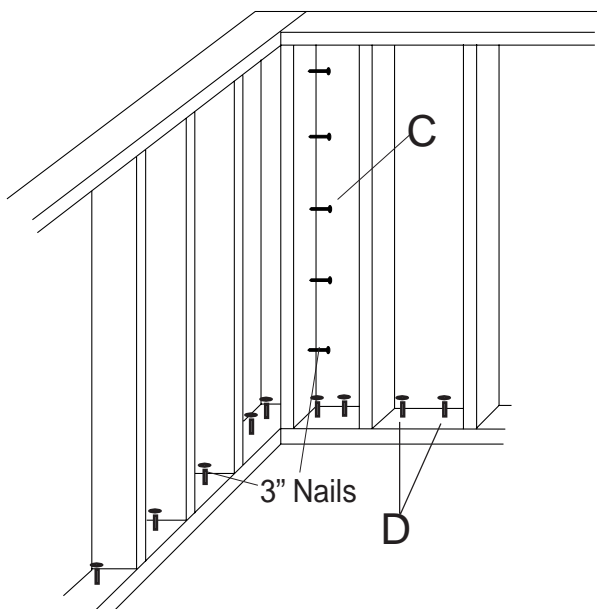
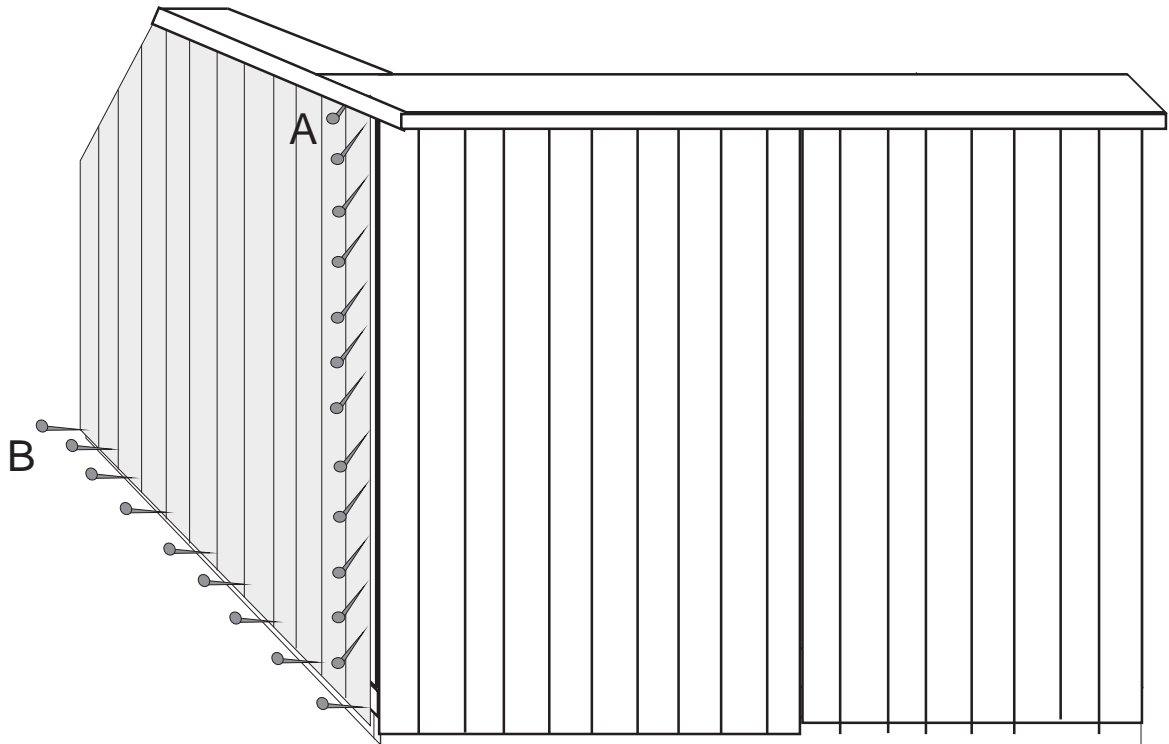

C Secure inside walls together using 3" (7.6cm) nails.

D Nail frame to floor using 3" (7.6cm) nails as shown.

Repeat these steps for the remaining side and back wall panels

5 Assembling Trusses All size Buildings

RIGHT TRUSS Parts List				
□ 1	TF	Rafter	2 x 4 x 64 ⁷ / ₈ "	5 x 10 x 165cm
□ 1	RO	Rafter	2 x 4 x 93 ¹³ / ₁₆ "	5 x 10 x 238cm
□ 1	--	Gusset	----	----

5A. Lay out parts for **ONE RIGHT TRUSS** as shown: one TF and one RO. Use gusset as a guide.

HINT: Ensure 129-15/16" dimension.

5B. Assemble right truss using fourteen 2" (5cm) nails in gusset.

Note: Glue may be used in addition to nails for added strength (glue not supplied with kit).

IMPORTANT! ASSEMBLE ONE RIGHT TRUSS ASSEMBLY

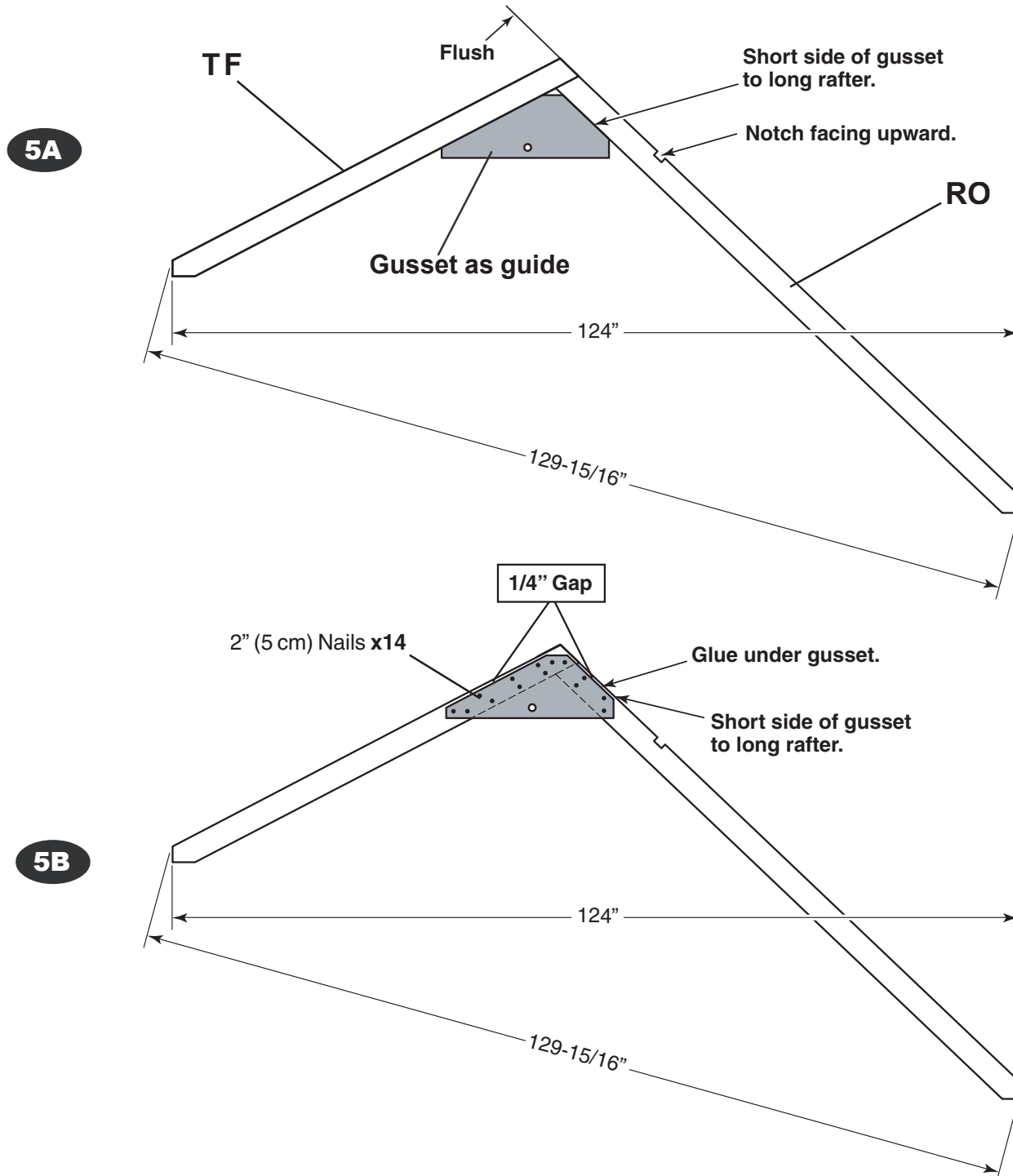

5 Assembling Trusses All size Buildings

LEFT TRUSS Parts List				
□ 1	TF	Rafter	2 x 4 x 64 ⁷ / ₈ "	5 x 10 x 165cm
□ 1	RO	Rafter	2 x 4 x 93 ¹³ / ₁₆ "	5 x 10 x 238cm
□ 1	--	Gusset	---	---

5C. Lay out parts for **ONE LEFT TRUSS** as shown: one TF and one RO. Use gusset as a guide.

HINT: Ensure 129-15/16" dimension.

5D. Assemble left truss using fourteen 2" (5cm) nails in gusset.

Note: Glue may be used in addition to nails for added strength (glue not supplied with kit).

IMPORTANT! ASSEMBLE ONE LEFT TRUSS ASSEMBLY

5C

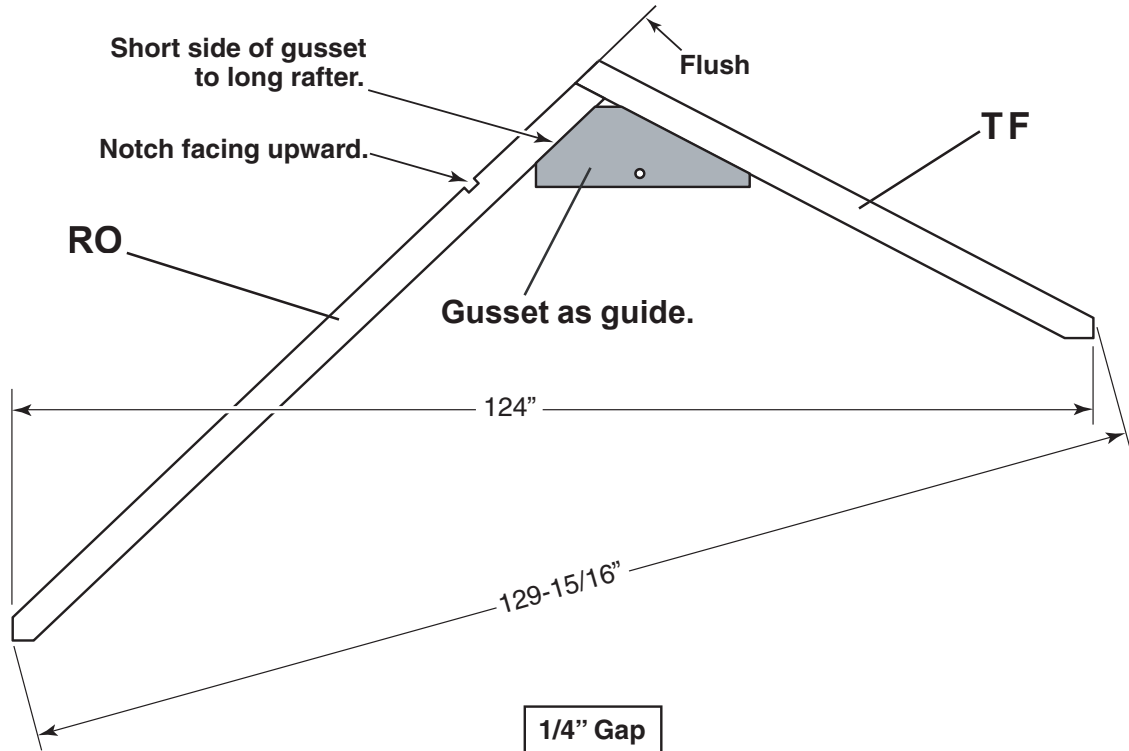

5D

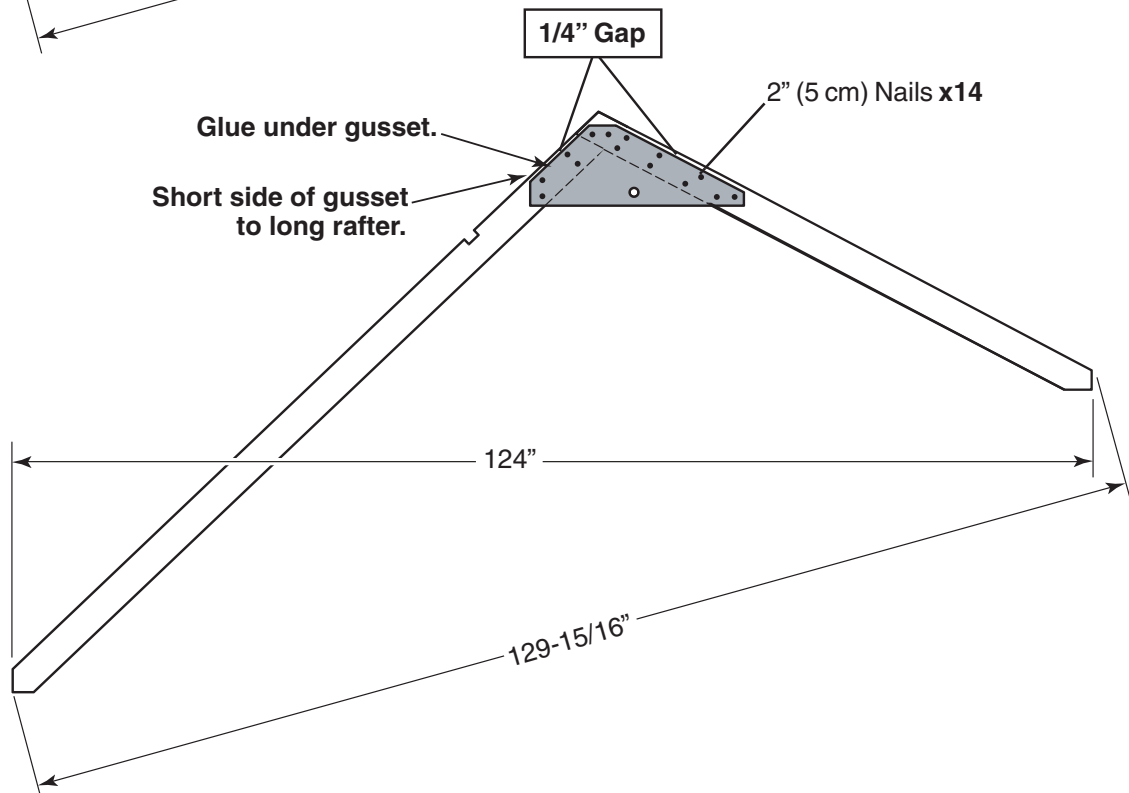

5 Assembling Trusses All size Buildings

CENTER TRUSS Parts List				
□ 1	TF	Rafter	2 x 4 x 64 ⁷ / ₈ "	5 x 10 x 165cm
□ 1	RO	Rafter	2 x 4 x 93 ¹³ / ₁₆ "	5 x 10 x 238cm
□ 2	--	Gussets	----	----

5E. Lay out parts for center truss as shown: one **TF** and one **RO**. Use gusset as a guide. **Hint:** Ensure 129-15/16" dimension.

5F. Assemble center truss using fourteen 2" (5cm) nails in gusset.

5G. Carefully flip truss over and finish assembling using fourteen 2" (5cm) nails in gusset.

Note: Glue may be used in addition to nails for added strength (glue not supplied with kit).

5H. Refer to chart on next page to determine the number of double gusset trusses to assemble.

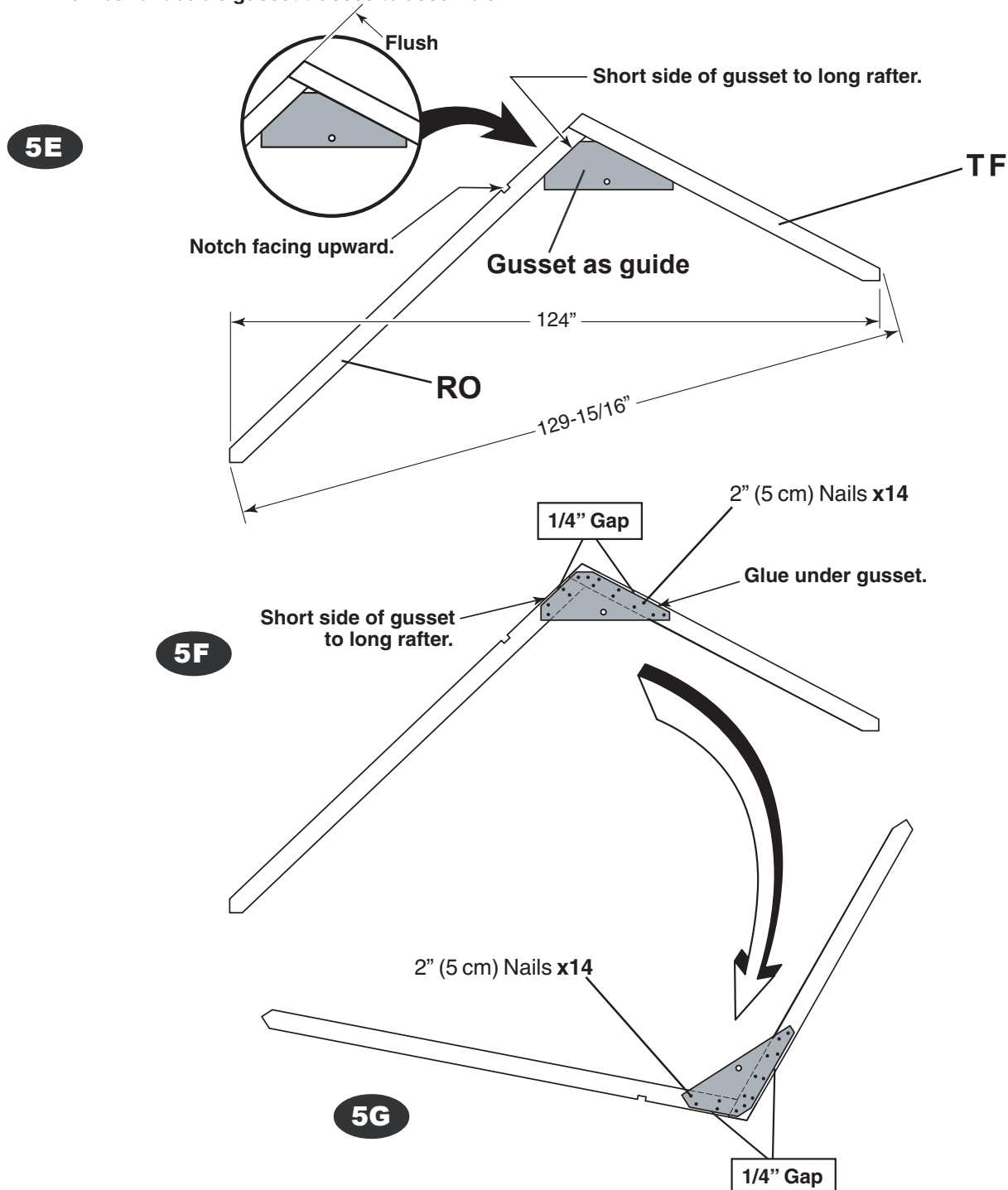

5 Assembling Trusses All size Buildings

10x8 Parts List				
□ 5	TF	Rafter	2 x 4 x 64 ⁷ / ₈ "	5 x 10 x 165cm
□ 5	RO	Rafter	2 x 4 x 93 ¹³ / ₁₆ "	5 x 10 x 238cm
□ 8	--	Gussets	----	----

10x12 Parts List				
□ 7	TF	Rafter	2 x 4 x 64 ⁷ / ₈ "	5 x 10 x 165cm
□ 7	RO	Rafter	2 x 4 x 93 ¹³ / ₁₆ "	5 x 10 x 238cm
□ 12	--	Gussets	----	----

10x16 Parts List				
□ 9	TF	Rafter	2 x 4 x 64 ⁷ / ₈ "	5 x 10 x 165cm
□ 9	RO	Rafter	2 x 4 x 93 ¹³ / ₁₆ "	5 x 10 x 238cm
□ 16	--	Gussets	----	----

5H

Truss Assembly Chart

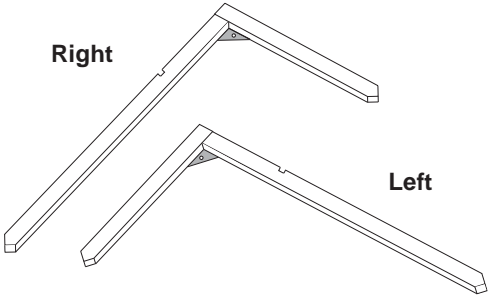
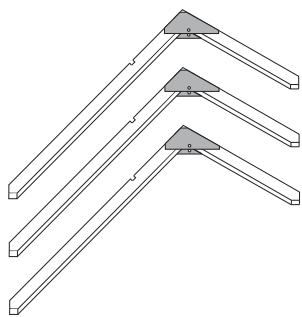
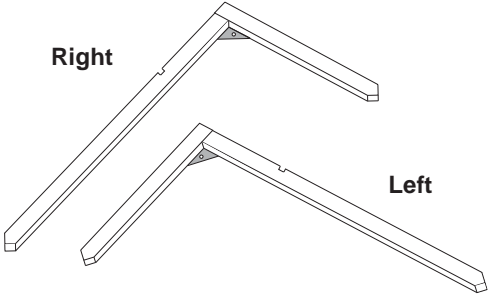
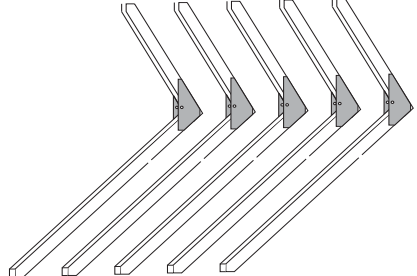
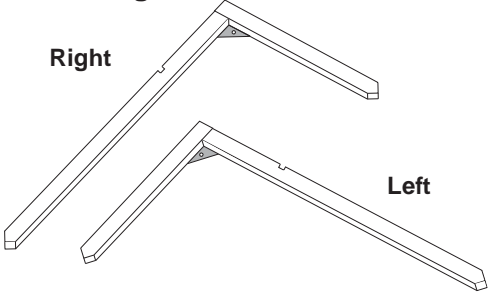
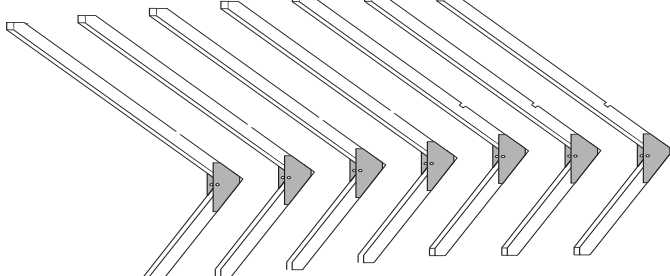
10 x 8 Building	
<p>2 Single Gusset Trusses</p> 	<p>3 Double Gusset Trusses</p> 
10 x 12 Building	
<p>2 Single Gusset Trusses</p> 	<p>5 Double Gusset Trusses</p> 
10 x 16 Building	
<p>2 Single Gusset Trusses</p> 	<p>7 Double Gusset Trusses</p> 

6 Erect Trusses All size Buildings

10x8 Parts List		
□ 3	--	Two Gusset Trusses
□ 2	--	One Gusset Trusses
□ 8	IE	1 x 4 x 21 ¹ / ₄ " 2 x 9 x 54cm

10x12 Parts List		
□ 5	--	Two Gusset Trusses
□ 2	--	One Gusset Trusses
□ 12	IE	1 x 4 x 21 ¹ / ₄ " 2 x 9 x 54cm

10x16 Parts List		
□ 7	--	Two Gusset Trusses
□ 2	--	One Gusset Trusses
□ 16	IE	1 x 4 x 21 ¹ / ₄ " 2 x 9 x 54cm

6A. Erect trusses as shown by using the IEs as spacers between trusses on both the tall and short wall.

A Make sure the single gusset trusses are located next to side walls with the gussets to the inside.

B Secure trusses to VO using two 3" (7.6cm) Screws.

C Secure IEs to VO using three 2" (5cm) nails.

6B. Secure Trusses to Tall Wall in same manner.

Note: If your building requires more than 5-trusses (i.e. 10 x 12 & 10 x 16) continue placing trusses in the same manner.

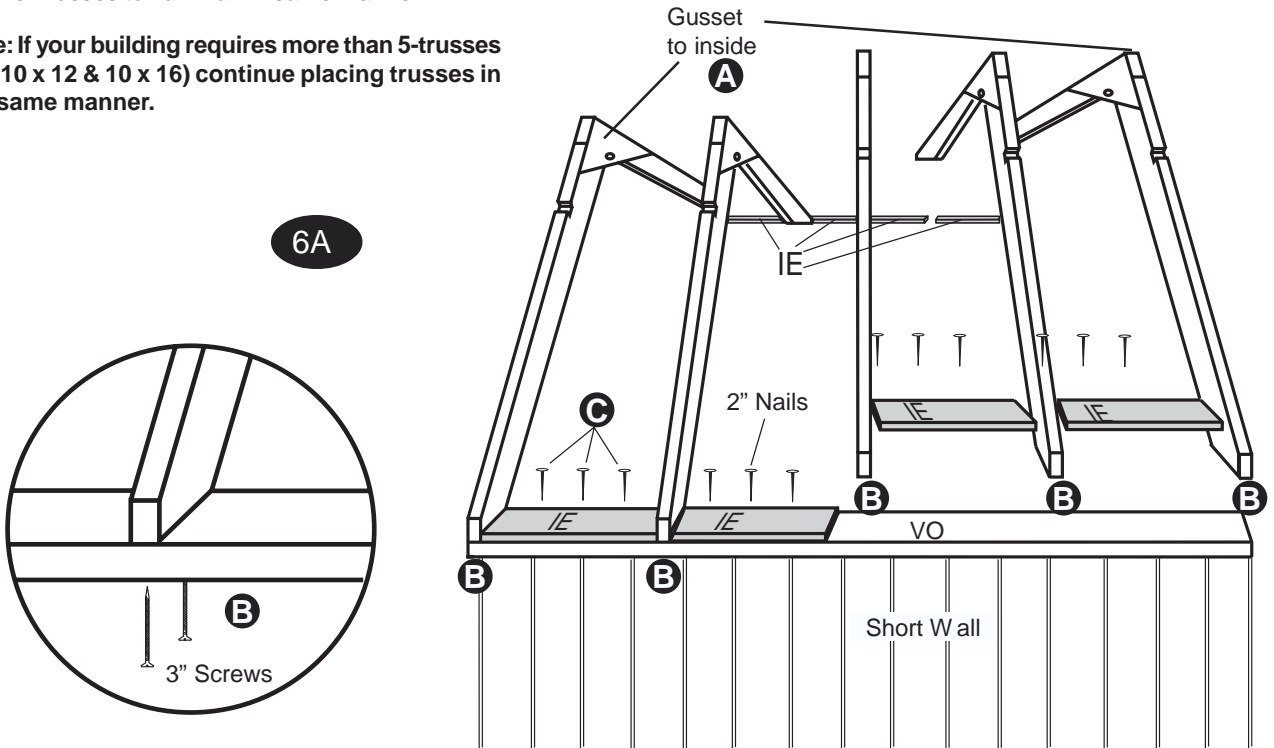

6A

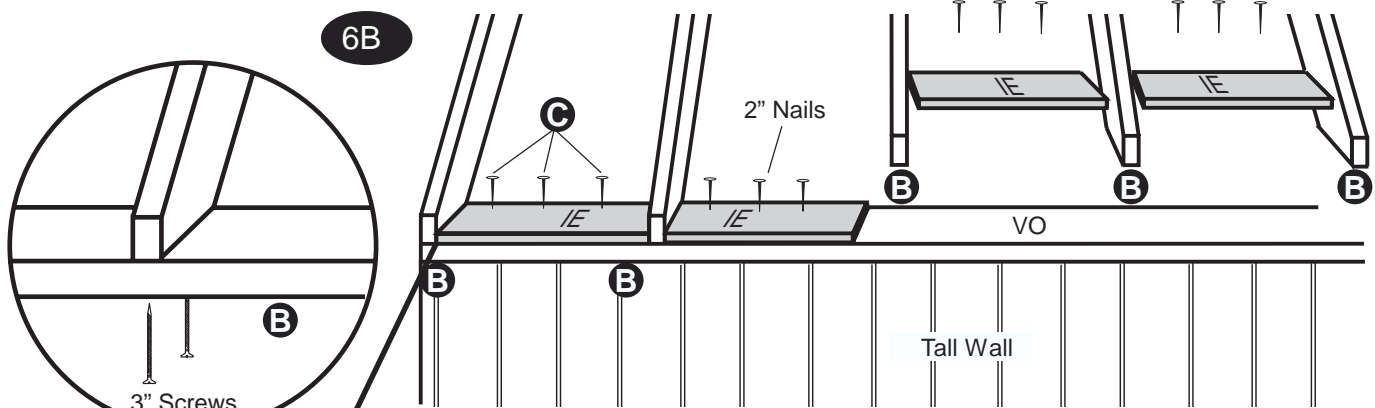
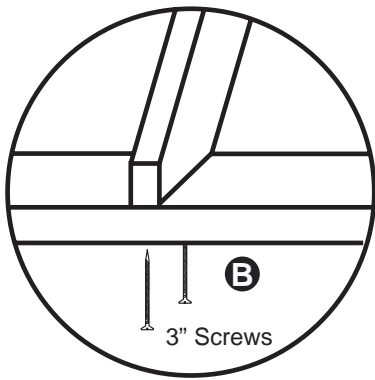

6B

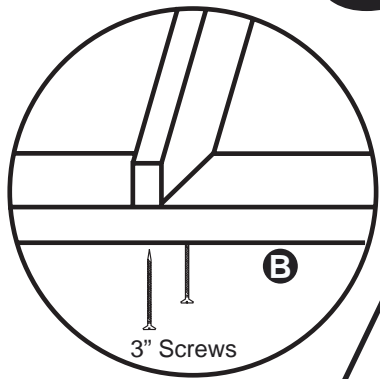

Flush to Outside

6 Erect Trusses All Size Buildings Cont.

Install Rafter Tie and Rafter Spacer

10x8 Parts List				
□ 1	CG	Rafter Tie	1 x 2 x 9 1/8"	2.5 x 5 x 231.4cm
□ 4	BU	Rafter Spacer	1x2x21 1/4"	2.5 x 5 x 54cm

Refer to Step that correlates to the size building you are installing.

6C. 10 x 8

Starting with the window side single gusset rafter, place **CG Rafter Tie** in notch as shown (leaving 3/4" gap **A**) attach using one 2" (5cm) nail. Next attach **BU Rafter Spacer** using three 1 1/4" (3cm) screws. Continuing in this manner until all rafters are completed will ensure proper spacing between rafters.

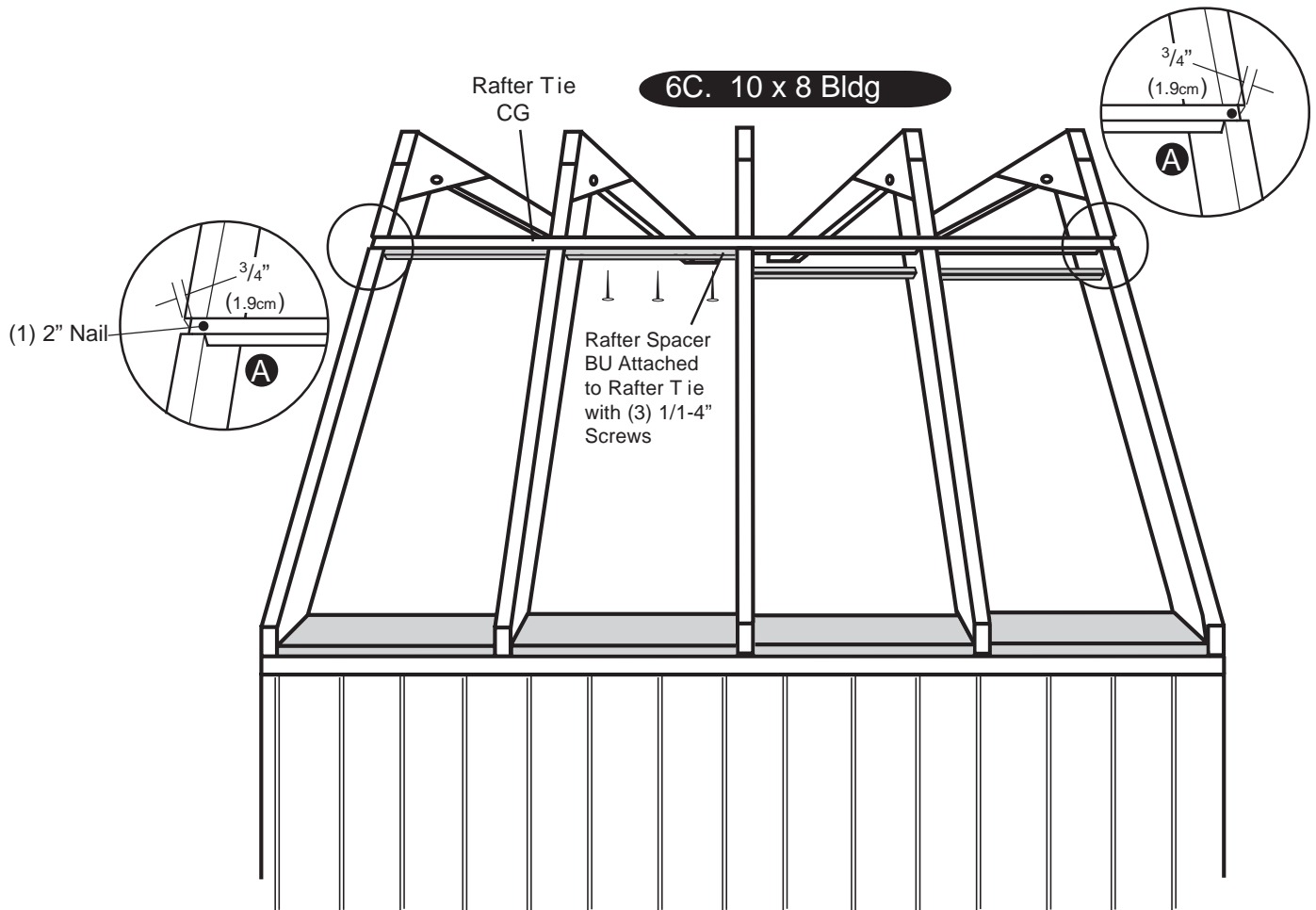

Install Rafter Tie and Rafter Spacer.

Refer to Step that correlates to the size building you are installing.

6C. 10 x12 & 10 x 16

Starting with the left side single gusset rafter, place **CG Rafter Tie** in notch as shown (leaving 3/4" gap **A**) attach using one 2" (5cm) nail. Next attach **BU Rafter Spacer** using three 1 1/4" (3cm) screws. Continuing in this manner until all rafters are completed will ensure proper spacing between rafters.

10x12 Parts List				
□ 1	CG	Rafter Tie	1 x 2 x 91 1/8"	2.5 x 5 x 231.4cm
□ 1	CN	Rafter Tie	1 x 2 x 46 1/4"	2.5 x 5 x 117.4cm
□ 6	BU	Rafter Spacer	1x2x21 1/4"	2.5 x 5 x 54cm

10x16 Parts List				
□ 1	CG	Rafter Tie	1 x 2 x 91 1/8"	2.5 x 5 x 231.4cm
□ 2	CN	Rafter Tie	1 x 2 x 46 1/4"	2.5 x 5 x 117.4cm
□ 8	BU	Rafter Spacer	1x2x21 1/4"	2.5 x 5 x 54cm

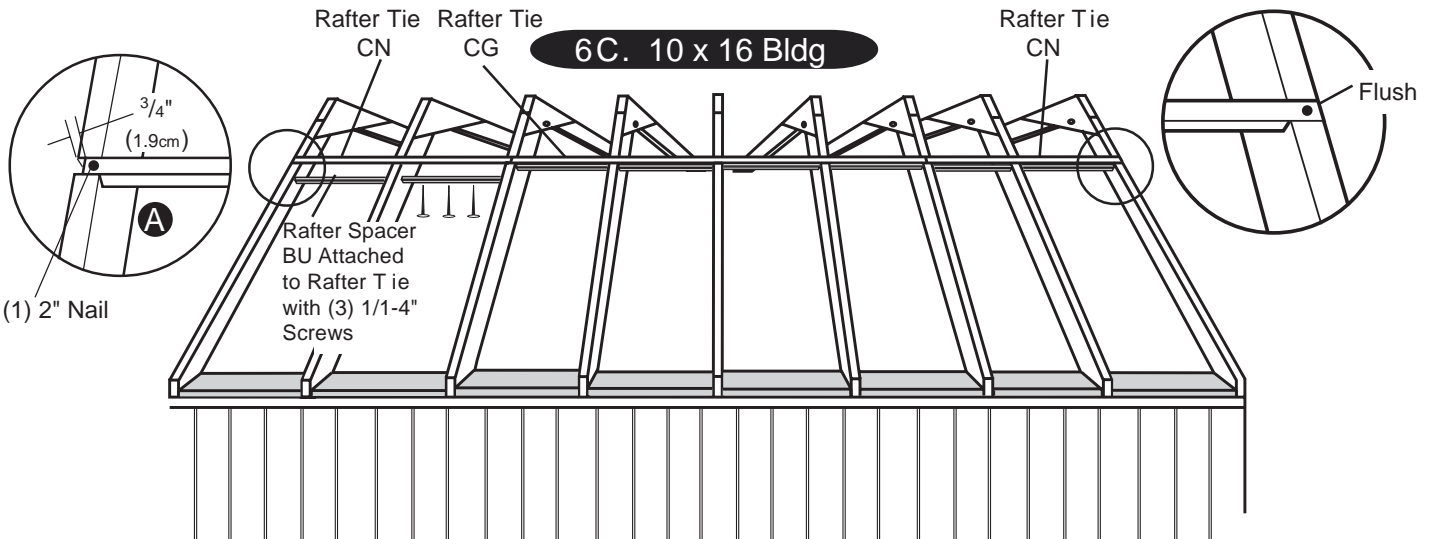
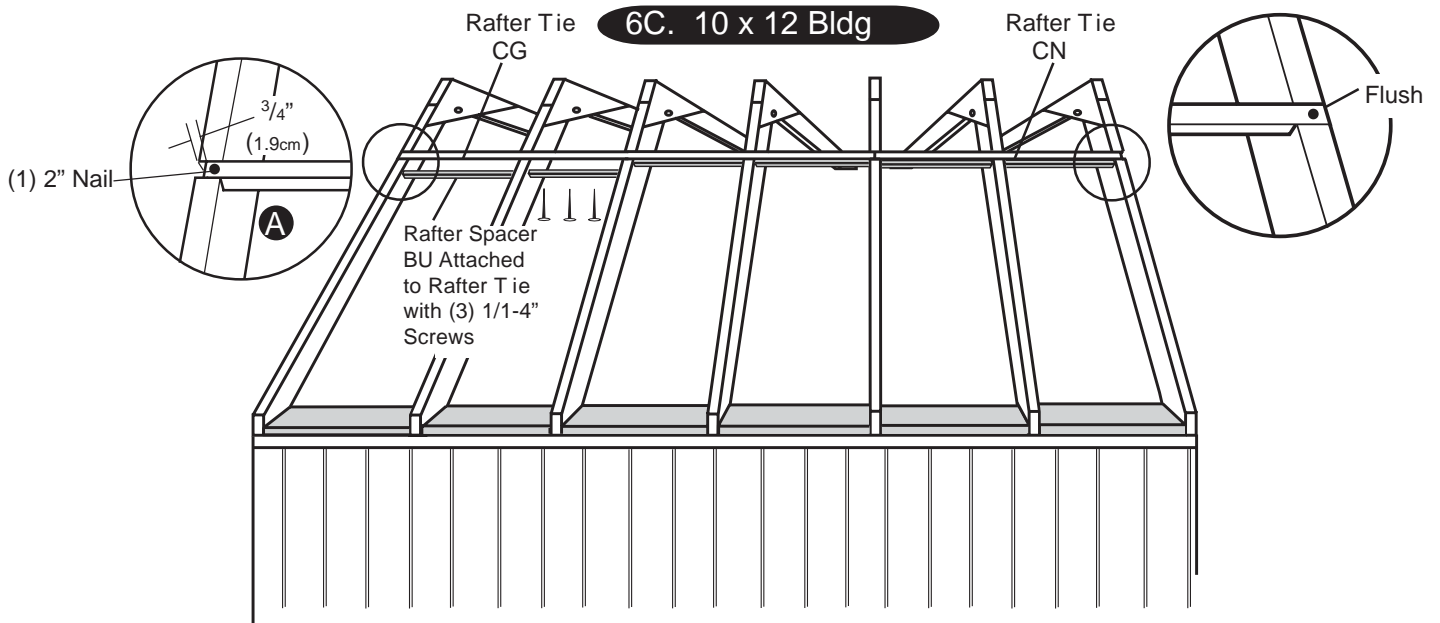

7 Gable Ends

□ 2	¹ / _L / _{1R}	Gable Panels
□ 2	¹ / _L / _{1R}	Gable Spacer

NOTE: A 1/2" PVC or Copper Pipe may be inserted into gusset holes for hanging plants (Piping not included in Kit).

7A. Place **Gable Panel** as shown and nail in place using 2" (5cm) nails spaced 8" (30cm).

7B. Place **Gable Spacer** above gable panel as shown and attach using five 2" (5cm) nails.

7C. Completed Gable End.

Repeat same steps for opposite side of building.

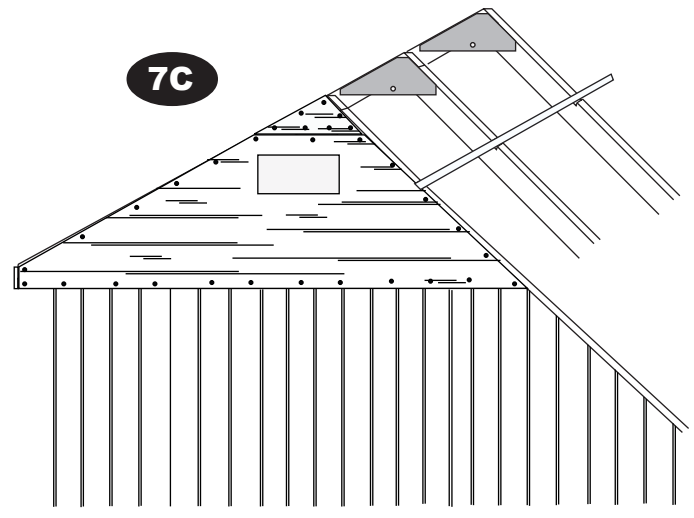
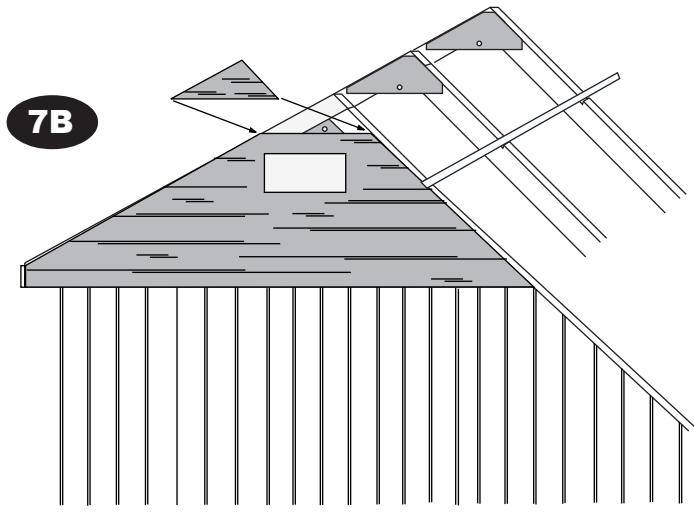
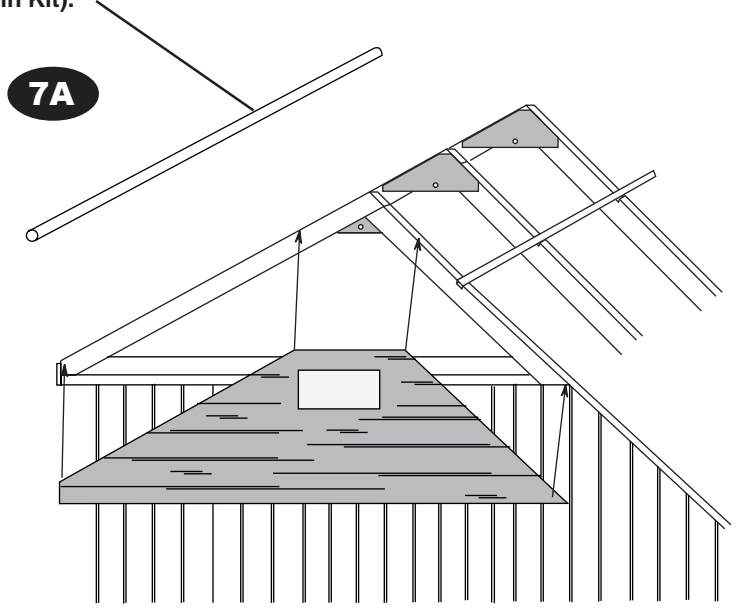

8 Installing Roof Panels

10 X 8 Installation

☐ 1	8A*	Roof panel	48" x 92 ¹ / ₄ "	122 X 234cm
☐ 1	8B*	Roof Panel	15 ⁷ / ₈ " x 92 ¹ / ₄ "	40 X 234cm
☐ 1	8C*	Roof panel	23 ⁵ / ₈ " x 92 ¹ / ₄ "	60 X 234cm

* Refers to step Panel is used

8A. Install first roof panel 48"x92¹/₄" (122 X 234cm) on tall wall and nail in sequence shown using four 2"(5cm) nails.

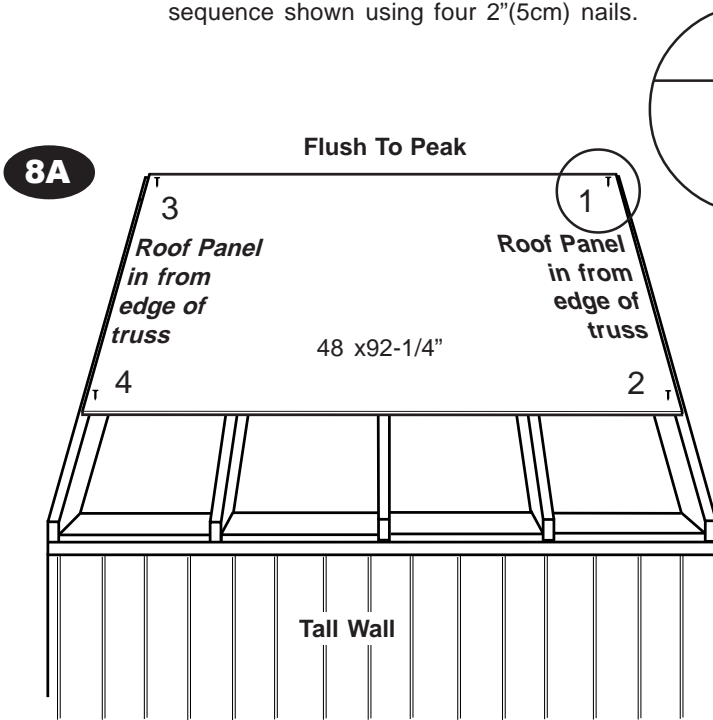

8B. Install second roof panel 15⁷/₈"x92¹/₄" (40 X 234cm) same as first. Once both roof panels are in place secure to trusses using 2" (5cm) nails spaced 8" (20cm) as shown.

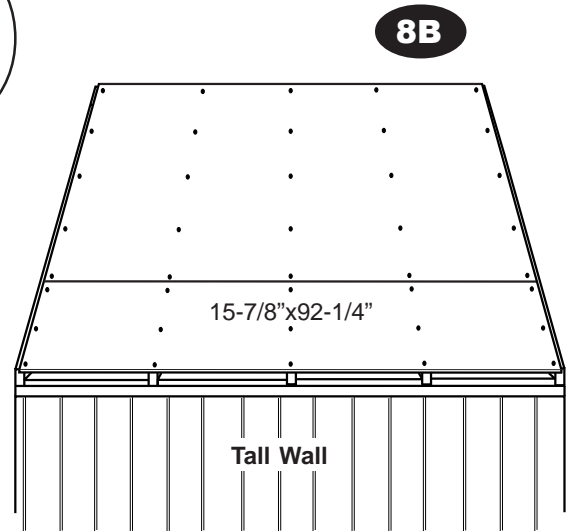

8C. Install third roof panel 23⁵/₈"x92¹/₄" (60 X 234cm) on Short Wall in same manner as tall wall. Once roof panel is in place secure to trusses using 2" (5cm) nails spaced 8" (20cm) as shown.

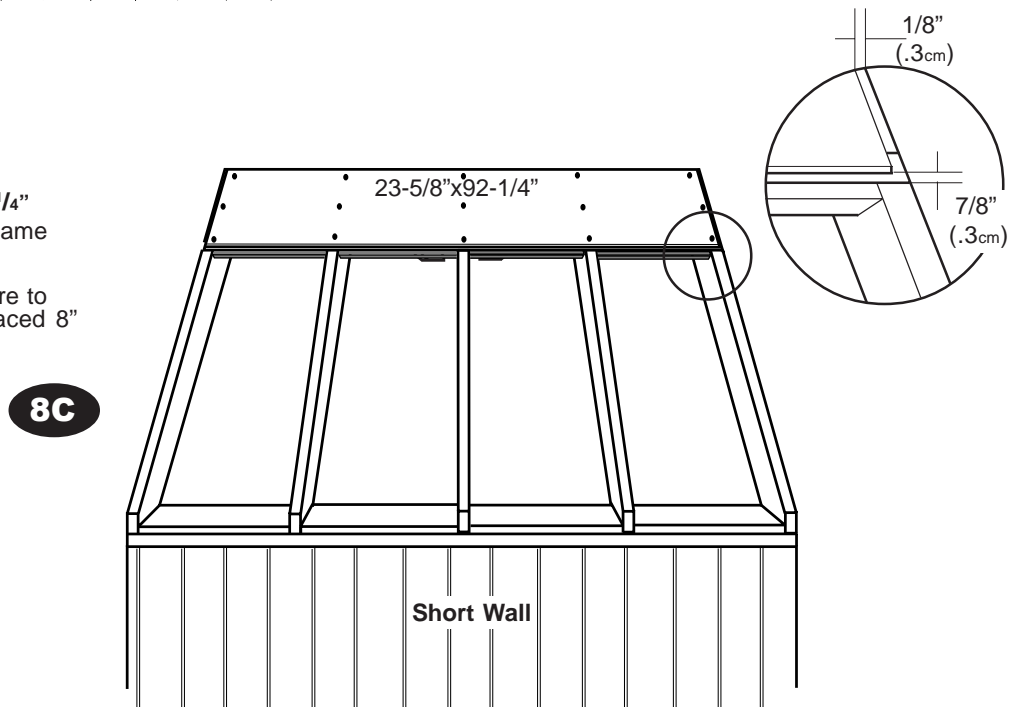

8 Installing Roof Panels

10 x 12 Installation

□ 1	8A*	Roof panel	48 x 92 ¹ / ₄ "	122X234cm
□ 1	8A*	Roof panel	48 x 45 ¹³ / ₁₆ "	122X116.4cm
□ 1	8B*	Roof Panel	15 ⁷ / ₈ x 92 ¹ / ₄ "	40X234cm
□ 1	8B*	Roof Panel	15 ⁷ / ₈ x 45 ¹³ / ₁₆ "	40X116.4cm
□ 1	8C*	Roof Panel	23 ⁵ / ₈ x 92 ¹ / ₄ "	60.6X234cm
□ 1	8C*	Roof Panel	23 ⁵ / ₈ x 45 ¹³ / ₁₆ "	60.6X116.4cm
□ 1	8C*	Roof panel	72 x 45 ¹³ / ₁₆ "	183X116.4cm

Substitute 2 Glass Panels for Glass Extender on the above item.

* Refers to step Panel is used

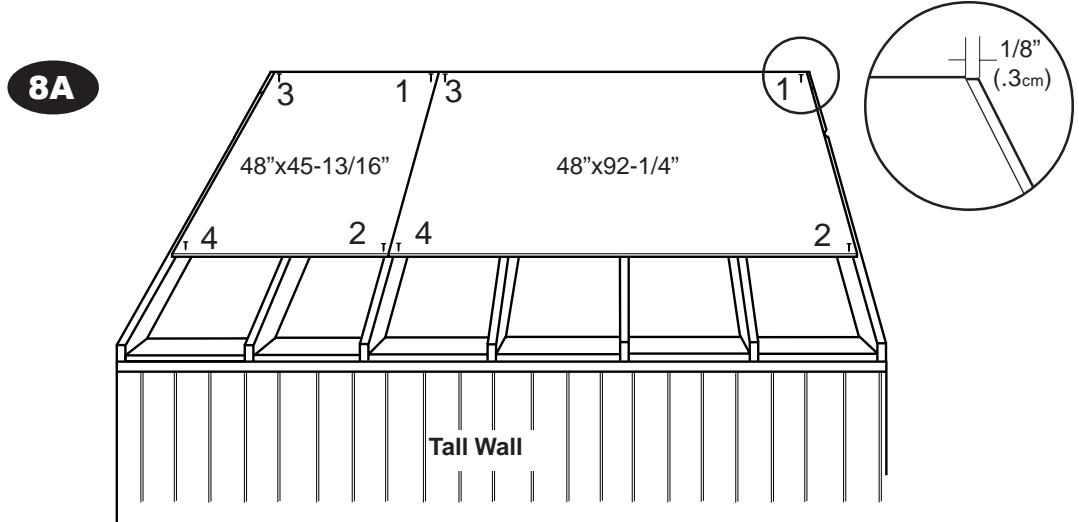

8A. Install first roof panel **48" X 92¹/₄" (122 X 234cm)** on tall wall, and nail in sequence shown using four 2" (5cm) nails. Next install **48" x 45¹³/₁₆" (122 x 116.4cm)**. Nail in sequence shown using four 2" (5cm).

8B. Install lower roof panels along tall wall using one **15⁷/₈" X 92¹/₄" (40 X 234cm)** and one **15⁷/₈" X 45¹³/₁₆" (40 X 116.4cm)** in the same manner as step 8A.

Once all roof panels are in place secure to trusses using 2" (5cm) nails spaced 8" (20cm) as shown.

8C. Install upper roof panels along short wall as shown using one **23⁵/₈" X 92¹/₄" (60 X 234cm)** and one **23⁵/₈" X 45¹³/₁₆" (60 X 116.4cm)**. Nail to trusses in same manner as step 8A and 8B.

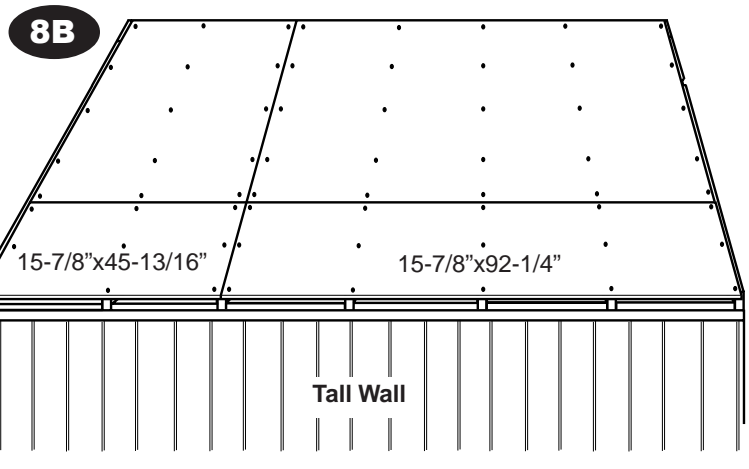

FOR SOLID ROOF EXTENDER

Install lower roof panel along short wall as shown. Use one **72" x 45¹³/₁₆" (183 x 116.4cm)**. Substitute 2 glass panels for glass extender.

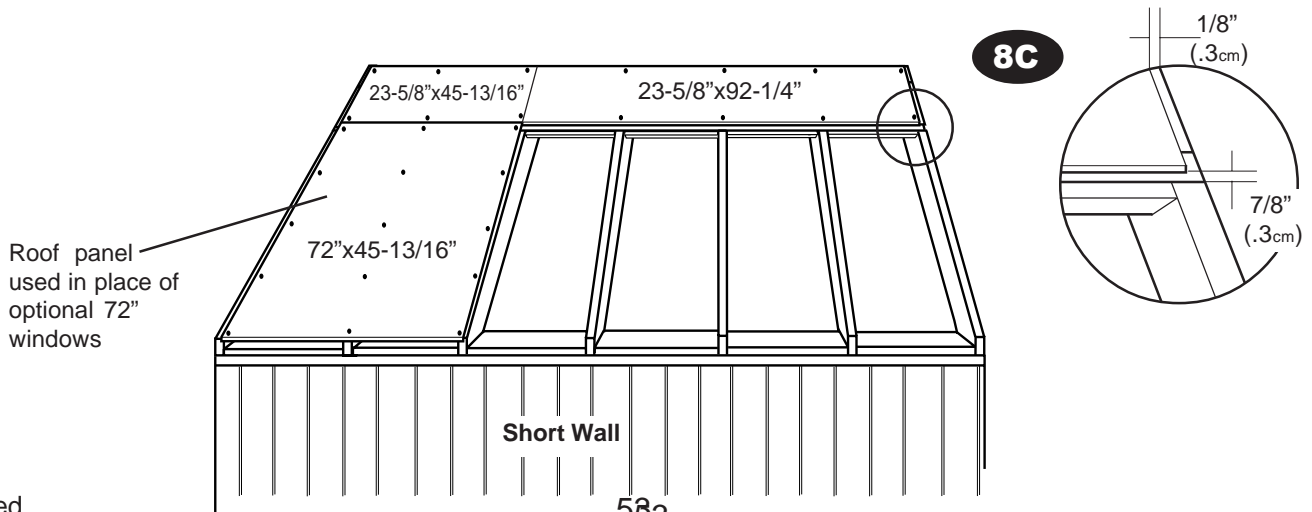

8 Installing Roof Panels

10 x 16 Installation

□ 1	8A*	Roof panel	48 x 92 ¹ / ₄ "	122X234cm
□ 2	8A*	Roof panel	48 x 45 ¹³ / ₁₆ "	122X116.4cm
□ 1	8B*	Roof Panel	15 ⁷ / ₈ x 92 ¹ / ₄ "	40X234cm
□ 2	8B*	Roof Panel	15 ⁷ / ₈ x 45 ¹³ / ₁₆ "	40X116.4cm
□ 1	8C*	Roof Panel	23 ⁵ / ₈ x 92 ¹ / ₄ "	60.6X234cm
□ 2	8C*	Roof Panel	23 ⁵ / ₈ x 45 ¹³ / ₁₆ "	60.6X116.4cm
□ 2	8C*	Roof panel	72 x 45 ¹³ / ₁₆ "	182X116.4cm

Substitute 2 Glass Panels for Glass Extender.

* Refers to step Panel is used

8A. Install first roof panel 48"X 92¹/₄" (122 X 234cm) on tall wall, and nail in sequence shown using four 2"(5cm) nails. Next install two 48"x 45¹³/₁₆" (122 x 116.4cm). Nail in sequence shown using four 2"(5cm).

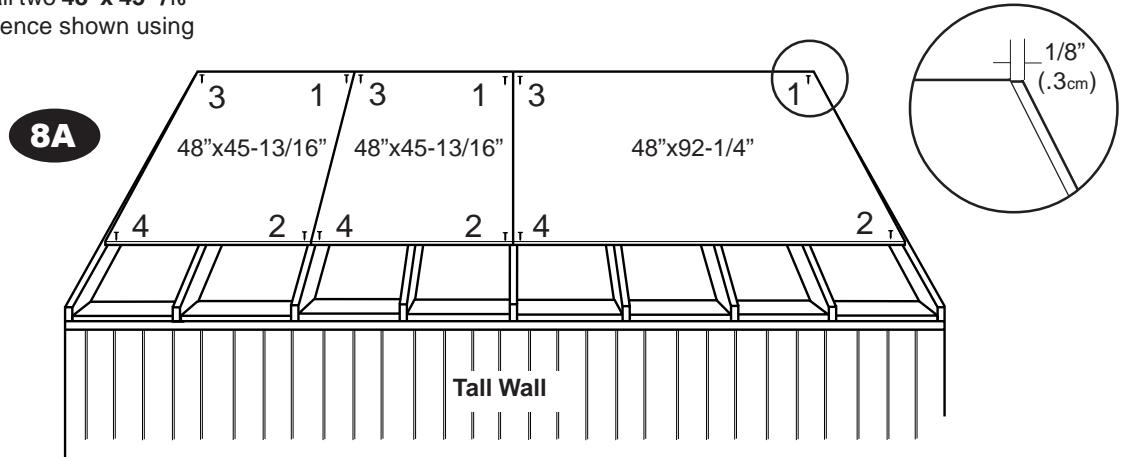

8B. Install lower roof panels along tall wall using one 15⁷/₈"X 92¹/₄" (40 X 234cm) and two 15⁷/₈"X 45¹³/₁₆" (40 X 116.4cm) in the same manner as step 8A.

Once all roof panels are in place secure to trusses using 2" (5cm) nails spaced 8" (20cm) as shown.

8C. Install upper roof panels along short wall as shown using one 23⁵/₈"X 92¹/₄" (60 X 234cm) and two 23⁵/₈"X 45¹³/₁₆" (60 X 116.4cm). Nail to trusses in same manner as step 8A and 8B.

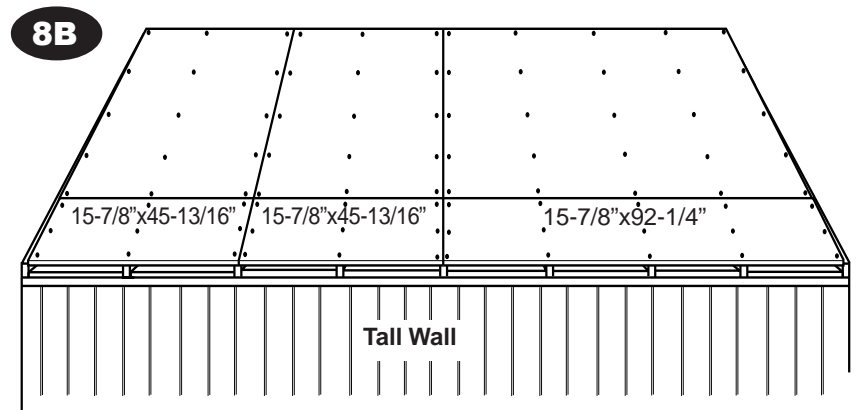

FOR SOLID ROOF EXTENDER

Install lower roof panel along short wall as shown. Use one 72"x 45¹³/₁₆" (183x116.4cm). Substitute 2 glass panels for glass extender.

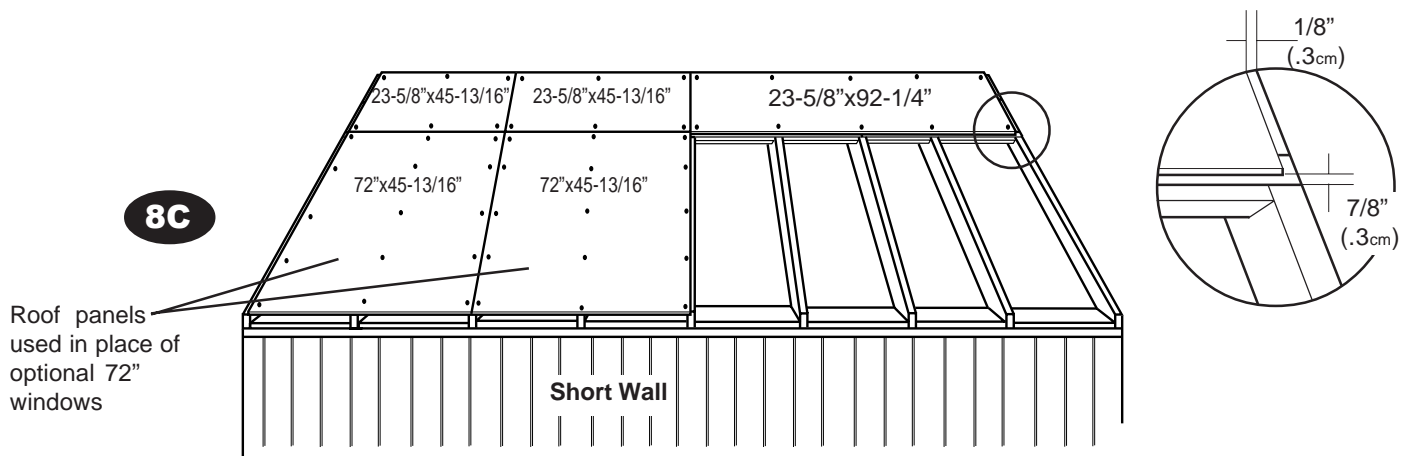

10 Installing Gable Trim

□ 2	JB	Gable Trim	1 x 4 x 42 ⁵ / ₈ "	2 x 10 x 130cm
□ 2	KN	Gable Trim	1 x 4 x 87 ⁷ / ₈ "	2 x 10 x 223.2cm
□ 2	HN	Gable Trim	1 x 3 x 79 ⁵ / ₁₆ "	2 x 7.6 x 201.4cm
□ 2	--	Plywood Gable Cap	9 ⁷ / ₈ " x 29 ⁵ / ₁₆ "	24 x 74cm
□ 2	--	Soffit End Cap	7 ⁷ / ₈ x 3 ¹⁵ / ₁₆ x 7 ¹ / ₂ "	20x10x19cm

10A. Place **Plywood Gable Cap** flush to top of roof panel.

Hint Use a scrap piece of wood to help align to top of roof

Secure **Plywood Gable Cap** in place using seven 2" (5cm) nails.

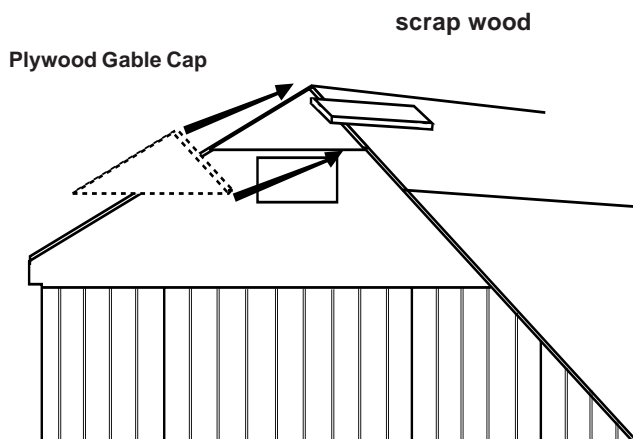

10A

10B. Place **JB** and **KN** Tight to **Gable Cap** and flush with top of roof panel.

Place **Soffit End Cap** Flush with **JB** and top of roof Panel.

Nail in place with 2" (5cm) nails.

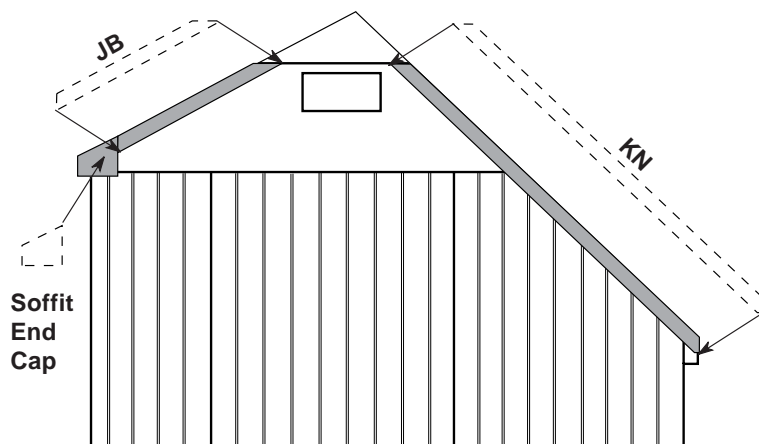

10B

10C. Place **HN** as shown covering wall joint, and in between **Soffit End Cap** and **KN**.

Nail in place using 2" (5cm) nails.

10C

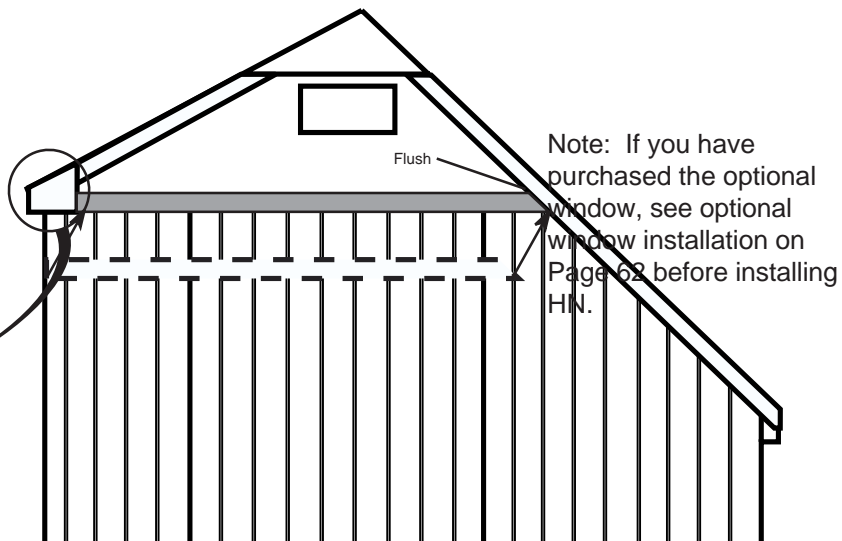
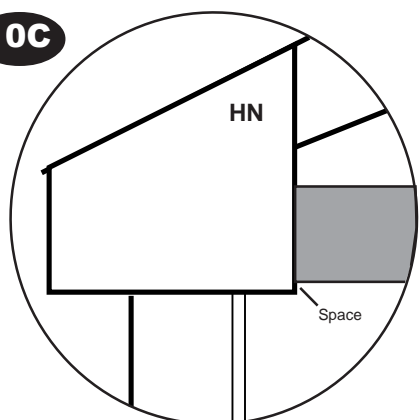

Note: If you have purchased the optional window, see optional window installation on Page 62 before installing HN.

11 Install Corner Trim

□ 2	CK	Corner Trim w/angle	1 x 3 x 38 ¹ / ₂ "	2 x 6 x 98cm
□ 2	GT	Corner Trim	1 x 3 x 71 ¹ / ₂ "	2 x 6 x 181.6cm
□ 2	CS	Corner Trim	1 x 2 x 72"	2 x 5 x 183cm
□ 2	CF	Corner Trim	1 x 2 x 35 ¹ / ₄ "	2 x 5 x 89cm

11A. Assemble Corner Trim **GT** and Corner Trim **CS** as shown using seven 2" (5cm) nails. Offset **GT** 1/2" at top and flush at bottom.

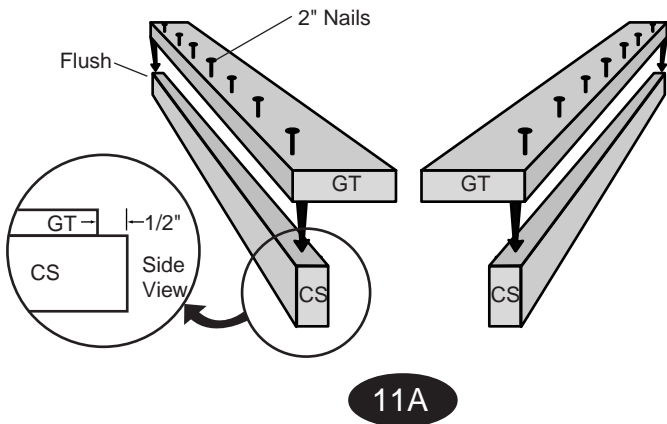

11B. Assemble Corner Trim **CK** and Corner Trim **CF** as shown using five 2" (5cm) nails. Assemble two of these corners making sure to assemble one right and one left Corner Trim Assembly.

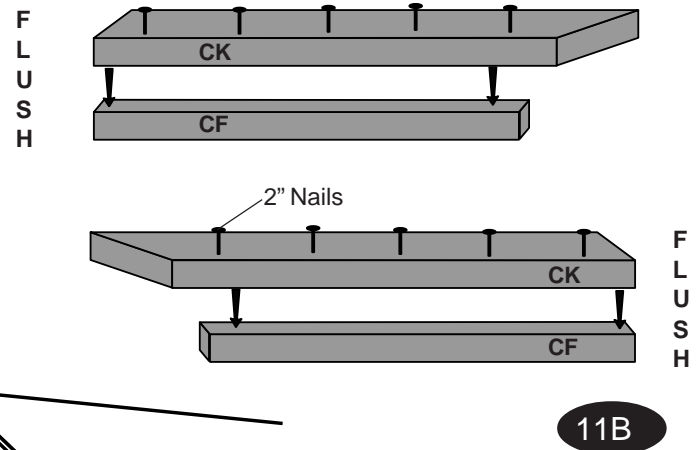

11C. Attach corner trim with 2" nails as shown.

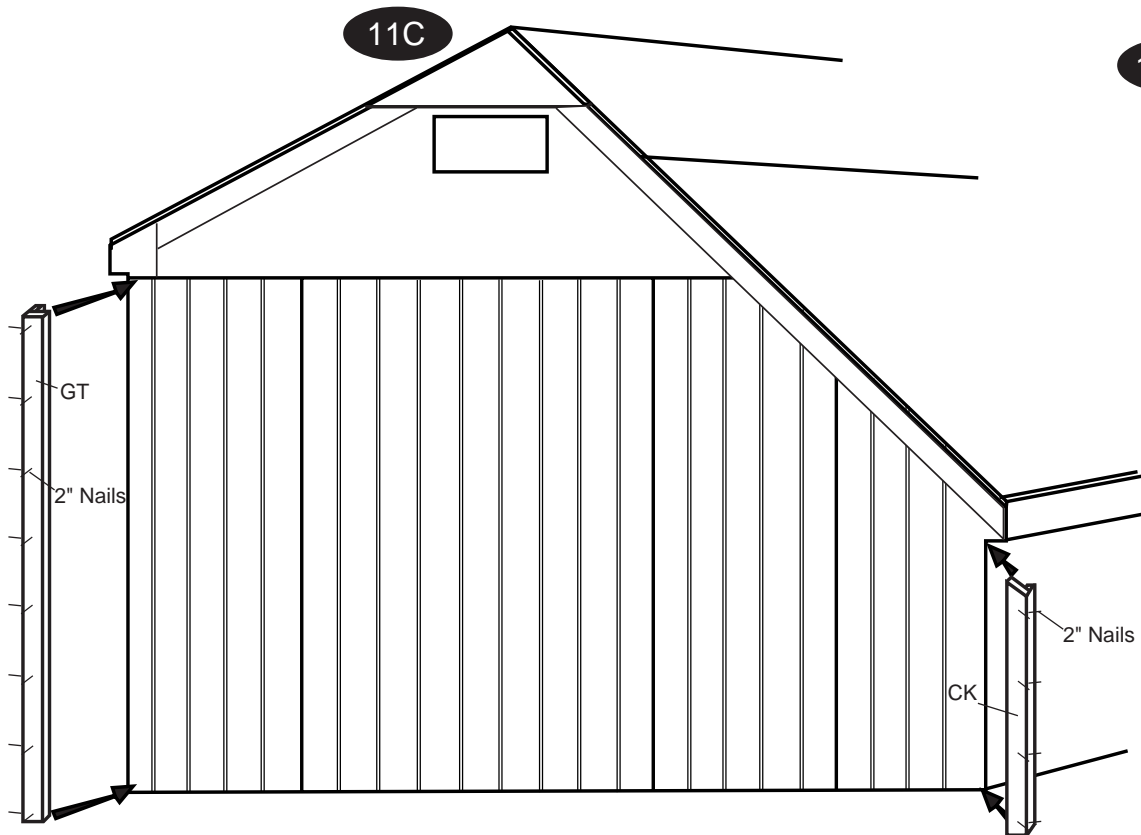

12 Install Fascia Trim

All Building Sizes

12. Install Fascia KT angled for 10x8 and KT, HZ for 10x12 and 10x16 on Short Wall. Keep flush with bottom of 2x6 top plate, if using more than one piece of fascia per side, butt tightly next to one another. Secure using 2" (5cm) nails spaced every 12" (30cm).

Install Fascia(s) to tall wall side of building in the same manner using KI for 10x8 and KI, IJ for 10x12 and 10x16.

10 x 8 Building Parts List					
□ 1	KT	Fascia Trim <i>angled</i>	1 x 4 x 93 ³ / ₈ "	2 x 10 x 237cm	
□ 1	KI	Fascia Trim	1 x 4 x 93 ³ / ₈ "	2 x 10 x 237cm	

10 x 12 Building Parts List					
□ 1	KI	Fascia Trim	1 x 4 x 93 ³ / ₈ "	2 x 10 x 237cm	
□ 1	IJ	Fascia Trim	1 x 4 x 45 ¹ / ₂ "	2 x 10 x 115.5cm	
□ 1	KT	Fascia Trim <i>angled</i>	1 x 4 x 93 ³ / ₈ "	2 x 10 x 237cm	
□ 1	HZ	Fascia Trim <i>angled</i>	1 x 4 x 45 ¹ / ₂ "	2 x 10 x 115.5cm	

10 x 16 Building Parts List					
□ 1	KI	Fascia Trim	1 x 4 x 93 ³ / ₈ "	2 x 10 x 237cm	
□ 2	IJ	Fascia Trim	1 x 4 x 45 ¹ / ₂ "	2 x 10 x 115.5cm	
□ 1	KT	Fascia Trim <i>angled</i>	1 x 4 x 93 ³ / ₈ "	2 x 10 x 237cm	
□ 2	HZ	Fascia Trim <i>angled</i>	1 x 4 x 45 ¹ / ₂ "	2 x 10 x 115.5cm	

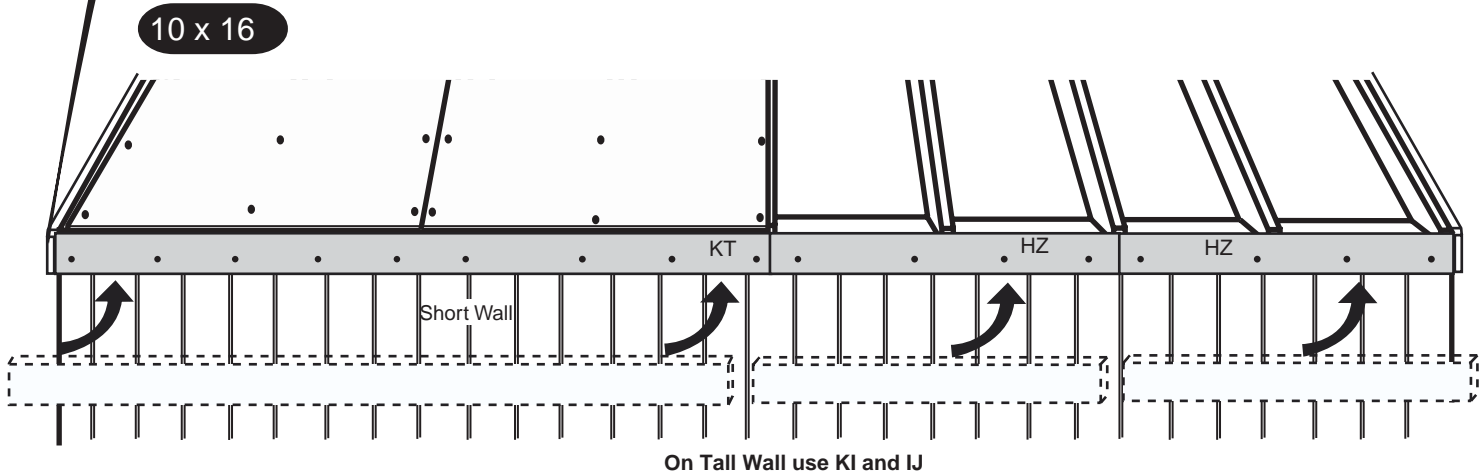
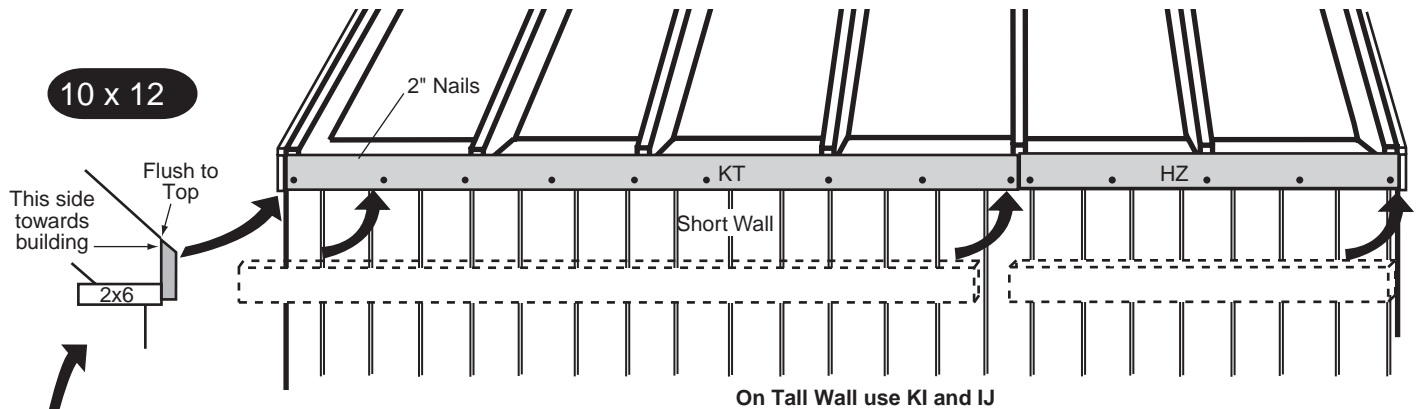
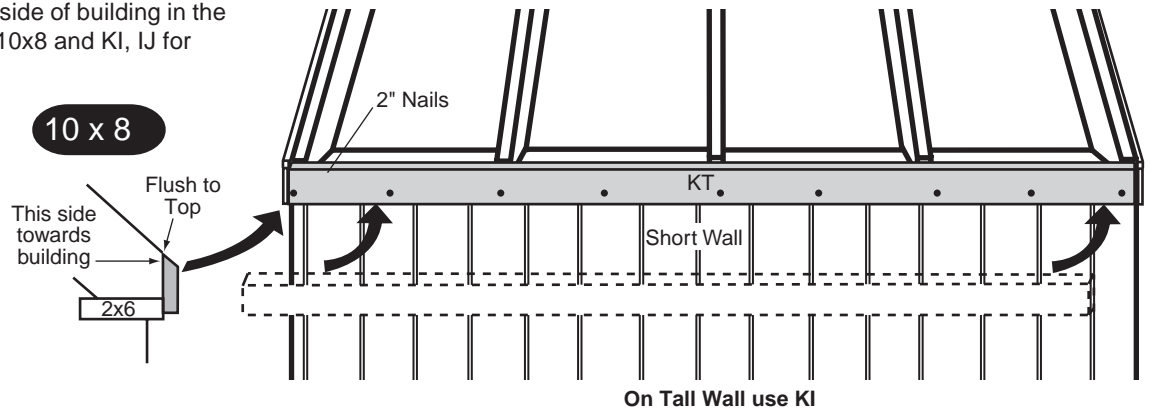

13 Installing Door

All Building Sizes

Building Parts List			
<input type="checkbox"/>	1 pcs.	—	Doors
<input type="checkbox"/>	1 pcs.	—	Continuous Hinge
<input type="checkbox"/>	2 pcs.	ZO	Door Trim 5/8 x 3 x 72"

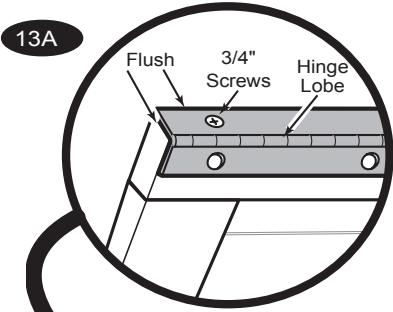

13-A: Position Continuous Hinge on edge of Door with lobe up and overhanging outside face edge of Door. Piano Hinge should be flush to top of Door as shown. Secure with twelve 3/4" (1.9cm) Hinge screws. Make sure there is a screw in each hole.

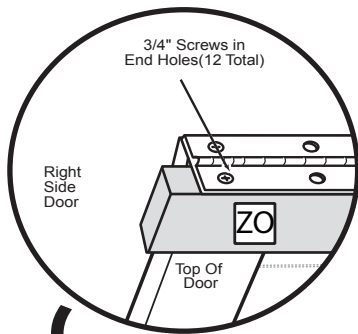
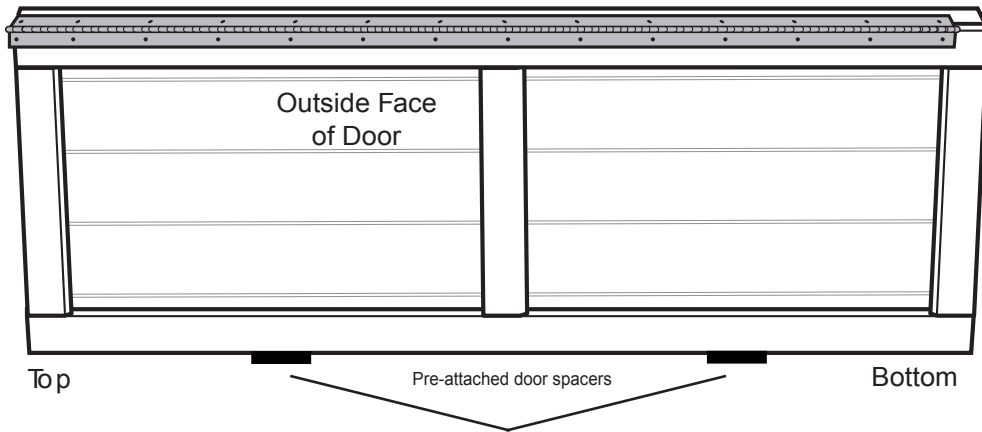

Important Note: Door can be hinged Right or left, based on preference, by changing which end of door "ZO" overhangs.

Remove Door Spacers on Hinge side of Door only.

13B-C

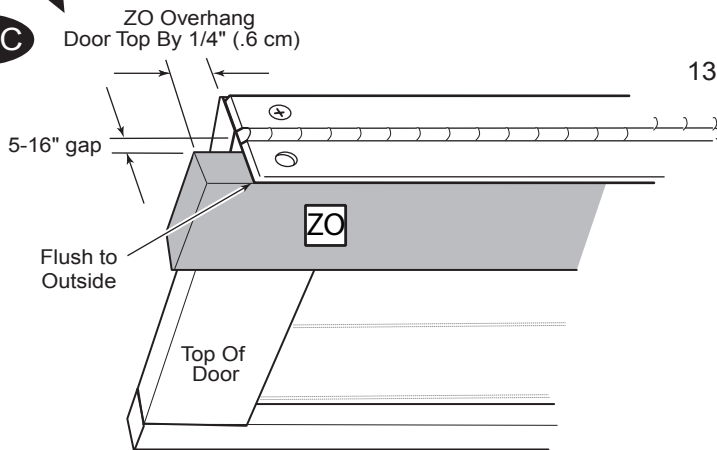

13-B: Position (ZO) under Hinge on outside face of Door, overhanging top of Door by 1/4"(.6cm), and overhang 1/4" from top and edge of Continuous Hinge. Create a 5/16" gap between door and (ZO) before attaching with screws.

Installing Door cont.

□ 1	-- Door Stop	1/2 x 3/4 x 68"	20 x 10 x 19cm
□ 2 DH	-- Door Stile	5/8x3x 30 ⁵ / ₈ "	2 x 4 x 77.8cm

13-D: Cut bottom plate in door opening flush to studs. Install 1/2 x 3/4 x 68" Door Stop with 1-1/2" finish nails. Keep 5/8" to outside of stud and keep 1/2" side to stud. Use wood glue (not included) for added strength.

Install Door Stiles (DH) with 1" screws to the center of the Doors.

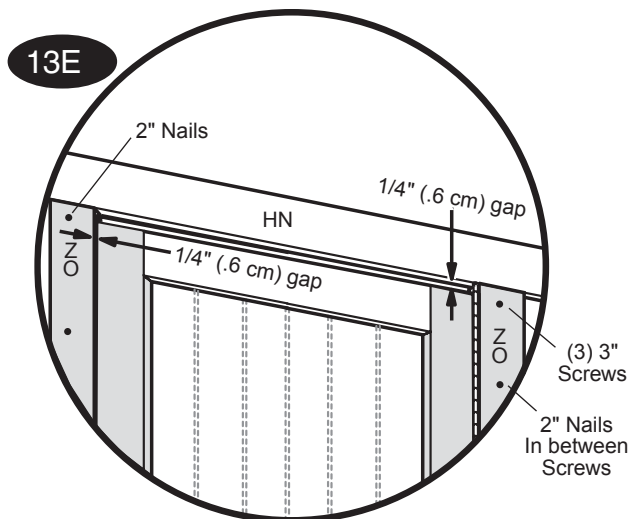
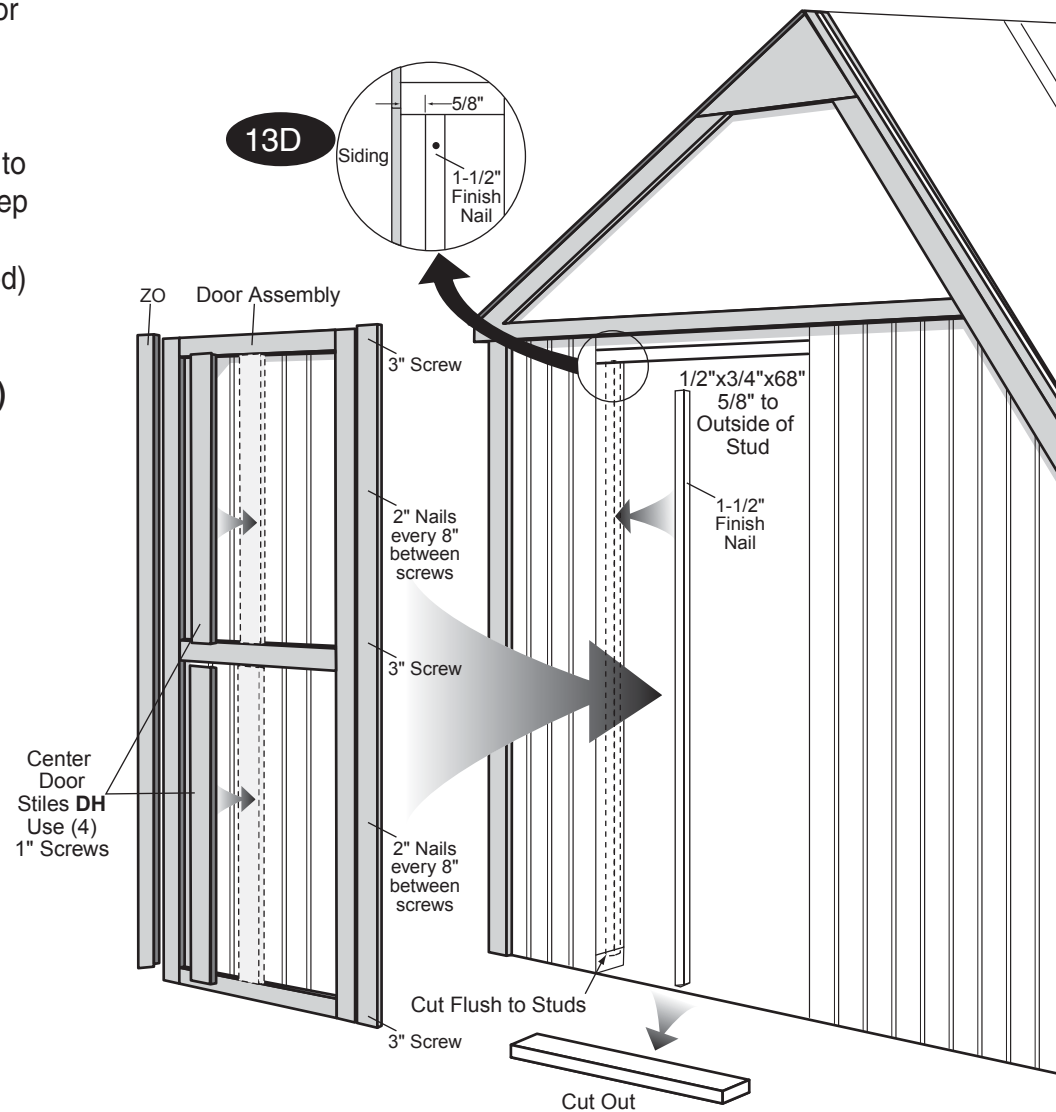

13-E: With two people lift and position Door centered left and right in door opening on Door Wall with Door Trim (ZO) against gable trim (HN) or butting to 2x6 overhang on tall wall. Note: 1/4" (.6 cm) overhang at top of Doors. Connect Door Trim (ZO) to Building with three 3" (7.5 cm) screws as shown. Install (ZO) to side of Door. Butt to (HN) on 2x6 overhang and butt to door spacers and nail with 2" nails. Remove Door Spacers at this time and check door operation then finish nailing hinge (ZO) with 2" nails.

13 F

13-F: Attach door stiffeners using 1" screws (28 places)

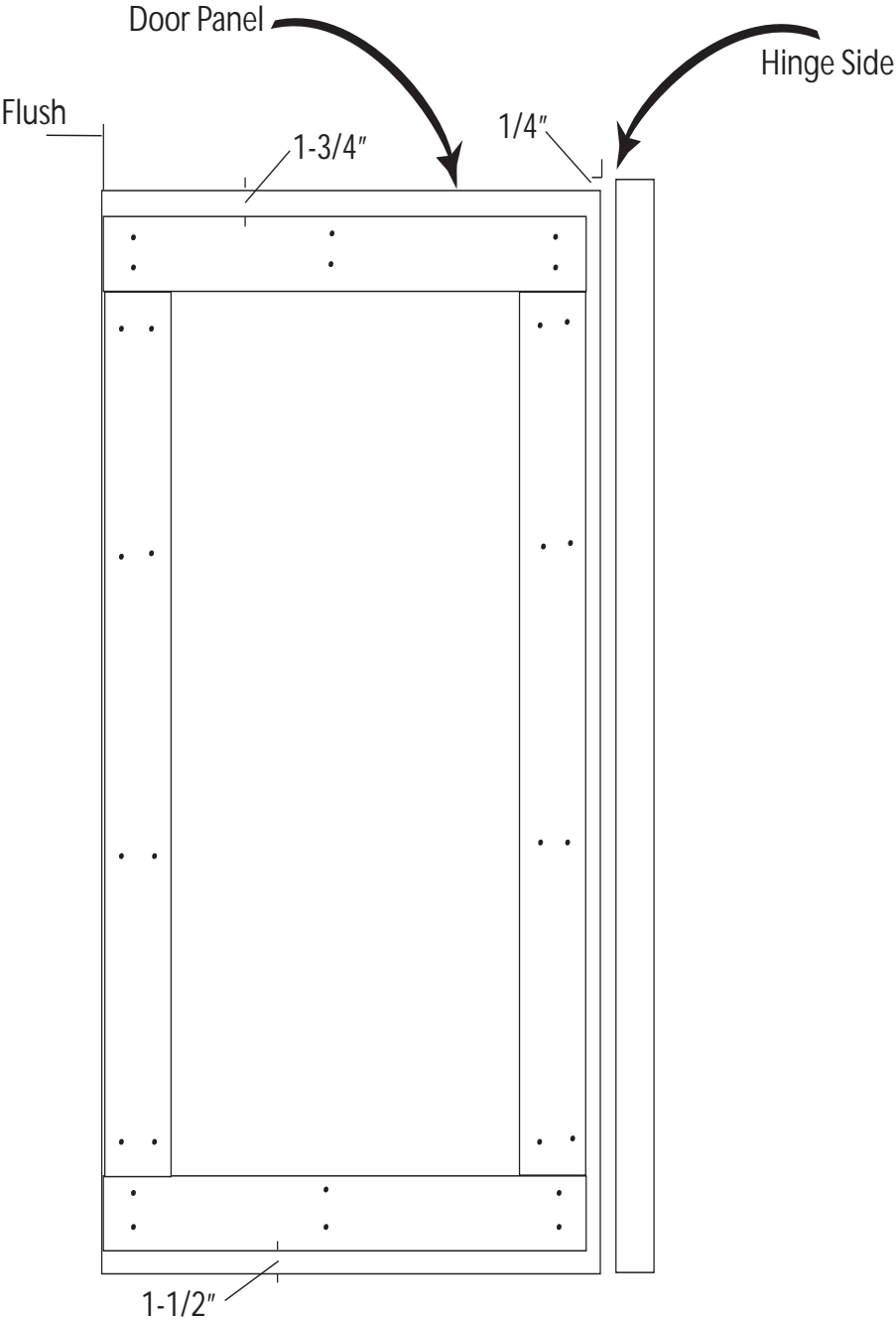

14 Applying Door Handle

□ 1 Door Handle

Door Handle Installation

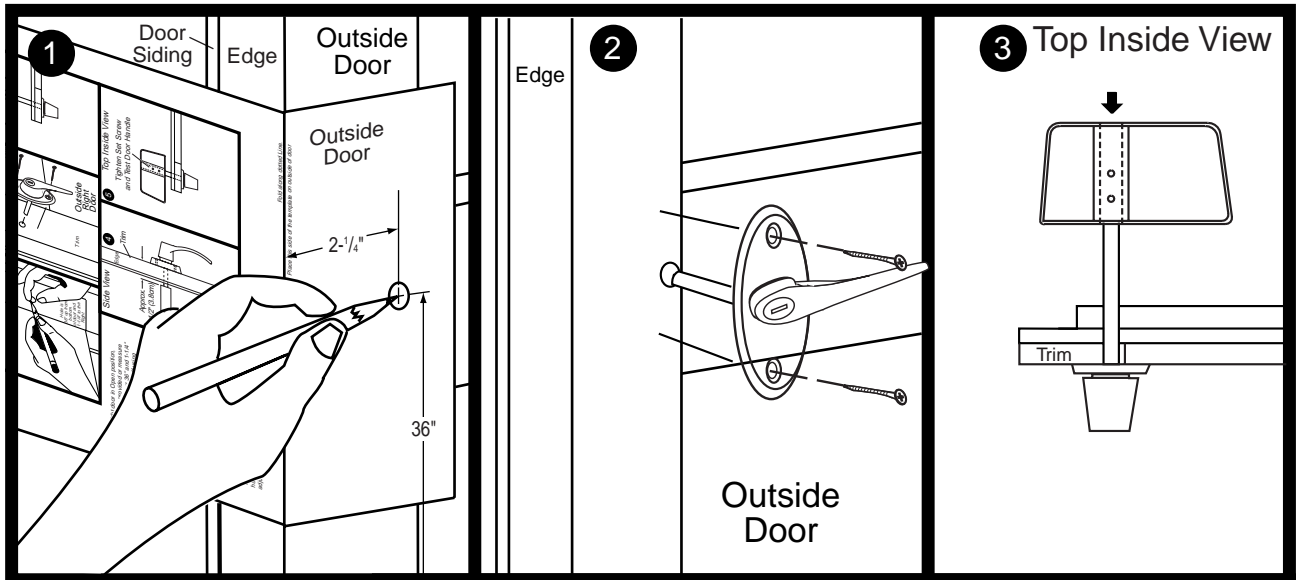

With door in Open position, place template provided on face of Door with center of handle centered on middle horizontal Door Trim.

Step 1, Mark hole location as indicated and drill one 1/2" hole straight through door. Insert Knob assembly through outside of door. With handle horizontal, fasten with screws provided as in step 2. Rotate handle down and position inside handle with long end towards left door as in step 3. Keep the handle back approx 2" from front of door as shown in step 4. Note, depending on the building you purchased, this dimension may vary. Tighten set screw and test handle. Turn handle to the right and shut door. Turn handle back to the left to shut door. Make adjustments accordingly.

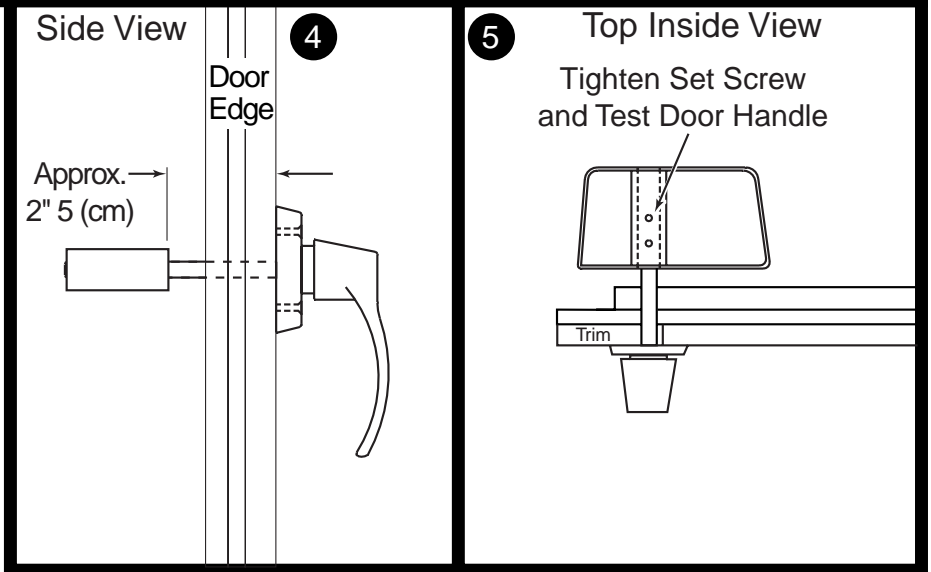

Fold along dotted Line.

Place this side of the template on outside of door

2-1/4"
(5.7cm)

36"
(91.4cm)
From
Bottom
of Door

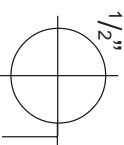

Outside
Door

15 Installing Windows

Follow these basic steps for extender glass options.

15-A: We require metal drip edge (not included) also be applied before shingling and installing windows. Install to all outside edges. See illustration below for more information.

<input type="checkbox"/> 4	--	Solar Windows
<input type="checkbox"/> 3	--	Aluminum Mullion Strip (Narrow)
<input type="checkbox"/> 2	--	Aluminum Mullion Strip (Wide)
<input type="checkbox"/> 2	Roll	Foam Tape

Each 4' Glass Extender		
<input type="checkbox"/> 2	--	Solar Windows
<input type="checkbox"/> 2	--	Aluminum Mullion Strip (Narrow)
<input type="checkbox"/> 1	Roll	Foam Tape

Building Size (Required) not included	Drip Edge
10' x 8'	50 lineal ft.
10' x 12'	60 lineal ft.
10' x 16'	70 lineal ft.

15A

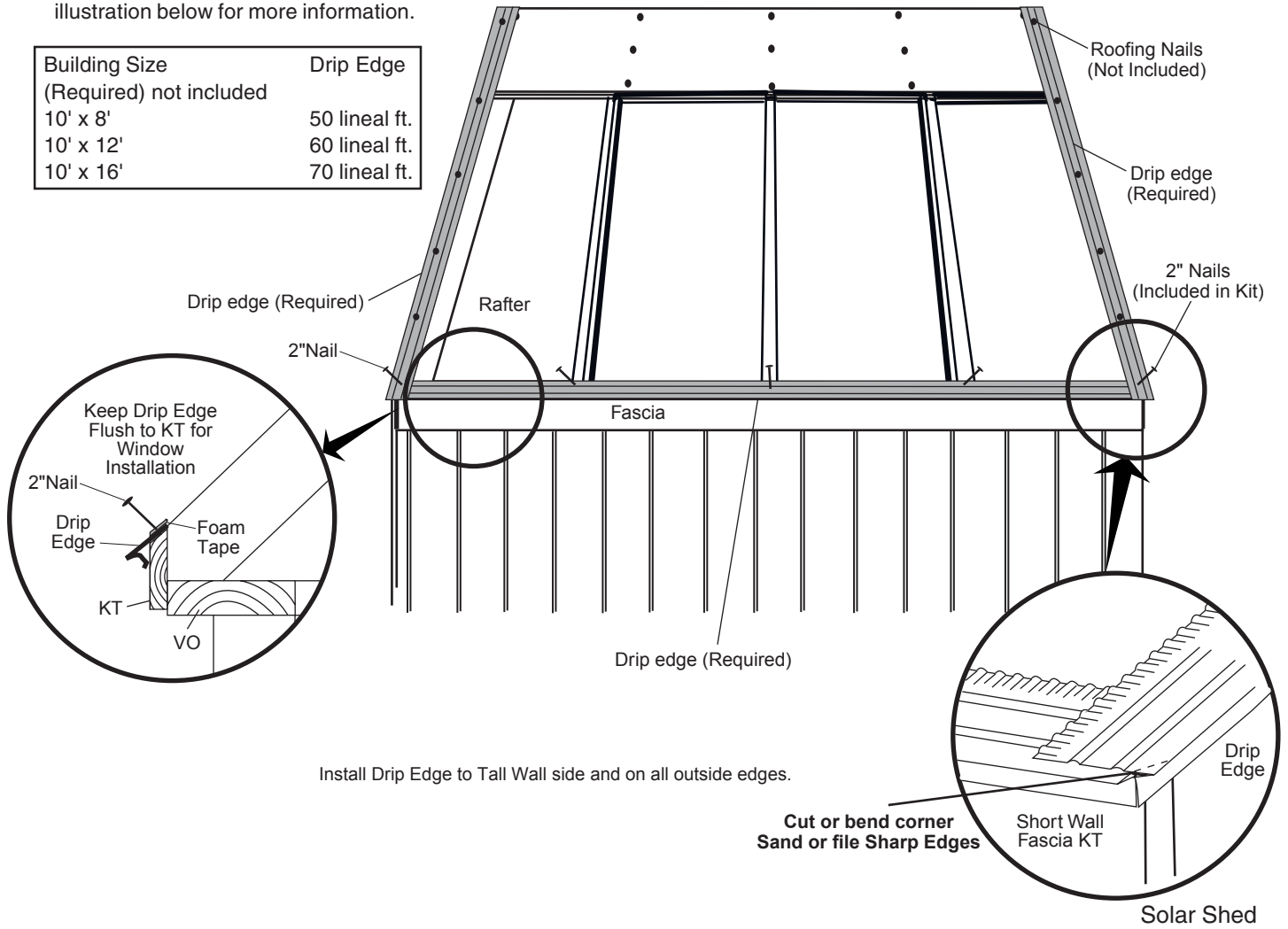

15B

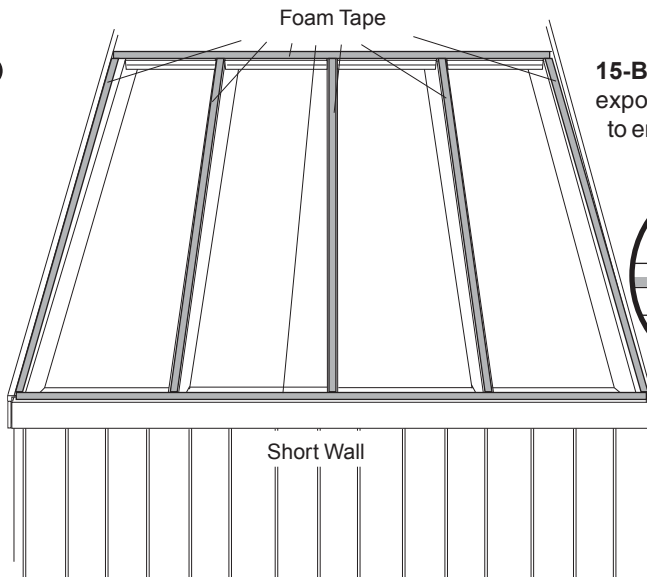

15-B : Before Installing windows place **Foam Tape** on all exposed faces of **Rafters, Rafter Spacers and fascia** to ensure proper seal from the weather.

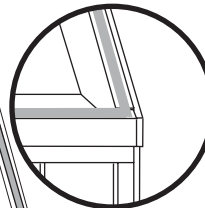

15-C: Place windows in opening between rafters, then secure in place using **Mullion Strips** (Wide to the outside & Narrow to the inside). Mullion Strips will cover outside edges of the window flange and the pan head screws will pass through the mullion strip, between the window flanges into the center of the rafters.

Use one 1 1/4" (3cm) pan head screw for each hole in all mullion strips and tighten snugly.

Do Not Over Tighten Screws!

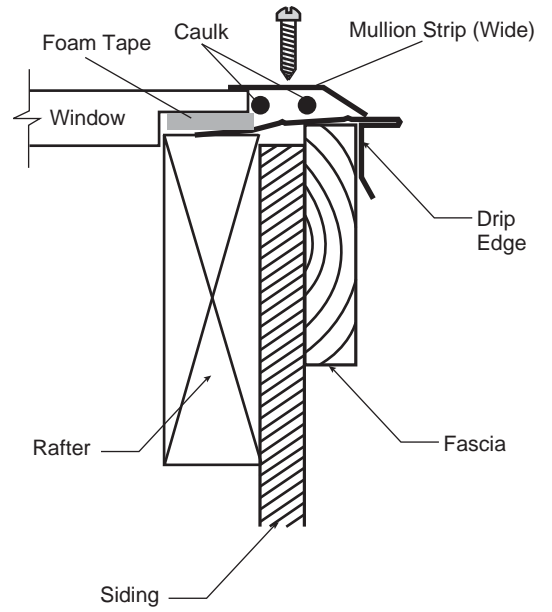

15C

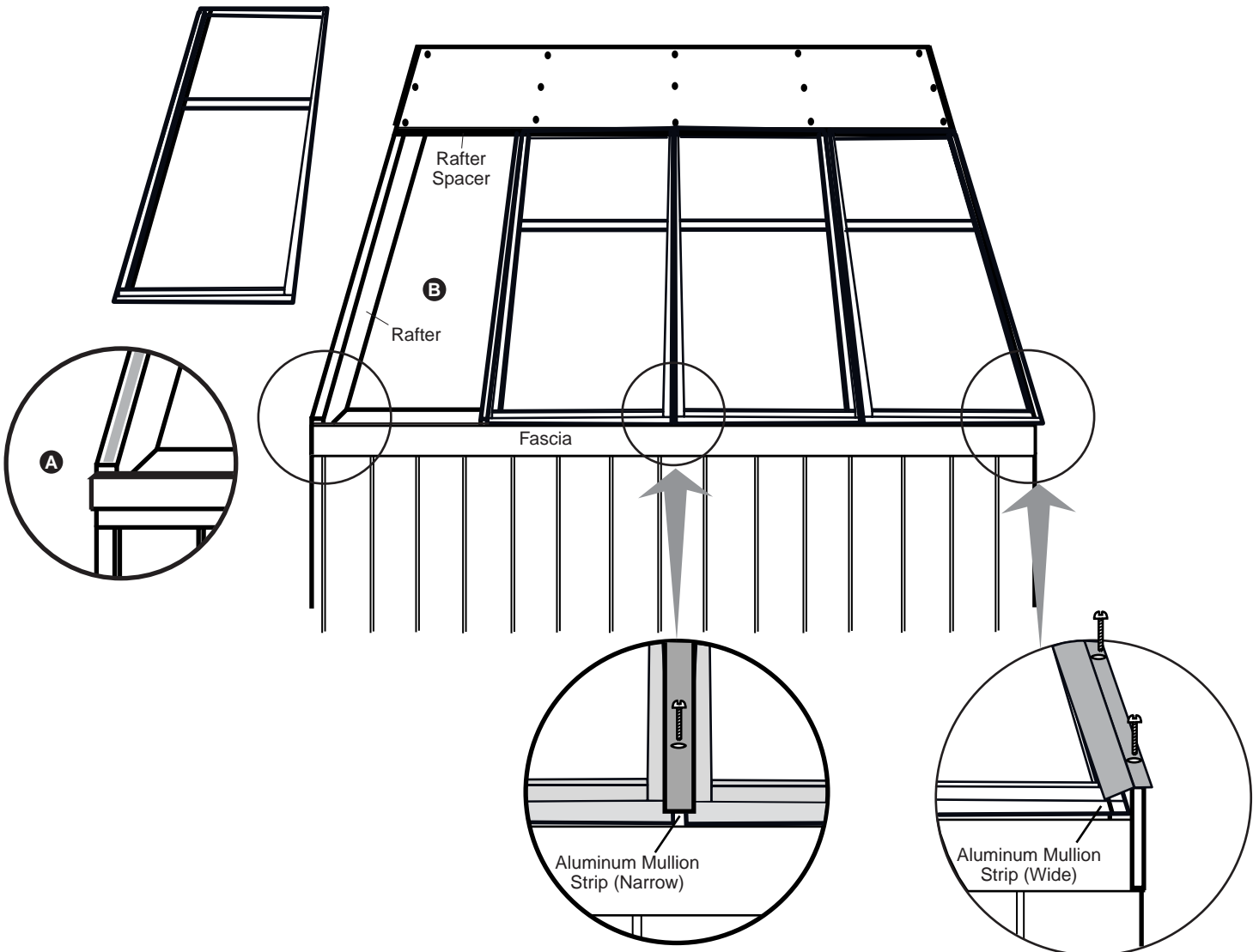

16 Installing Vents

□ 4	--	Adjustable Vents	6 x 12"	15 x 30.5cm
□ 4	--	Exterior Vents	8 x 16"	20.3 x 40.6cm
□ 4	--	Interior Vent Spacer	9 x 15"	23 x 38cm

16. Install **vents** in sequence shown 1 through 3. Screw in place with four 3/4"(2cm) screws in each part.

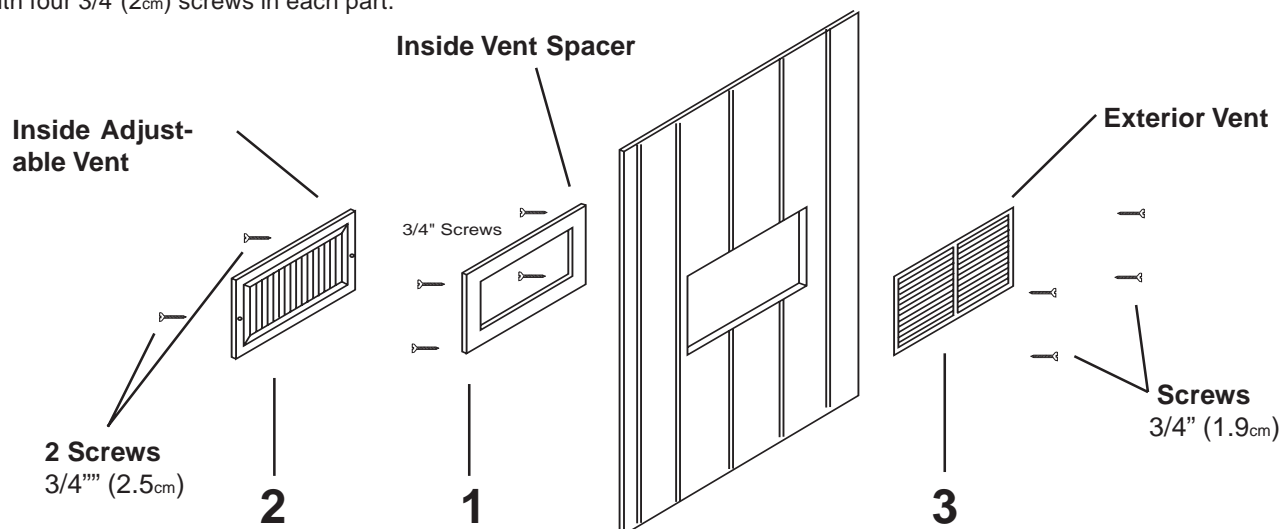

Painting, Shingling and General Maintenance

Your Solar Shed, like your home, requires a certain amount of normal maintenance and care.

Nail Inspection:

After assembly is finished, check the entire building inside and out for any protruding nails. Pound over protruding nails into the wood or cut them off flush.

Caulking

Before painting, you must apply quality exterior (paintable) caulk at all horizontal and vertical seams, between the trim and walls, and all around the door trim. Caulk is not included in the kit.

Painting

Your Solar Shed must be painted with two coats of acrylic latex paint or an opaque latex stain within 30 days of assembly. In order to ensure long life all exposed edges of the exterior siding panels and inside of doors must be sealed. The bottom edges are most important. Periodic refinishing, as weather conditions demand, is also necessary. Paint is not included in the kit. You will need:

Building Size	Exterior Paint or Solid Stain (for Trim)	Exterior Paint or Solid Stain (for Sides)
10' x 8'	1 quart	1 1/2 gallon
10' x 12'	1 1/2 quart	2 gallon
10' x 16'	2 quart	3 gallon

If you intend to use the Solar Shed as a greenhouse, you must paint the inside of the building as well as the wood floor (provided your building has a wood floor).

Building Size	Interior Paint or Solid Stain (for Walls)	Interior Paint or Stain (for Floor)
10' x 8'	1 gallon	1 1/2 quart
10' x 12'	1 1/2 gallon	2 gallon
10' x 16'	2 gallons	3 gallon

Shingling

Your Solar Shed must be shingled. When shingling, follow manufacturer's installation instructions. Shingles and fasteners are not included in the kit. You will need:

Building Size	Shingles (Required)	Drip Edge (Required)
10' x 8'	3 bundle	50 lineal ft.
10' x 12' (Solid Roof Extender)	5 bundle	60 lineal ft.
10' x 16' (Solid Roof Extender)	7 bundle	70 lineal ft.

17 Installation of Optional Large Square Window (not included)

I.D.	Description	Size	CM	Qty.
----	Window			1
RI	Sill Plates	2 x 4 x 22-1/2"	57.1cm	2
DV	Vertical Trim	1 x 3 x 30-1/4"	76.9cm	2
DT	Horizontal Trim	1 x 3 x 28-3/4"	73.1cm	2
----	3" Nails, 2" Nails, 1-1/2" Finish Nails			

Determine location for optional window. Locating window opening is easiest when done from inside the building.

17 A. Arrange and attach part RI as shown. (from Large Square Window kit). Secure to frame using four 3" (6.7cm) nails.

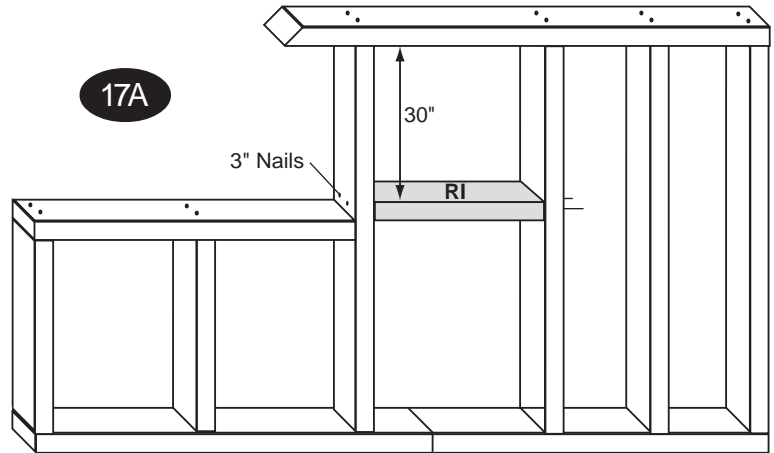

Inside of building

17 B. Drill 4 pilot holes in four corners of window opening. Window cutout size will be 22-1/2" wide by 30" tall. Cut window opening.

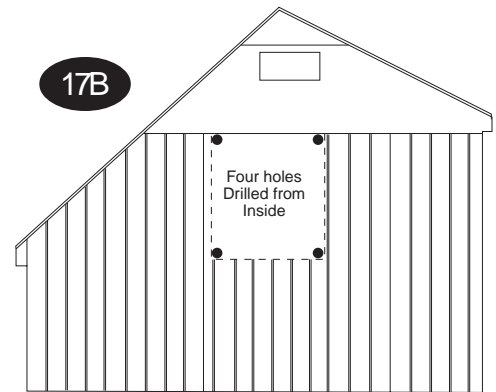

17 C. Level Window in opening and secure with four 2" (5cm) nails.

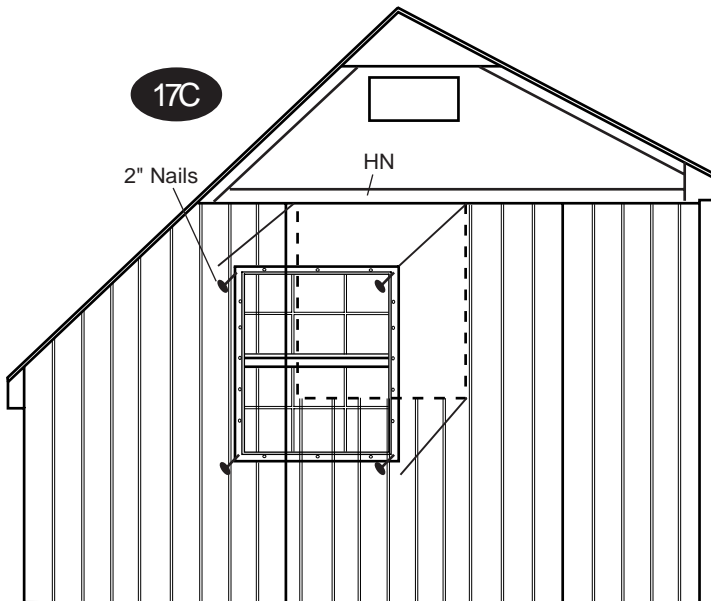

17 D. Attach Window Trim DV and DT as shown, using 1 1/2" (5cm) finish nails. Note: Top DV is not used for Solar Shed. Use the HN from main kit.

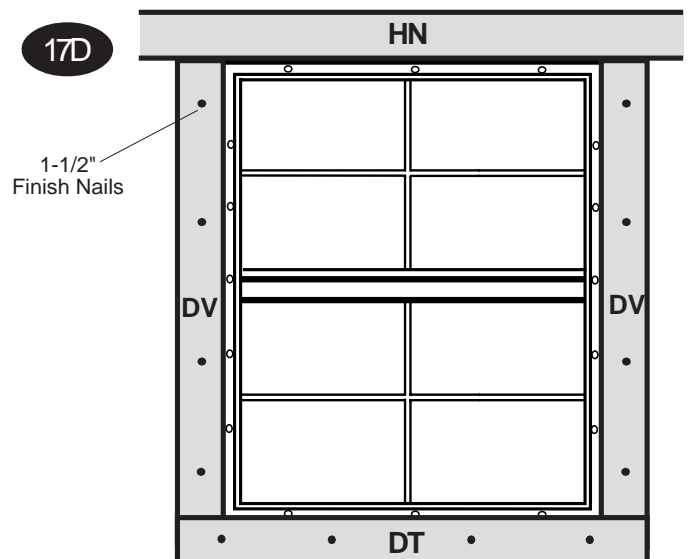

INSTALLING SHINGLES

Important: Make sure shingles overhang glass by approx. 3".

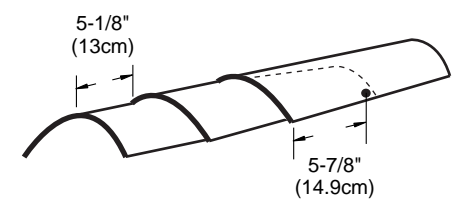
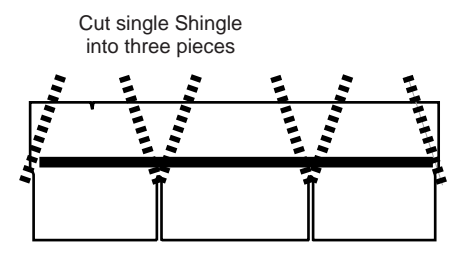
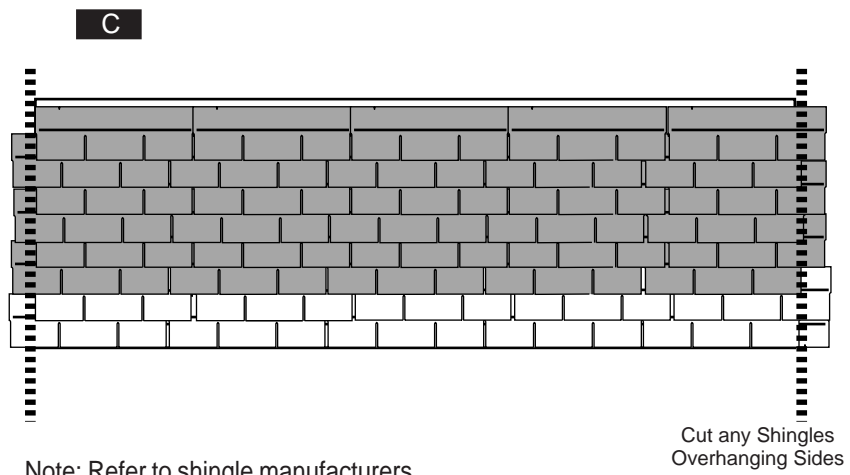
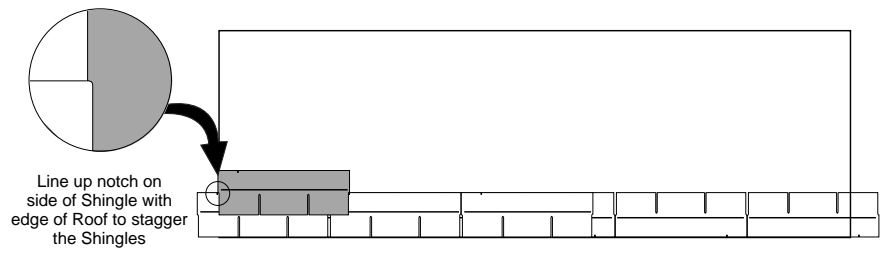
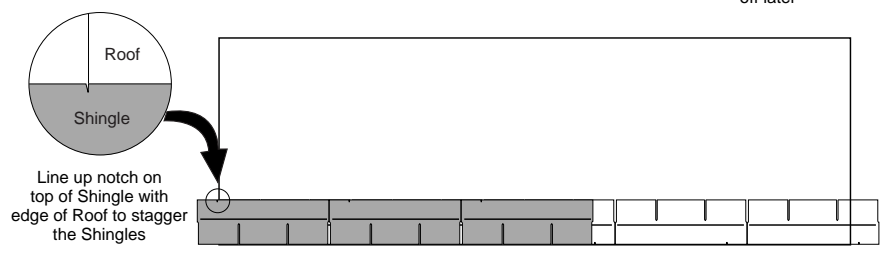
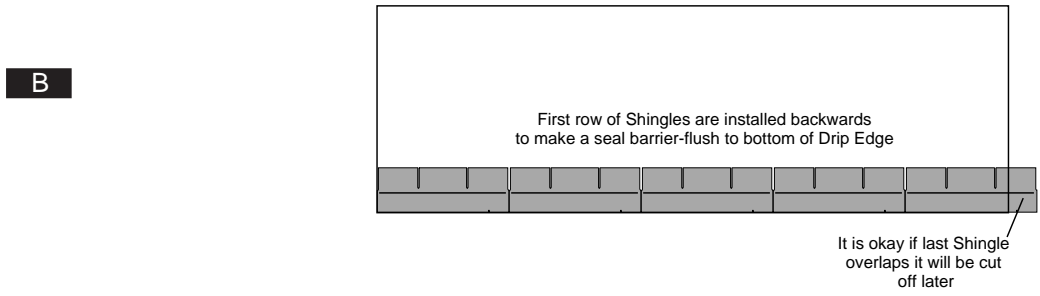
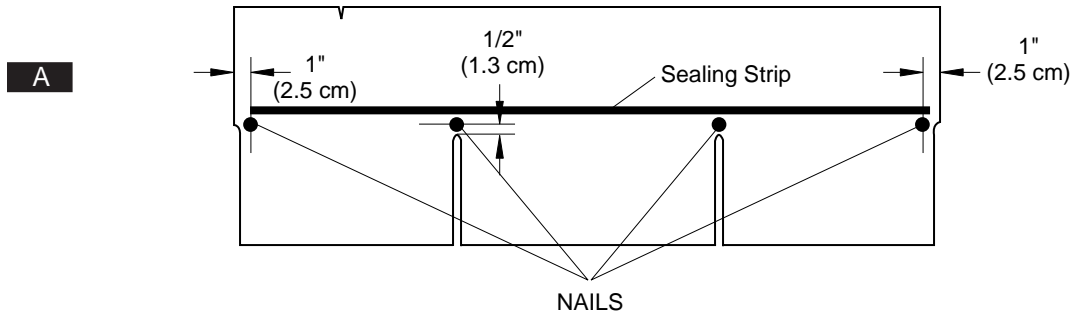

Note: Refer to shingle manufacturers instructions for further details.

Notes:

Notes:

Notes:

WARRANTY

Backyard Storage Solutions, LLC warrants the following:

1. Every product is warranted from defects in workmanship and manufacturing for one year.
2. All hardware and metal components are warranted for two years.
3. Trim is warranted for 10 years.
4. Waferboard siding and sheathing is warranted for two years.
5. SmartSide™ siding is warranted for 10 years on all Marco series buildings and 15 years on all Premier Series buildings.
6. Timber series buildings' siding and trim are warranted for 10 years.
7. Solar Shed windows are warranted for 1 year.
8. Cedar lumber is warranted for 15 years.
9. Cedar doors and Cedar Garden Center are warranted for 10 years.
10. Metal roof is warranted for 25 years.

**Limited Conditional
Warranty ***

Backyard Storage Solutions, LLC will repair, replace or pay for the affected part. In no event shall Backyard Storage Solutions, LLC pay the cost of labor or installation or any other costs related thereto. All warranties are from date of purchase. If a cash refund is paid on an affected part, it will be prorated from the date of purchase.

CONDITIONS

The warranty is effective only when:

1. The unit has been erected in accordance with the assembly instructions.
2. The unit has been properly shingled and painted or stained and regularly maintained thereafter.
3. The failure occurs when the unit is owned by the original purchaser.
4. Backyard Storage Solutions, LLC has received the warranty registration card within thirty (30) days of purchase and notification of the failure in writing within the warranty period specified above.
5. Backyard Storage Solutions, LLC has had reasonable opportunity during the sixty (60) days following receipt of notification to inspect and verify the failure prior to commencement of any repair work.

REQUIREMENTS

Storage Buildings & Playhouses

To validate your warranty, it is necessary to properly maintain your Backyard Storage Solutions, LLC unit; shingle the roof and paint or solid-colored stain the siding using 100% acrylic latex exterior product with a minimum of two (2) coats within sixty (60) days of assembly; caulk above all doors and all horizontal and vertical trim boards; paint and seal all exposed edges, sides and faces of SmartSide™ and waferboard siding to include all exterior walls and all sides and all edges of doors.

Gazebos, Pergolas & Timber Buildings

To validate your warranty, it is necessary to properly maintain your Backyard Storage Solutions, LLC unit. This includes treating all of the exposed cedar and pine surfaces on your gazebo or timber building with an exterior grade wood preservative, an exterior oil-based semi-transparent stain, an acrylic latex exterior paint or an acrylic latex solid color exterior stain within 30 days of assembly and as needed thereafter to maintain your warranty.

Keep vegetation trimmed away from building and make sure siding panels and trim do not come in contact with masonry or cement. The minimum ground clearance for siding must be one half inch (½ inch) from concrete slab or two and one half inches (2 ½") from the ground when building is erected or constructed on a treated wood floor kit. Water from sprinklers must be kept off unit. In no event will Backyard Storage Solutions, LLC be responsible for any indirect, incidental, consequential or special damages nor for failure(s) that are caused by events, acts or omissions beyond our control including, but not limited to, misuse or improper assembly, improper maintenance (which eventually leads to rot or decay) and acts of God. Backyard Storage Solutions, LLC will not be held responsible for any labor costs incurred to construct your unit. This warranty gives you certain specific rights that vary from state to state.

CLAIM PROCEDURE

To make a claim under this warranty, you can either call 1-888-827-9056 or prepare a letter. Please have ready the information below when you call or include the information when writing:

1. The model and size of the product.
2. A list of the part(s) for which the claim is made.
3. Proof of purchase of the Backyard Storage Solutions, LLC item, as shown on the original invoice.
4. Run code, as listed on the yellow warranty card enclosed in the product package.

Mail the above information to:

Backyard Storage Solutions, LLC
Attn: Customer Service
1000 Ternes
Monroe, MI 48162

***WARRANTY TERMS MAY VARY OUTSIDE THE U.S.A.**

IMPORTANT: This is your warranty certificate.

Please complete and mail your warranty card to properly validate your warranty.

ldr: 01/06/09

Backyard Storage Solutions, LLC le garantiza a Ud. que:

1. Cada producto no tiene defecto de mano de obra ni de manufactura por un período de un año.
2. La ferretería y los componentes de metal están garantizados por dos años.
3. La moldura está garantizada por 10 años.
4. La cobertura y el entablado están garantizados por dos años.
5. La cobertura SmartSide™ está garantizada por 10 años para los edificios Marco Series, y por 15 años para los edificios Premier Series.
6. La cobertura y la moldura de los edificios Timber Series están garantizadas por 10 años.
7. Las ventanas del Solar Shed están garantizadas por un año.
8. La madera de cedro está garantizada por 15 años.
9. Las puertas del cedro y el Centro de jardín del Cedro son justificados durante 10 años.
10. El techo del metal es justificado durante 25 años.

**Garantía Limitada
Condicionada ***

Backyard Storage Solutions, LLC reparará, cambiará o pagará por la pieza afectada. En ningún caso pagará Backyard Storage Solutions, LLC los gastos de instalación o trabajo manual, o cualesquiera otros gastos relacionados a eso.

Condiciones

Esta garantía es válida solo cuando:

1. La unidad ha sido construida según las instrucciones.
2. La unidad ha sido cubierta de tejas y pintada de manera correcta y mantenida regularmente.
3. El defecto ocurre mientras la unidad está en la posesión del comprador original.
4. Backyard Storage Solutions, LLC ha recibido la tarjeta de garantía del producto en el plazo de 30 (treinta) días después de comprar la unidad y después de la notificación del defecto por escrito, durante el período de vigencia de la garantía especificada arriba.
5. Backyard Storage Solutions, LLC ha tenido una oportunidad razonable, durante los sesenta (60) días después de haber recibido la notificación, para inspeccionar y averiguar la falla o el defecto antes de comenzar cualquier reparación.

Requisitos

Cobertizos de almacenamiento y Casitas de niños

Para dar validez a la garantía, es necesario mantener bien su unidad de Backyard Storage Solutions, LLC: cubrir con tejas el techo, pintar la cobertura con un producto 100% de acrílico y de látex para exteriores, usando dos manos de pintura o tinte, como mínimo, en el plazo de sesenta (60) días después de la construcción; masille arriba de todas las puertas y todos los paneles de moldura horizontales y verticales; pinte y selle todos los bordes dispuestos al exterior, los lados y las fachadas de la cobertura SmartSide™ y plano, incluyendo todos los muros exteriores y los lados y bordes de las puertas.

Belvederes, Pergolas y Edificios de Madera

Para dar validez a la garantía, es necesario mantener bien su unidad. Eso incluye tratar con un preservativo todos los superficies de cedro y de pino dispuestos al exterior, usando una preservativo para madera, un tinte de aceite semitransparente para exteriores, pintura acrílica de látex para exteriores, o un tinte acrílico de látex de un solo color, en el plazo de treinta (30) días después de construir el edificio, y luego como sea necesario.

Mantenga corta toda clase de vegetación cerca del edificio y asegúrese que la cobertura y la moldura no toquen ninguna obra de albañería o el cemento. El margen mínimo entre el suelo y la cobertura debe de ser media pulgada (1/2"), con un base de concreto; dos pulgadas y media (2 1/2") cuando se construye el edificio sobre un base de madera (usando un equipo de madera tratada). No se deben usar rociadores cerca de la unidad. En ningún caso será responsable Backyard Storage Solutions, LLC de daños especiales, incidentales, consiguientes o indirectos, ni de fallas causadas por sucesos, hechos u omisiones fuera de nuestro control; eso incluye, pero no está limitado a: el misuso; la construcción incorrecta; cuidado incorrecto (el cual causa, eventualmente, la putrefacción o la descomposición) y acciones de la naturaleza. Backyard Storage Solutions, LLC no será responsable de ningún gasto de instalación incurrido durante la construcción de la unidad. Esta garantía le da a Ud. ciertos derechos específicos que varían de estado a estado.

Para hacer una reclamación:

Para hacer una reclamación baja esta garantía, llame al 1-888- 827-9056 o escriba una carta. Favor de tener la siguiente información al llamarnos, o incluirla al escribirnos:

1. El modelo y el tamaño del producto.
2. Una lista de las piezas por las cuales hace Ud. la reclamación.
3. Prueba de compra del producto, como se muestra en la factura original.
4. (Run code) escrita en la tarjeta amarilla de garantía incluida con el producto.

Envíe la información a:

Backyard Storage Solutions, LLC
Attn: Customer Service
1000 Ternes
Monroe, MI 48162
USA

***LAS CONDICIONES DE LA GARANTIA PUEDEN VARIAR FUERA DE ESTADOS UNIDOS**

IMPORTANTE: Esta página es su certificado de garantía.

Favor de llenar completamente y enviar la tarjeta de garantía para dar validez a la garantía.

ldr: 01/06/09