

— EST. 1987 —

REV DATE: 25/05/2012

AHB

HOME FURNITURE COLLECTIONS

ASSEMBLY INSTRUCTIONS

EMPIRE STOOL

LOOSELY ATTACH EACH SCREW UNTIL FRAME IS ASSEMBLED THEN TIGHTEN WHEN COMPLETE

1

STEP 1

Attach one side leg frame to seat frame by using bolts A, Lock Washers B, Flat Washers C, and Allen Wrench E. Do not tighten yet.

STEP 2



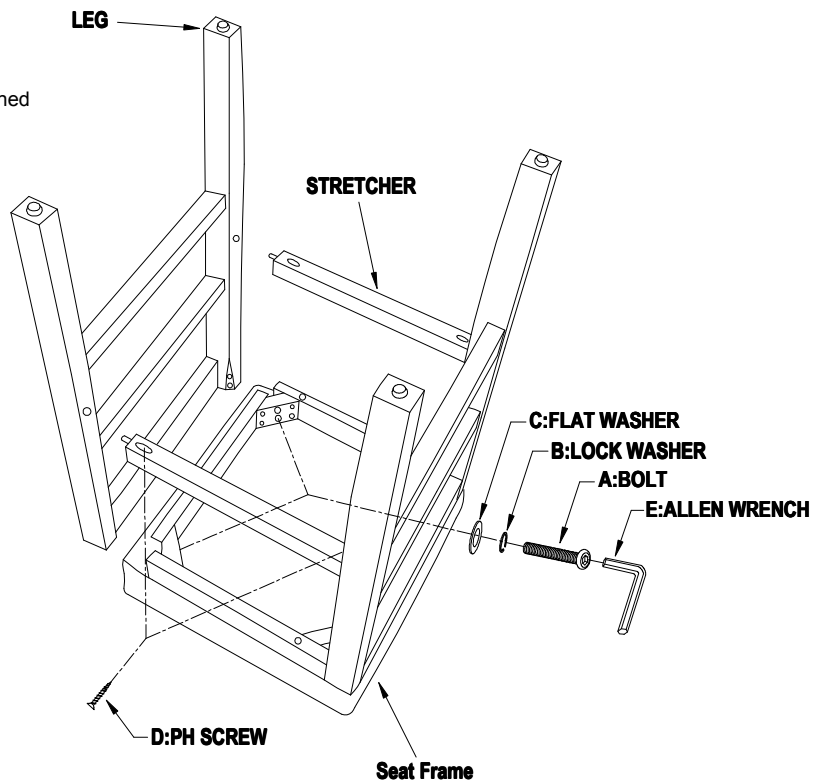

Assemble the stretchers to the attached leg frame with PH screws D.

STEP 3

Repeat step 1,2 for the other leg frame. Tighten all bolts now.



* PLEASE READ INSTRUCTION PRINTED ON SWIVEL PLATE
HARDWARE PACK
CHECK THAT THE FOLLOWING PARTS ARE IN CARTON

PARTS LIST				
A		BOLT	1/4"*2-1/4"	8PCS
B		LOCK WASHER	1/4"	8PCS
C		FLAT WASHER	1/4"*16mm	8PCS
D		PH SCREW	#8*1-1/2"L	4PC
E		ALLEN WRENCH	4mm	1PC

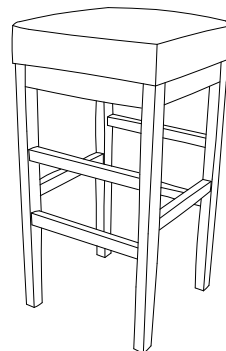

MADE IN CHINA