



Magnetic Dry-Erase Front Projection Screen  
**Insta-DEM Screen Series**

User's Guide



# Parts List for the Insta-DEM Screen

Please make sure all parts listed below are included before proceeding with the installation.

a.



b.

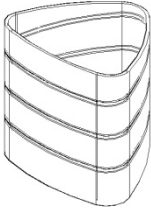

c.



d.

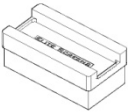

e.

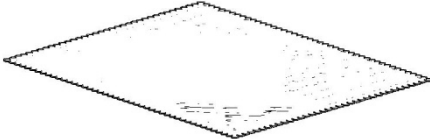

Parts List	QTY
a. Insta-DEM Screen Material	1
b. Pen Holder	1
c. Whiteboard markers	3
d. Elite special high density eraser	2
e. Microfiber cleaning cloth	1

## Notes:

1. For Best results and maximum product longevity, ALWAYS and ONLY use Elite Screens High Density Whiteboard Eraser.
2. Please use the microfiber cloth and clean water to cleanse the surface every 2-4 weeks to maintain a fresh and clean projection surface.

# Installation

**NOTE:** Prolonged storage of the Insta-DEM in its factory packaging may result in the material not being able to lie flat once removed from its tube. An easy way to remedy this is to remove the material from the tube and roll it up in a reverse manner for 5 minutes. This will flatten out the material and make it more pliable to work with.

1. Clean the magnetic surface location where the Insta-DEM Screen will be installed.
2. Measure and mark the top-right and bottom-right corner of the installation location.

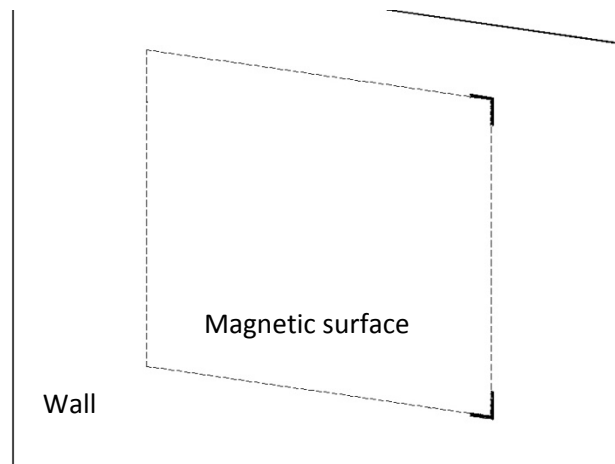

3. Attach the Insta-DEM Screen to the top-right and bottom-right corner of the installation location.

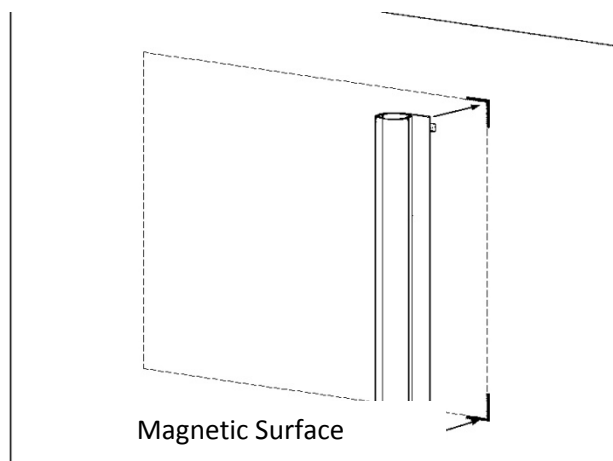

4. Carefully unroll the material and firmly attach the top and bottom until the Insta-DEM Screen is completely attached.

# Insta-DEM Dimension Table

Unit : mm				
Model	Nominal Diagonal	View Height (A)	View Width (B)	Thickness (C)
iWB52VWM	52"(4:3)	788	1050	0.65
iWB70VWM	70"(4:3)	1050	1422	0.65
iWB78XWM	78"(16:10)	1050	1680	0.65
iWB85HWM	85"(16:9)	1050	1866	0.65
Unit : inch				
Model	Nominal Diagonal	View Height (A)	View Width (B)	Thickness (C)
iWB52VWM	52"(4:3)	31.0	41.3	0.0255
iWB70VWM	70"(4:3)	42.0	56.0	0.0255
iWB78XWM	78"(16:10)	41.3	66.1	0.0255
iWB85HWM	85"(16:9)	41.3	73.5	0.0255

Measurements are intended as a reference only and are subject to change without notice. NOTE: Data Error may be ±1"

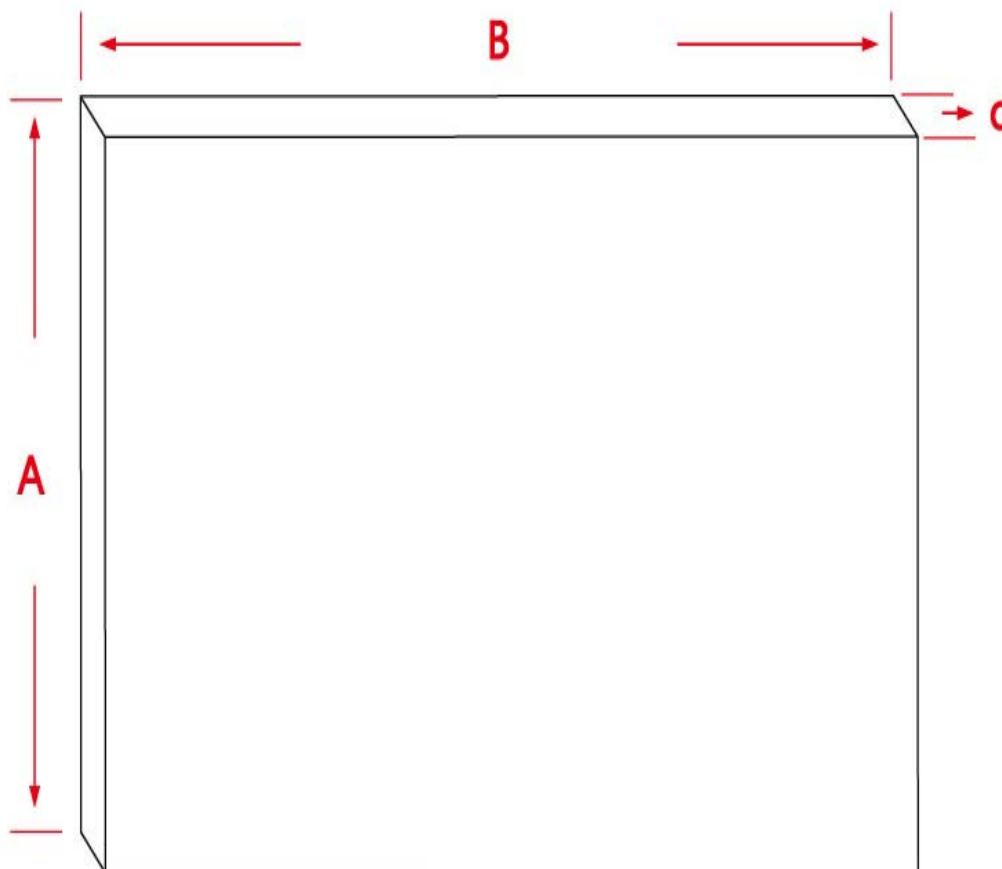

# Warranty Policy

- **Two (2) Year** parts and labor warranty from defects in workmanship from purchase date as follows (except for refurbished units as specified below).
- **Three (3) Year** parts and labor warranty from defects in workmanship for **GEMR** (Government, Educational, Military, & Religious) purchases of new product only.
- **Refurbished Units** carry a **90-DAY** parts and labor warranty.
- Each party will be responsible for one way shipping during the warranty period.
- A **RMA (Return Merchandise Authorization) number** must be issued in order to process a replacement or to authorize a return for warranty repair. Elite Screens will, at its sole option replace or repair the defective unit with a replacement \*(see exceptions below) after the defective unit or parts have been received. Once the product is received, Elite Screens will send out a replacement \*unit to the customer by ground service (subject to inventory availability).
- **Do Not Return Any Unauthorized Items to Elite Screens, as they will be refused and returned at your expense. The RMA Number must be included on the outside label of your shipping box. Our warehouse is not authorized to accept returns without an RMA number on the shipping label.**
- **RMA Numbers are valid for 45 days from the date issued.**
- **Missing Parts** must be reported within 7 days of receipt. If reported after 7 days, the customer will be responsible for shipping and handling fees. If reported after 30 days of receipt, the customer will be responsible for cost of parts and shipping & handling fees.

\*A New or refurbished replacement will be send out to the customer depending on the type of purchase (new or refurbished) and based on stock availability.

## **North America only U.S. and Canada**

For Warranty and Service requests, please submit an RMA/Service Form at:  
[www.elitescreens.com/warrantysupportform](http://www.elitescreens.com/warrantysupportform)

Please visit this link for full Warranty information:  
[www.elitescreens.com/warranty](http://www.elitescreens.com/warranty)

For Customer Service and Technical questions, please contact Elite Screens at:  
Telephone: (877) 511-1211 [service@elitescreens.com](mailto:service@elitescreens.com)  
Fax: (562) 926-8433 [techsupport@elitescreens.com](mailto:techsupport@elitescreens.com)

REMEMBER TO REGISTER YOUR PRODUCT AT:  
[WWW.ELITESCREENS.COM](http://WWW.ELITESCREENS.COM)

# Contact Info

US & Canada Tech Support & Warranty Claim

Please contact us at [service@elitescreens.com](mailto:service@elitescreens.com) or call +1 877-511-1211 #3 or fax +1-562-926-8433

Europe Tech Support & Warranty Claim

Please contact us at [service@elitescreens.eu](mailto:service@elitescreens.eu) or call +49-(0) 40-30392958

Asia Tech Support & Warranty Claim

Please contact us at [service@elitescreens.com.cn](mailto:service@elitescreens.com.cn) or call +86-(0) 755-8461-7989

Taiwan Tech Support & Warranty Claim

Please contact us at [service@elitescreens.com.tw](mailto:service@elitescreens.com.tw) or call +866+2+8990-1999

## America:

### Elite Screens Inc

16410 Manning Way  
Cerritos, CA 90703 USA  
Tel: +1-877-511-1211  
Fax: +1-562-926-8433  
[info@elitescreens.com](mailto:info@elitescreens.com)  
[www.elitescreens.com](http://www.elitescreens.com)

## Europe:

### Elite Screens Europe

Lübecker Straße 1  
22087 Hamburg, Germany  
Tel: +49-4030392494  
Fax: +49-40-49219200  
[info@elitescreens.eu](mailto:info@elitescreens.eu)  
[www.elitescreens.eu](http://www.elitescreens.eu)

## Asia:

### Elite Screens China Corp.

Longxi Duimianling Industry Zone  
Longcheng Longgang District,  
ShenZhen GuangDong, China  
Tel: +86-(0)755-8461-7989  
Fax: +86-(0)755-8461-7669  
[info@elitescreens.com.cn](mailto:info@elitescreens.com.cn)  
[www.elitescreens.com.cn](http://www.elitescreens.com.cn)

## Elite Screens France S.A.S

11, Allée William Penn  
92150 Suresnes, France  
Tel: +33-1-45064735  
Fax: +33-1-45064735  
[info.fr@elitescreens.com](mailto:info.fr@elitescreens.com)  
[www.elitescreens.com/fr](http://www.elitescreens.com/fr)

## Taiwan:

### Elite Screens Taiwan Corp.

4F., No. 42-1 Wuguan Rd. Wugu Township Taipei  
County 248, Taiwan (Wugu Industrial Park)  
Taiwan (R.O.C)  
Tel: +886+2+8990-1999  
Fax: +886+2+8990+1366  
[info@elitescreens.com.tw](mailto:info@elitescreens.com.tw)  
[www.elitescreens.com.tw](http://www.elitescreens.com.tw)

## Latin America Contact:

[info.la@elitescreens.com](mailto:info.la@elitescreens.com)

## East Asia Contact:

[info.ea@elitescreens.com](mailto:info.ea@elitescreens.com)

## India Contact

[info.india@elitescreens.com](mailto:info.india@elitescreens.com)

## Japan Contact:

[info.japan@elitescreens.com](mailto:info.japan@elitescreens.com)