

# KETTLER

## Montageanleitung „Giro GT“

Art.-Nr. 07639-500

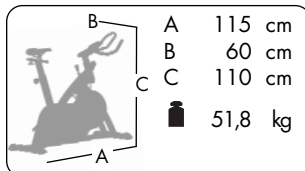

D

GB

CZ

SK

H

SLO

HR

RO

BG

SRB

GR

Der Umwelt zuliebe: wir drucken auf 100% Altpapier!

Abb. ähnlich



**Before assembling or using the exercise cycle, please read the following instructions carefully. They contain important information for use and maintenance of the equipment as well as for your personal safety. Keep these instructions in a safe place for maintenance purposes or for ordering spare parts.**

## For Your Safety

- ⚠ **RISK!** While assembly of the product keep off children's reach (Choking hazard - contains small parts).
- ⚠ **RISK!** Instruct persons using the equipment (in particular children) on possible sources of danger during exercising.
- ⚠ **RISK!** **Heart rate monitoring systems can be imprecise. Excessive training may lead to serious health damage or death. If you feel giddy or weak, please stop the training immediately.**
- ⚠ **WARNING!** Exercise should be used only for its intended purpose, i.e. for physical exercise by adult persons.
- ⚠ **WARNING!** Any other use of the equipment is prohibited and may be dangerous. The manufacturer cannot be held liable for damage or injury caused by improper use of the equipment.
- ⚠ **WARNING!** After your training by all means turn the turning handle for brake adjustment back to zero position in order to avoid heat influences on brake linings and disk flywheel. Pay attention to the fact that the quickly rotating disk flywheel strongly heats during operation.
- ⚠ **WARNING!** Before beginning your program of training, study the instructions for training carefully.
- ⚠ **WARNING!** All electric appliances emit electromagnetic radiation when in operation. Please do not leave especially radiation-intensive appliances (e.g. mobile telephones) directly next to the cockpit or the electronic control system as otherwise values displayed might be distorted (e.g. pulse measurement).
- Exercise has been designed in accordance with the latest standards of safety. Any features which may have been a possible cause of injury have been avoided or made as safe as possible.
- Incorrect repairs and structural modifications (e.g. removal or replacement of original parts) may endanger the safety of the user.
- Damaged components may endanger your safety or reduce the lifetime of the equipment. For this reason, worn or damaged parts should be replaced immediately and the equipment taken out of use until this has been done. Use only original KETTLER spare parts.
- If the equipment is in regular use, check all its components thoroughly every 1-2 months. Pay particular attention to the tightness of bolts and nuts. This applies especially to the securing bolts for saddle and handlebars.
- To ensure that the safety level is kept to the highest possible standard, determined by its construction, this product should be serviced regularly (once a year) by specialist retailers.
- Before beginning your program of exercise, consult your doctor to ensure that you are fit enough to use the equipment. **Base your program of exercise on the advice given by your doctor. Incorrect or excessive exercise may damage your health!**
- **Any interference with parts of the product that are not described within the manual may cause damage, or endanger the person using this machine. Extensive repairs must only be carried out by KETTLER service staff or qualified personnel trained by KETTLER.**
- In case of enquiry, please contact your KETTLER dealer.
- In choosing the location of the apparatus, ensure a sufficient safety distance from any obstacles. The apparatus must not be mounted in the immediate vicinity of main passageways (paths, doorways, corridors).
- For a comfortable training position please adjust the handlebar and saddle position to your body height.
- When mounting the product please take the recommended torque information into account ( $M = xx \text{ Nm}$ ).
- The exercise cycle complies with the DIN EN 957 - 1/- 5 class HC. It is therefore unsuitable for therapeutic use.

## Handling the equipment

- ⚠ **ATTENTION!** It is not recommended to use or store the apparatus in a damp room as this may cause it to rust. The friction surface of the flywheel is especially sensitive to the formation of rust. Should this occur (e.g. after a prolonged period of disuse) the rust should be removed using sandpaper or steel wool. Do not use grease or oil! Please ensure that no part of the machine comes in contact with liquids (drinks, perspiration etc.). This may cause corrosion.
- Before using the equipment for exercise, check carefully to ensure that it has been correctly assembled.
- Before beginning your first training session, familiarize yourself thoroughly with all the functions and settings of the unit.
- The machine is designed for use by adults and children should not be allowed to play with it. Children at play behave unpredictably and dangerous situations may occur for which the manufacturer cannot be held liable. If, in spite of this, children are allowed to use the equipment, ensure that they are instructed in its proper use and supervised accordingly.
- A slight production of noise at the bearing of the centrifugal mass is due to the construction and has no negative effect upon operation. Possibly occurring noise during reverse pedalling results from engineering and are absolutely safe.
- Use for your regular cleaning, maintenance and care our appliance maintenance set (Article no. 07921-000) specifically licensed for KETTLER Sports apparatus and available from the Sport specialized trade.
- After your training by all means turn the turning handle for brake adjustment back to zero position in order to avoid heat influences on brake linings and disk flywheel.

- To operate correctly, the pulse function requires a minimum voltage of 2,7 volts (only for computers working with batteries).
- The equipment is dependent of revolutions per minute.
- **Please ensure that liquids or perspiration never enter the machine or the electronics.**
- Before use, always check all screws and plug-in connections as well as respective safety devices fit correctly.
- The brake linings should also be checked at regular intervals and adjusted as necessary.
- Always wear suitable shoes when using.

- Nobody may be in the moving range of a training person during training.

**⚠ Attention!** Due to a special lacquer which ensures a high level of durability of the generator and the flywheel, an odour may develop during your first training units with your new home sports equipment. However, the odour will disappear after several training units.

Please excuse us for the odour. We hope you will enjoy your training with your new KETTLER home sports equipment.

## Instructions for Assembly

**⚠ RISK!** Ensure that your working area is free of possible sources of danger, for example don't leave any tools lying around. Always dispose packaging material in such a way that it may not cause any danger. There is always a **risk of suffocation** if children play with plastic bags!

- Ensure that you have received all the parts required (see check list) and that they are undamaged. Should you have any cause for complaint, please contact your KETTLER dealer.
- Before assembling the equipment, study the drawings carefully and carry out the operations in the order shown by the diagrams. The correct sequence is given in capital letters.
- The equipment must be assembled with due care by an adult person. If in doubt call upon the help of a second person, if possible technically talented.
- Please note that there is **always** a danger of injury when working with tools or doing manual work. Therefore please be careful when assembling this machine.

- The fastening material required for each assembly step is shown in the diagram inset. Use the fastening material exactly as instructed. The required tools are supplied with the equipment.
- Bolt all the parts together loosely at first, and check that they have been assembled correctly. Tighten the locknuts by hand until resistance is felt, **then use spanner to finally tighten nuts completely against resistance (locking device)**. Then check that all screw connections have been tightened firmly. **Attention:** once locknuts have been unscrewed they no longer function correctly (the locking device is destroyed), and must be replaced.
- For technical reasons, we reserve the right to carry out preliminary assembly work (e.g. addition of tubing plugs).

## List of spare parts page 28-29

When ordering spare parts, always state the full article number, spare-partnumber, the quantity required and the S/N of the product (see handling).

**Example order:** Art.no.07639-500 / spare-part no. 68008204 / 1 pieces / S/N .....

Please keep original packaging of this article, so that it may be used for transport at a later date, if necessary.

Goods may **only** be returned after prior arrangement and in (internal) packaging, which is safe for transportation, in the original box if possible.

It is important to provide a detailed defect description / damage report!

**Important:** spare part prices do not include fastening material; if fastening material (bolts, nuts, washers etc.) is required, this should be clearly stated on the order by adding the words „**with fastening material**“.

## Waste Disposal

KETTLER products are recyclable. At the end of its useful life please dispose of this article correctly and safely (local refuse sites).

### **GB** KETTLER GB Ltd.

Kettler House, Merse Road

North Moons Moat

Redditch, Worcestershire B98 9HL

☎ +44 1527 591901

✉ +44 1527 62423

[www.kettler.co.uk](http://www.kettler.co.uk)

Mail: [sales@kettler.co.uk](mailto:sales@kettler.co.uk)

### **USA** KETTLER International Inc.

1355 London Bridge Road

Virginia Beach, VA 23453

[www.kettlerusa.com](http://www.kettlerusa.com)



☎ +1 888 253 8853



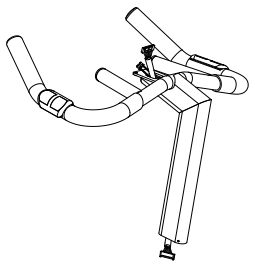
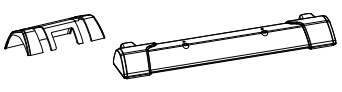

✉ +1 888 222 9333

## Checkliste (Packungsinhalt)

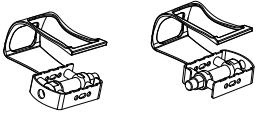
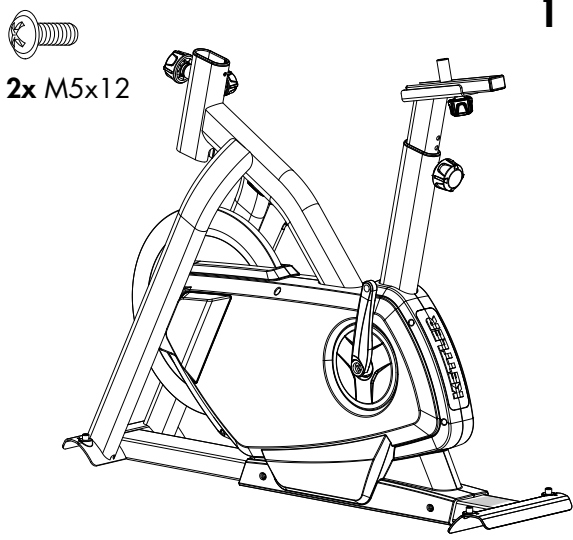

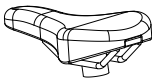
- GB - Checklist (contents of packaging)
- CZ - Kontrolní seznam (obsah balení)
- SK - Kontrolný zoznam (obsah balenia)
- H - (Csomagolás tartalmának) ellenőrző listája
- SLO - Kontrolni seznam (vsebina embalaže)

- HR - Kontrolni popis (sadržaj pakovanja)
- RO - Lista de verificare (conținutul pachetului)
- BG - Списък за проверка (съдържание на опаковката)
- SRB - Ček-lista (sadržaj pakovanja)
- GR - Κατάλογος ελέγχου (περιεχόμενο συσκευασίας)

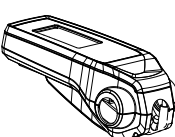
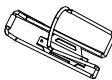
|  |              |
|--|--------------|
|               | <b>Stck.</b> |
|  | <b>1</b>     |
|               | <b>1</b>     |
|               | <b>1</b>     |
|              | <b>1/1</b>   |
| <br>2x M5x12 | <b>1</b>     |

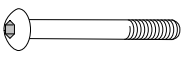

|  |          |
|--|----------|
|   | <b>1</b> |
|  <br><b>4x 3x8</b> <b>4x M5x10</b> | <b>1</b> |
| <br><b>4x 3x20</b>   |          |
|   | <b>1</b> |
|   | <b>1</b> |

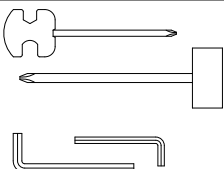
**29**  **Pos. 28**

|  |        |          |
|--|--------|----------|
|  | M 8x60 | <b>4</b> |
|  | M 5x12 | <b>4</b> |
|  | ø 8/19 | <b>4</b> |
|  |        | <b>1</b> |

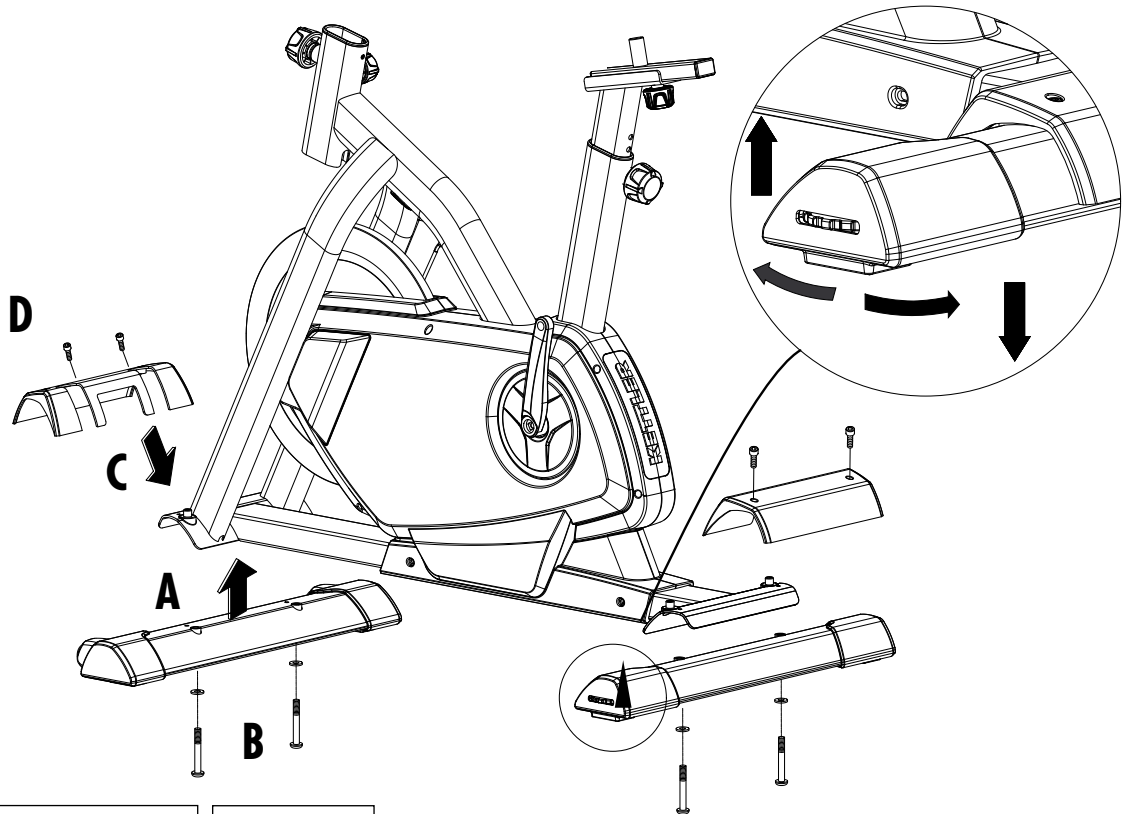
1

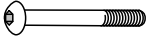

**B**    
4x M 8x60 = 15 Nm Ø 8x19

**D**   
4x M5x12

2

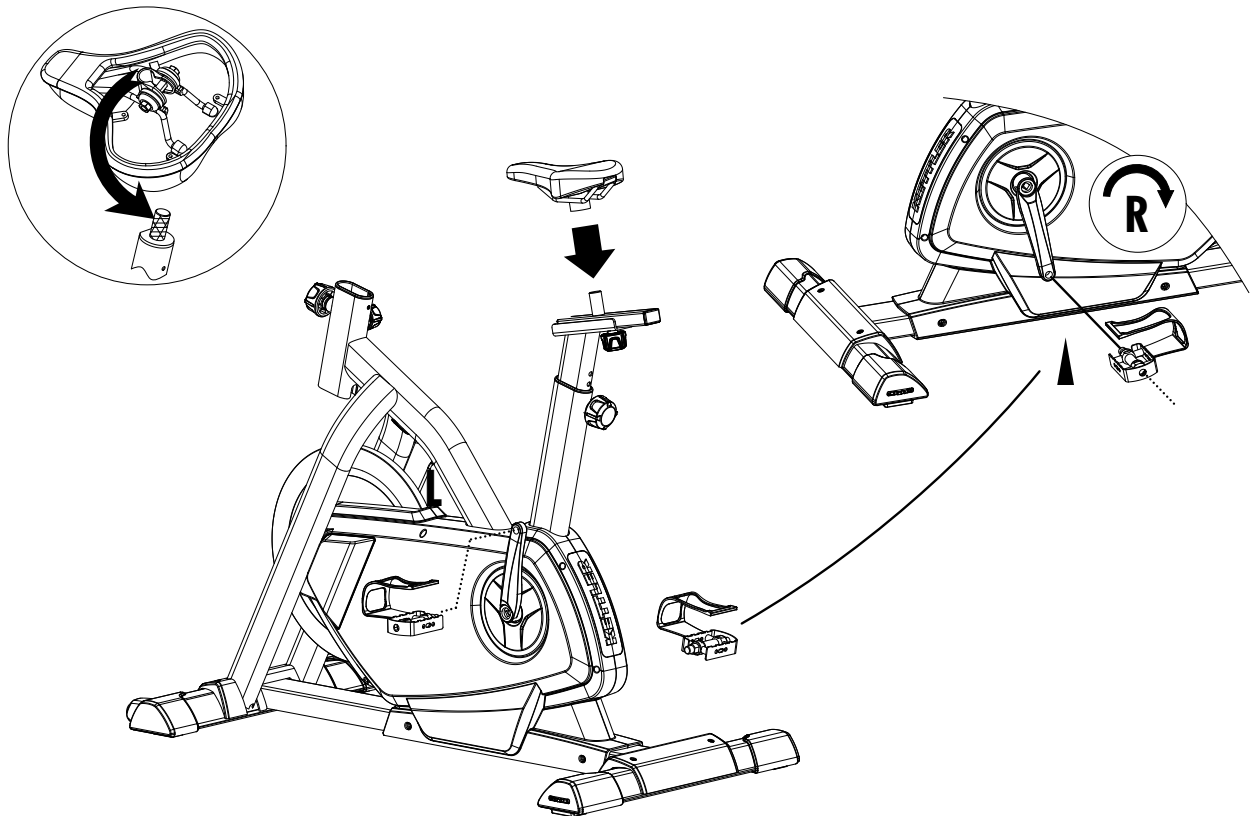
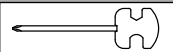

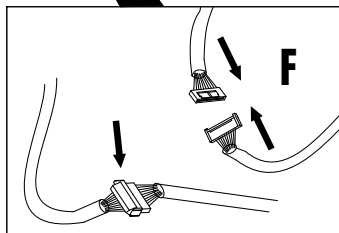
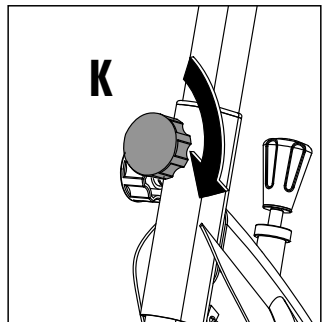
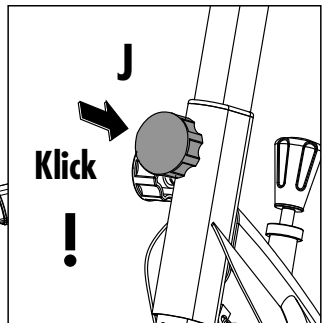
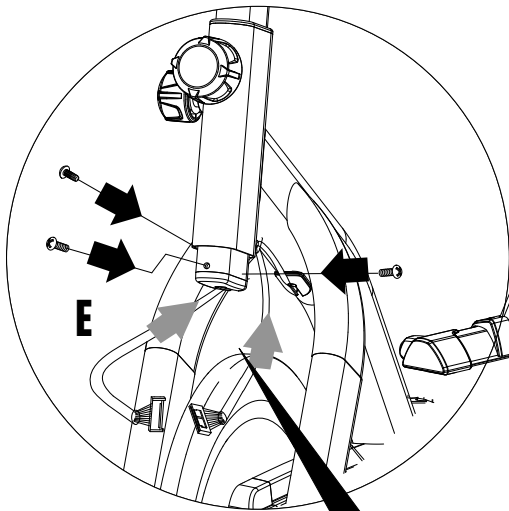
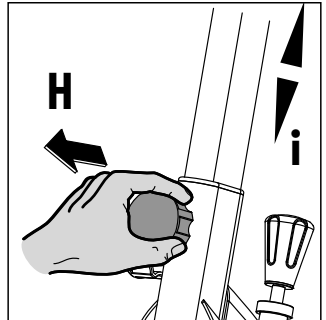
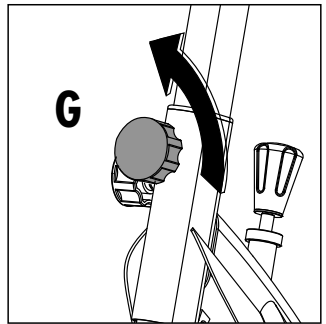
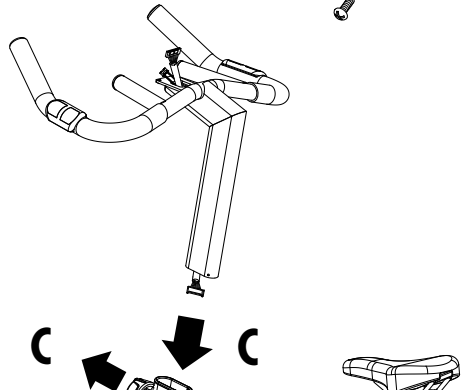
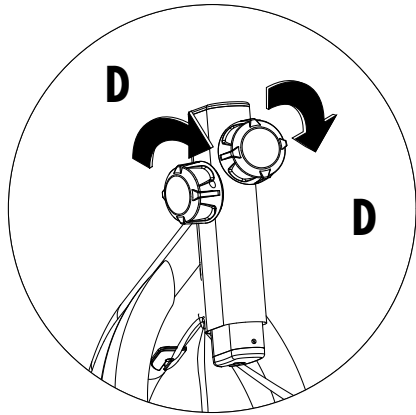
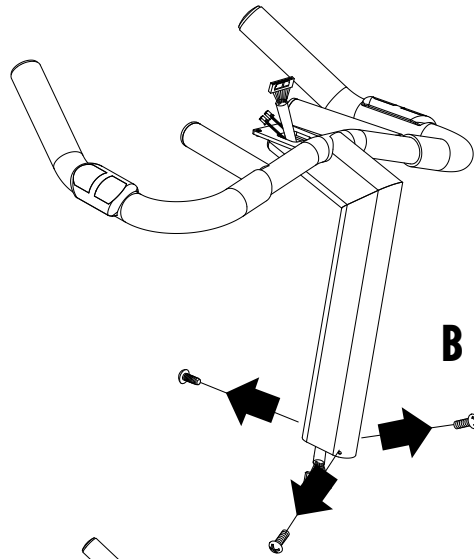
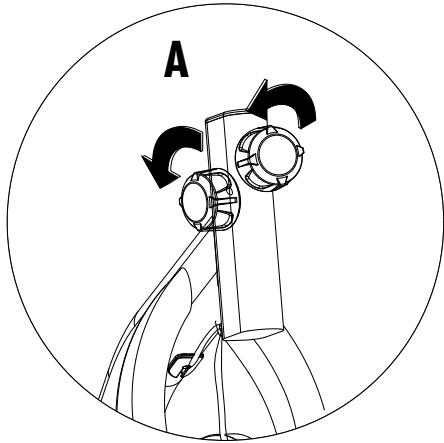
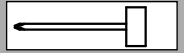

**B/E**   
**3x** M 3x12

4

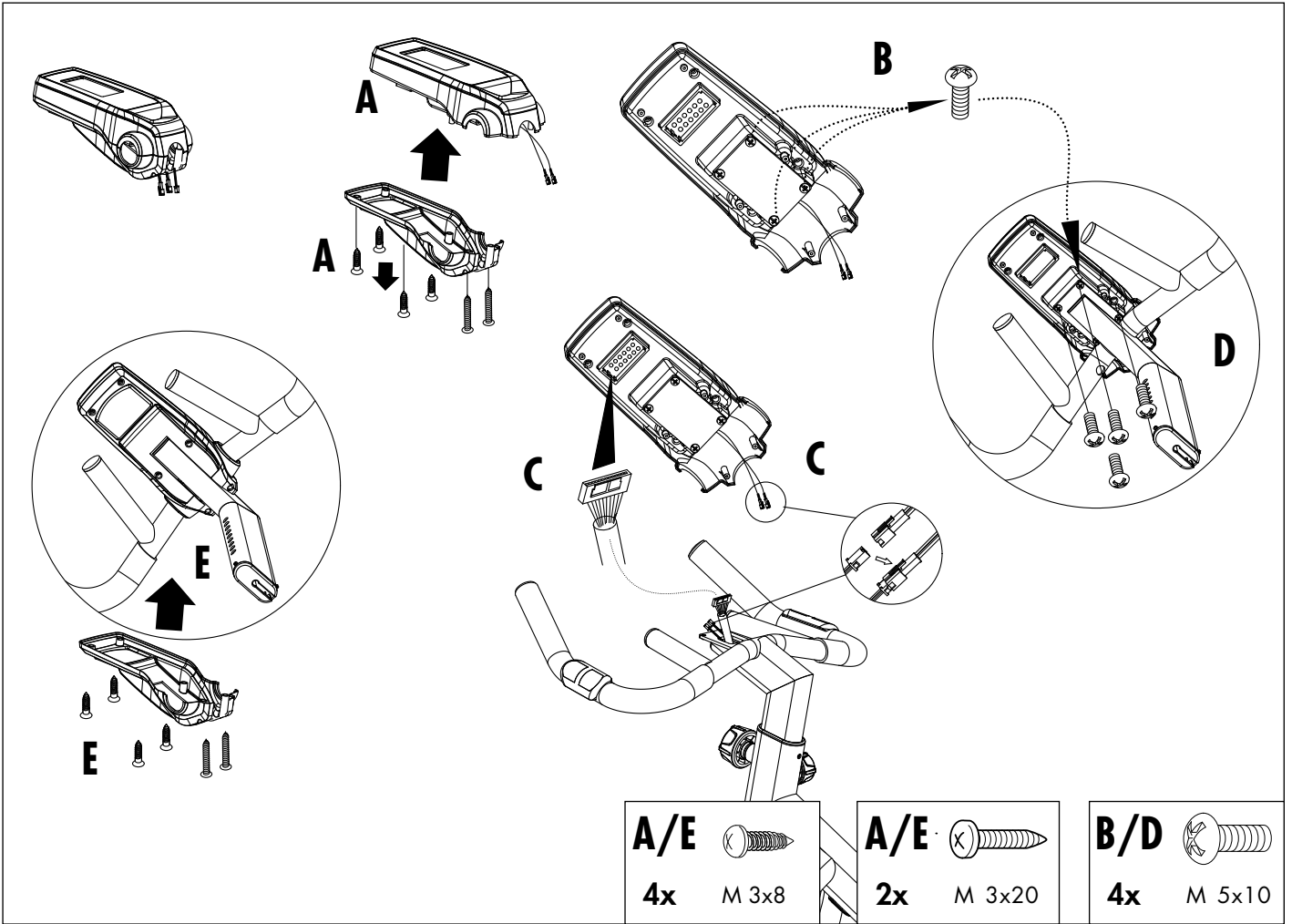
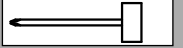

5

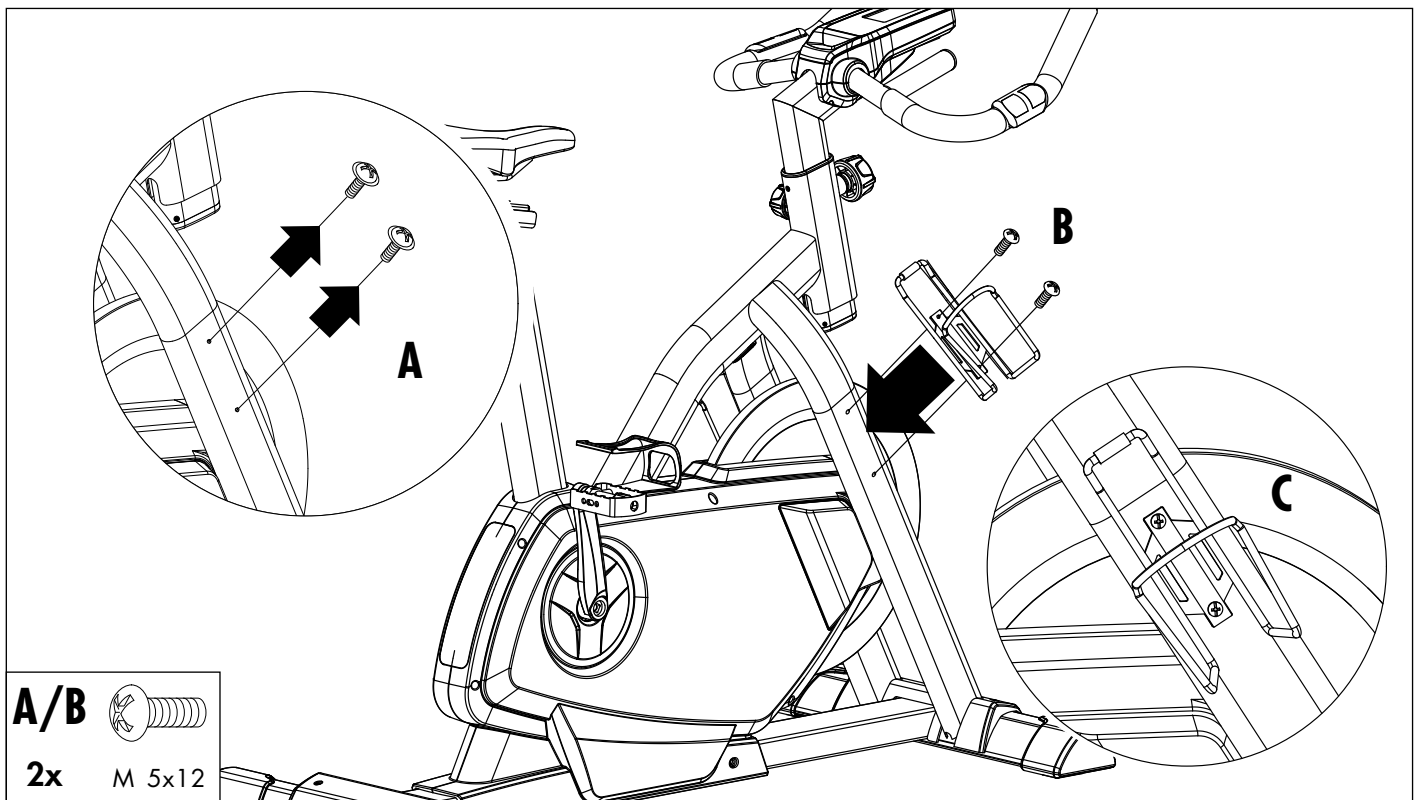
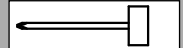

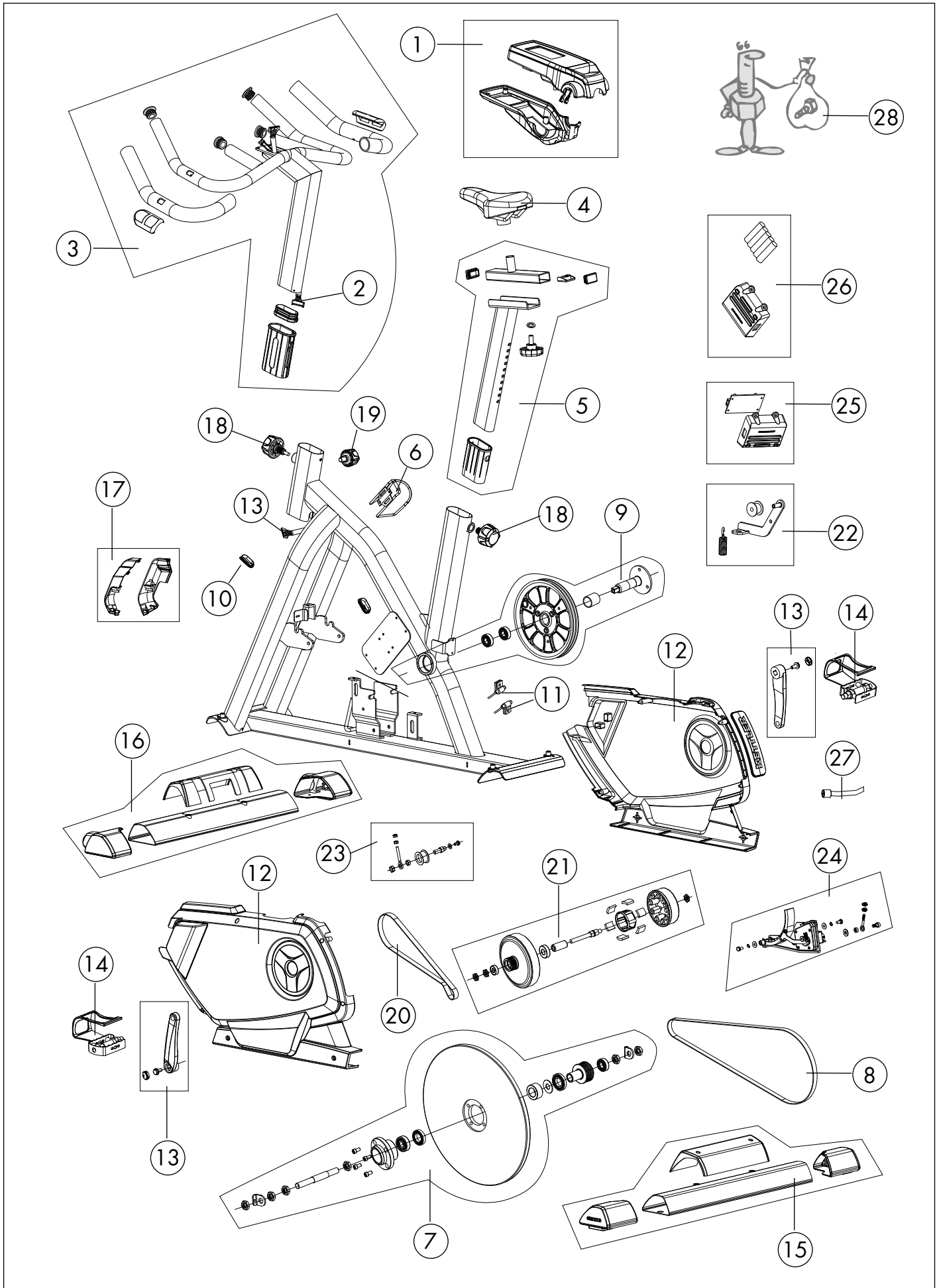



## Ersatzteilbestellung

- GB - Spare parts order
- CZ - Objednání náhradních dílů
- SK - Objednávania náhradných dielov
- H - Pótalkatrész rász
- SLO - Načrt nadomestnih delov

- HR - Načrt rezervnih dijelova
- RO - Comandarea pieselor de schimb
- BG - Резервни части за
- SRB - Naručivanje rezervnih delova
- GR - Ανταλλακτικά για ανταλλακτικά

|   |    | 07639-500 |
|---|----|-----------|
| ① | 1x | 68008201  |
| ② | 1x | 68008021  |
| ③ | 1x | 68008203  |
| ④ | 1x | 68008204  |
| ⑤ | 1x | 68008205  |
| ⑥ | 1x | 68008006  |
| ⑦ | 1x | 68008024  |
| ⑧ | 1x | 68008010  |
| ⑨ | 1x | 68008210  |
| ⑩ | 2x | 68008019  |
| ⑪ | 1x | 68008012  |
| ⑫ | 1x | 68008215  |
| ⑬ | 1x | 68008014  |
| ⑭ | 1x | 68008015  |

|   |    | 07639-500 |
|---|----|-----------|
| ⑮ | 1x | 68008218  |
| ⑯ | 1x | 68008219  |
| ⑰ | 1x | 68008220  |
| ⑱ | 2x | 68008221  |
| ⑲ | 1x | 68008222  |
| ⑳ | 1x | 68008027  |
| ㉑ | 1x | 68008028  |
| ㉒ | 1x | 68008236  |
| ㉓ | 1x | 68008029  |
| ㉔ | 1x | 68008022  |
| ㉕ | 1x | 68008023  |
| ㉖ | 1x | 68008232  |
| ㉗ | 1x | 68008032  |
| ㉘ | 1x | 68008235  |

- D - Beispiel Typenschild - Seriennummer
- GB - Example Type label - Serial number
- CZ - Primer tipske ploščice - serijske številke
- SK - Príklad: Typový štítok - sériové číslo
- H - Például a készülék ismertető címkéjén található sorozatszám
- SLO - Primer tipske ploščice - serijske številke
- HR - Primjer tipske pločice - serijskog broja
- RO - Exemplu plăcuța de fabricație - seria
- BG - Пример типова табелка - сериен номер
- SRB - Primer tipske pločice - serijski broj
- GR - Παράδειγμα Πινακίδια τύπου - Αριθμός σειράς

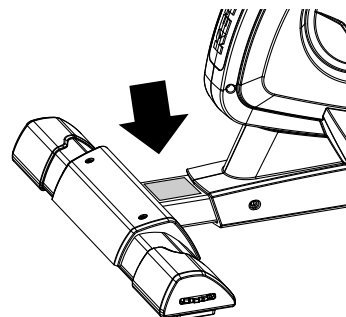

## Handhabungshinweise

- GB - Handling
- CZ - āPokyny k manipulaci
- SK - Pokyny k manipulácii
- H - Kezelési utasítások
- SLO - Napotki za ravnanje
- HR - Napomene o rukovanju
- RO - Indicații privind manipularea
- BG - Указания за работа
- SRB - Uputstvo za rukovanje
- GR - Υποδείξεις χειρισμού

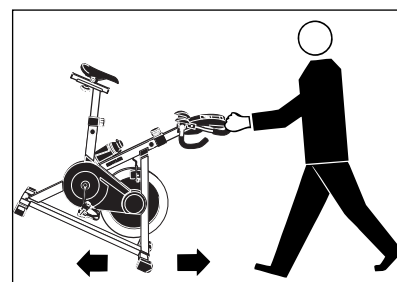







HEINZ KETTLER GmbH & Co. KG · Postfach 1020 · D-59463 Ense-Parsit  
[www.kettler.de](http://www.kettler.de)