

# OMNI

FR47201PNI

Bulbs: 60W G-9

Replacement Parts: SHADE: R47200GL, R47200BLSH

## ASSEMBLY INSTRUCTIONS

Assembly of this fixture will be accomplished attaching the mounting strap to the junction box, then making all necessary electrical connections, hanging the fixture from the ceiling and then installing the glass.

**SAFETY WARNING:** Read wiring and grounding instructions [FRIS 18] and any additional directions. Turn power supply off during installation. If new wiring is required, consult a qualified electrician or local authorities for code requirements.

### STEP 1

- 1 Prepare mounting strap (a) by threading the two longest screws (b) into the back of the mounting strap (a), making sure the holes into which the screws are threaded match the spacing of holes (d) in the backplate (e) - See Drawing 2.
- 2 Attach mounting strap (a) to junction box (j) using two screws (c).
- 3 Make electrical connections from supply wire to fixture lead wires. Refer to instruction sheet [FRIS18] and follow all instructions to make all necessary wiring connections. Then refer back to this sheet to continue installation of this fixture.
- 4 To mount fixture, slip the two mounting screws (b) through the two mounting holes (d) in the backplate (e).
- 5 While holding fixture in place, thread the two ball knobs (f) on to the end of the mounting screws (b), and tighten.

### STEP 2

**Note:** Fixture should be lamped accordingly at this point before proceeding.

- 1 To install glass slip glass (3) over socket (2) - see Drawing 2
- 2 Slip spacer (1) over socket (2).
- 3 Fixture can be lamped at this time with G-9 bulbs supplied.
- 4 Thread bulb shield (4) onto socket (2) and hand tighten only to secure glass.
- 5 Repeat for remaining pieces of glass.

[DRAWING 1]

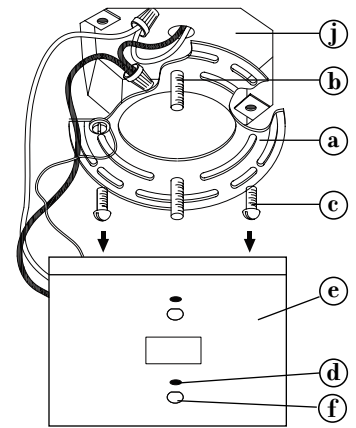

[DRAWING 2]

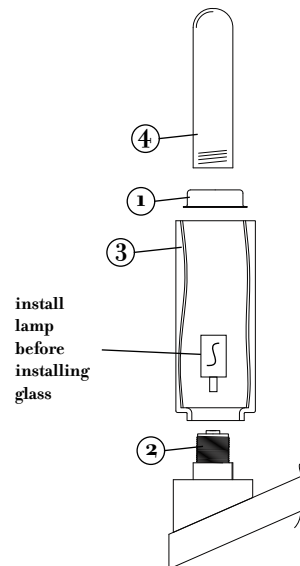

FREDRICK RAMOND  
ESTABLISHED 1965

800.421.3517 WWW.FREDRICKRAMOND.COM

01.01.12

# FRIS18

## WIRING AND GROUNDING INSTRUCTIONS

**SAFETY WARNING:** Read wiring and grounding instructions [FRIS 18] and any additional directions. Turn power supply off during installation. If new wiring is required, consult a qualified electrician or local authorities for code requirements.

### STEP 1 WIRING INSTRUCTIONS

#### Indoor Fixtures

- 1 Connect positive supply wire (a) (typically black or the smooth, unmarked side of the two-conductor cord) to positive fixture lead (b) with appropriately sized twist on connector - See Drawings 1 or 2.
- 2 Connect negative supply wire (c) (typically white or the ribbed, marked side of the two-conductor cord) to negative fixture lead (d).
- 3 Please refer to the grounding instructions below to complete all electrical connections.

#### Outdoor Fixtures

- 1 Connect positive supply wire (a) (typically black or the smooth unmarked side of the two-conductor cord) to positive fixture lead (b) with appropriately sized twist on connector - See Drawings 2 or 3.
- 2 Connect negative supply wire (c) (typically white or the ribbed, marked side of the two-conductor cord) to negative fixture lead (d).
- 3 Cover open end of connectors with silicone sealant to form a watertight seal.
  - If installing a wall mount fixture, use caulk to seal gaps between the fixture mounting plate (backplate) and the wall. This will help prevent water from entering the outlet box. If the wall surface is lap siding, use caulk and a fixture mounting platform specially.
- 4 Please refer to the grounding instructions below to complete all electrical connections.

[DRAWING 1]

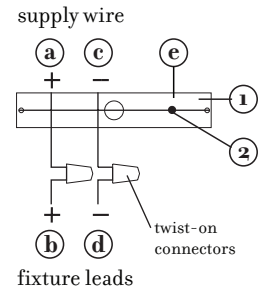

[DRAWING 2]

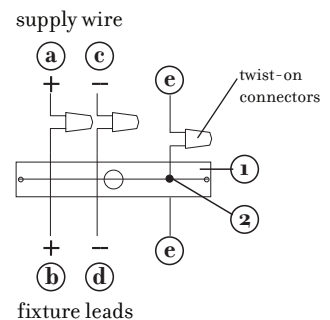

[DRAWING 3]

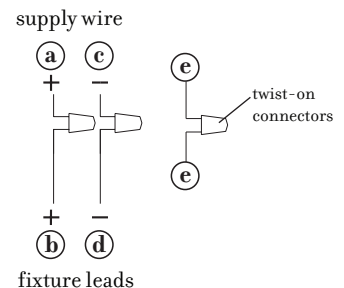

### STEP 2 GROUNDING INSTRUCTIONS

#### Flush Mount Fixtures

For positive grounding in a 3-wire electrical system, fasten the fixture ground wire (e) (typically copper or green plastic coated) to the fixture mounting strap (1) with the ground screw (2) - See Drawing 1.

Note: On straps for screw supported fixtures, first install the two mounting screws in strap.

Any remaining tapped hole may be used for the ground screw.

#### Chain Hung Fixtures

Loop fixture ground wire (e) (typically copper or green plastic coated) under the head of the ground screw (2) on fixture mounting strap (1) and connect to the loose end of the fixture ground wire directly to the ground wire of the building system with appropriately sized twist-on connectors - See Drawing 2.

#### Post-Mount Fixtures

Connect fixture ground wire (e) (typically copper or green plastic coated) to power supply ground with appropriately sized twist-on connector inside post. Cover open end of connector with silicone sealant to form a watertight seal - See Drawing 3.



FREDRICK RAMOND  
ESTABLISHED 1965