

BARCELONA



FR44102

Bulbs: 60W CAND. & 75W MED.

ASSEMBLY INSTRUCTIONS

Assembly of this fixture will be accomplished by first spreading the arms to their proper position, assembling the main body parts, hanging the fixture, installing the glass and then attaching the crystals.

SAFETY WARNING: Read wiring and grounding instructions [FRIS 18] and any additional directions. Turn power supply off during installation. If new wiring is required, consult a qualified electrician or local authorities for code requirements.

STEP 1

- 1 Take the main fixture assembly and spread the arms (a) until they are approximately 40° apart - See Drawing 1.

STEP 2 Refer to Hanging Instruction Sheet [FRIS19-50R] to hang fixture. Then refer back to this sheet to continue installation of this fixture.

STEP 3

- 1 Remove threaded socket ring (1) from socket (c) - See Drawing 2.
- 2 Slip small alabaster bowl (2) over socket (c).
- 3 Thread socket ring (1) onto socket (c) to secure glass (2).
 - The large natural alabaster bowls used on the Barcelona series can be scratched during installation if care is not taken. To prevent scratching of the alabaster, we suggest the following procedure.
- 4 Prior to inserting large bowl (3), take small hand towels and lay them over each of the arms - See Drawing 3.
- 5 Tilt alabaster bowl up and slip lip of glass under uprights, being careful not to damage the wires and quick connect (5) located in the bottom center of the fixture.

Note: Make sure quick connect is passed through the center hole (d) of the alabaster bowl (3) and the center hole also slips over the center pipe (e).
- 6 Plug quick connector (4) and (5) together.

Note: the connector is designed to fit only one way.
- 7 Fixture can now be lamped accordingly.

STEP 4

- 1 Remove the ball knob screws (6) located above the socket assembly (f) - See Drawing 2.
- 2 Talk half of the perforated diffuser (7) and attach it above socket assembly (f) using the ball knob screws (6) removed earlier.
- 3 Repeat steps 1-2 for opposite half of perforated diffuser (7), making sure the tabs are engaged on the opposite diffuser half.

STEP 5 Refer to Crystal Installation Sheet provided to install crystals.

[DRAWING 1]

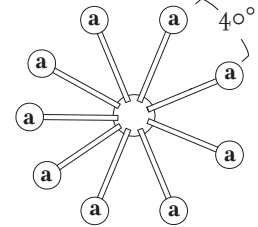

[DRAWING 2]

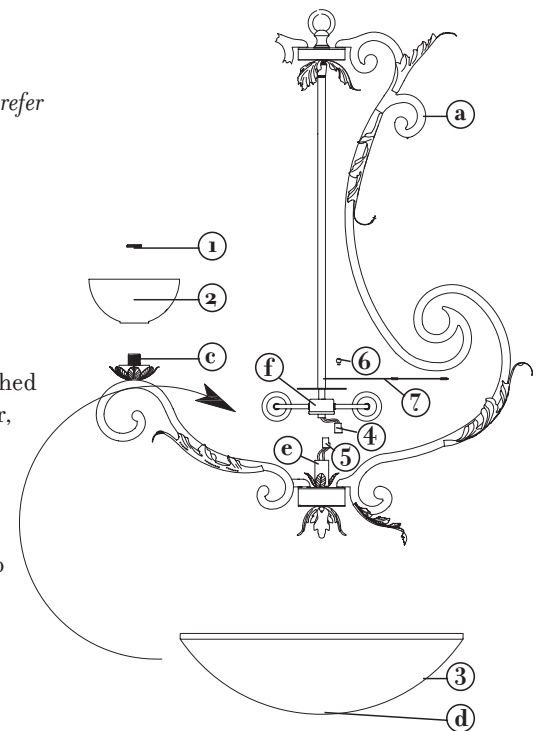

[DRAWING 3]

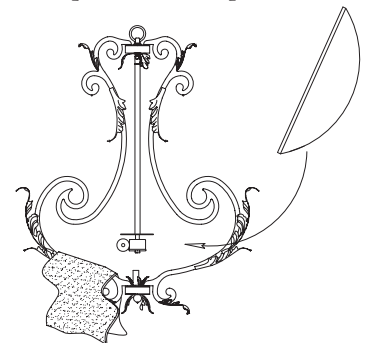

BARCELONA

FR44102



Bulbs: 75W MED. Replacement Parts:

CRYSTAL INSTALLATION INSTRUCTIONS

This Barcelona chandelier use 4 sizes of crystals pendalogueues.

STEP 1

- 1 Starting at the top of the fixture and working your way down, attach , medium pear shaped crystal (2) to eyelet (b).
- 2 Attach small pear shape crystal (1) to eyelet (a).
- 3 Attach large pear shaped crystal (3) to eyelet (c).
- 4 Attach large crystal ball (4) to eyelet (d).
- 5 Repeat steps 1-4 for remaining arms.

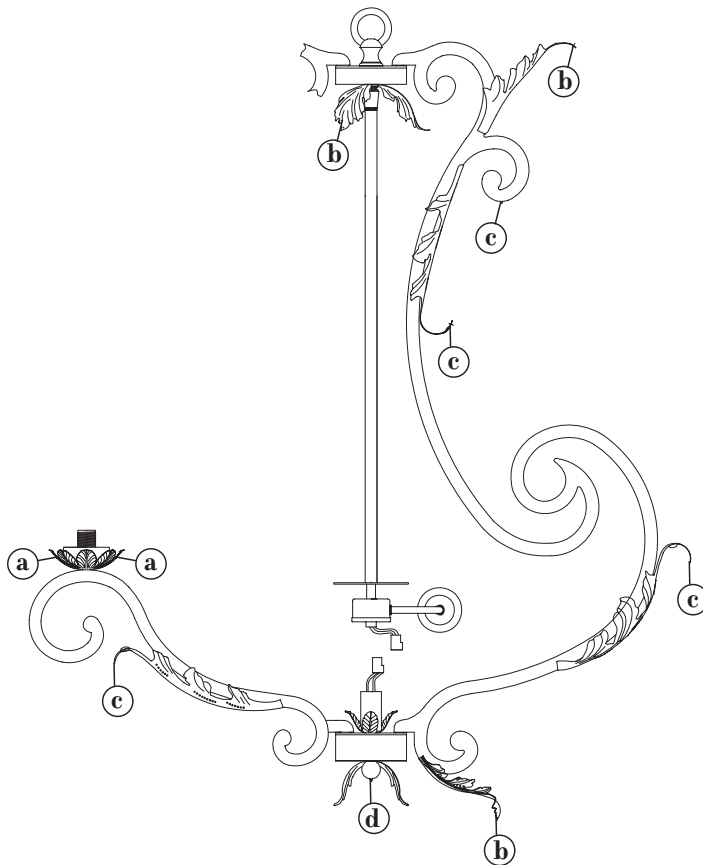

crystal 1

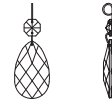

crystal 2



crystal 3

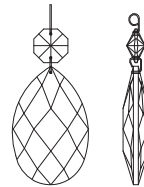

crystal 4

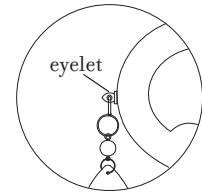

FREDRICK RAMOND
ESTABLISHED 1965

A Division of Hinkley Lighting, Inc.
33000 PIN OAK PARKWAY | AVON LAKE, OHIO 44012
toll free 800.446.5539 | phone 440.653.5500

FRIS19-50R

HANGING INSTRUCTIONS FOR FIXTURES THAT WEIGHT MORE THAN 50LBS

SAFETY WARNING: Read wiring and grounding instructions [FRIS 18] and any additional directions. Turn power supply off during installation. If new wiring is required, consult a qualified electrician or local authorities for code requirements.

STEP 1

- Shut off electrical current before starting. If the fixture you are replacing is turned on and off by a wall switch, simply turn the switch off. If not, remove the appropriate fuse (or open the circuit breakers) until the fixture is dead.
 - DO NOT restore current - either by fuse, breaker or switch - until the new fixture is completely wired and in place.
- Supply wires shall enter the outlet box (a) through any knockout EXCEPT the top center knockout - See Drawing 1.

STEP 2

- Fixture is to be mounted by a 3/8 steel pipe with 3/8 -18 NPSM thread, 3/4" threads at both ends (not supplied). Pipe should be anchored to structure or bridging member with sufficient strength to support 4 times the fixtures weight - see Drawing 2.
- Adjust pipe so 1/2" of 3/8 steel pipe extends into the junction box, at the center knockout.
- Please refer to the back of this sheet to the safety cable installation instructions and ONLY complete steps 1 and 2 at this time.

STEP 3

- Thread pipe coupler (b) onto protruding pipe inside outlet box. Secure in place by tightening allen head screw (c) see Drawing 1.
- Thread hexnut (d) onto threaded nipple (e). Thread nipple (e) into coupler (b). Secure in place by tightening hexnut (d) against coupler (b) and then tightening allen screw (f).
- thread hexnut (j) onto nipple (e). DO NOT tighten hexnut (h) at this time.
- Thread screw collar loop (k) onto end of nipple (e)
Adjust screw collar loop height so the half of the exterior thread on screw collar loop (k) is exposed when canopy (l) is held up to the ceiling.
- After screw collar loop (k) is adjusted properly, tighten hex nut (j) against screw collar loop (k) to secure loop.

STEP 4

- Determine length of chain you will require. Attach one end of length of chain to fixture.
- Slip threaded ring (m) and canopy (l) onto chain - see Drawing 1.
- Attach fixture with chain to screw collar loop (k). Please get assistance, weight and size of fixture is difficult to manage alone.
- Weave ground wire, supply wire, and safety cable through chain, up through center of screw collar loop (k), through center of nipple (e), and out the opening on the side of coupler (b).

[DRAWING 1]

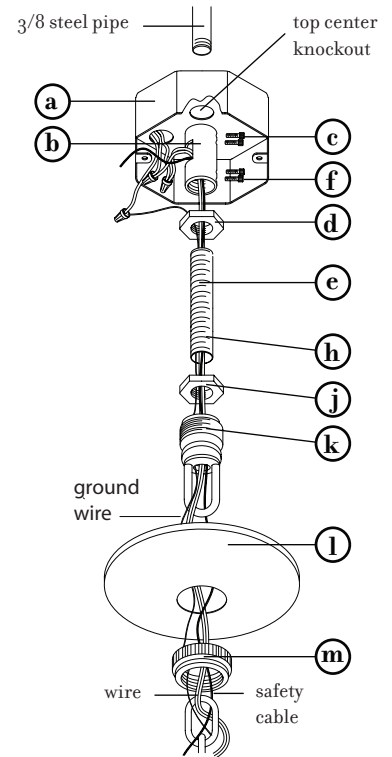

[DRAWING 2]

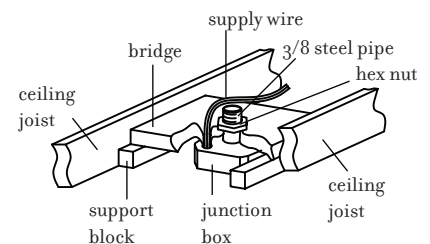

FR
FREDRICK RAMOND
 ESTABLISHED 1965

WIRING AND GROUNDING INSTRUCTIONS

SAFETY WARNING: Read wiring and grounding instructions [FRIS 18] and any additional directions. Turn power supply off during installation. If new wiring is required, consult a qualified electrician or local authorities for code requirements.

STEP 1 WIRING INSTRUCTIONS

Indoor Fixtures

- 1 Connect positive supply wire (a) (typically black or the smooth, unmarked side of the two-conductor cord) to positive fixture lead (b) with appropriately sized twist on connector - See Drawings 1 or 2.
- 2 Connect negative supply wire (c) (typically white or the ribbed, marked side of the two-conductor cord) to negative fixture lead (d).
- 3 Please refer to the grounding instructions below to complete all electrical connections.

Outdoor Fixtures

- 1 Connect positive supply wire (a) (typically black or the smooth unmarked side of the two-conductor cord) to positive fixture lead (b) with appropriately sized twist on connector - See Drawings 2 or 3.
- 2 Connect negative supply wire (c) (typically white or the ribbed, marked side of the two-conductor cord) to negative fixture lead (d).
- 3 Cover open end of connectors with silicone sealant to form a watertight seal.
 - If installing a wall mount fixture, use caulk to seal gaps between the fixture mounting plate (backplate) and the wall. This will help prevent water from entering the outlet box. If the wall surface is lap siding, use caulk and a fixture mounting platform specially.
- 4 Please refer to the grounding instructions below to complete all electrical connections.

STEP 2 GROUNDING INSTRUCTIONS

Flush Mount Fixtures

For positive grounding in a 3-wire electrical system, fasten the fixture ground wire (e) (typically copper or green plastic coated) to the fixture mounting strap (1) with the ground screw (2) - See Drawing 1.

Note: On straps for screw supported fixtures, first install the two mounting screws in strap.

Any remaining tapped hole may be used for the ground screw.

Chain Hung Fixtures

Loop fixture ground wire (e) (typically copper or green plastic coated) under the head of the ground screw (2) on fixture mounting strap (1) and connect to the loose end of the fixture ground wire directly to the ground wire of the building system with appropriately sized twist-on connectors - See Drawing 2.

Post-Mount Fixtures

Connect fixture ground wire (e) (typically copper or green plastic coated) to power supply ground with appropriately sized twist-on connector inside post. Cover open end of connector with silicone sealant to form a watertight seal - See Drawing 3.

[drawing 1]

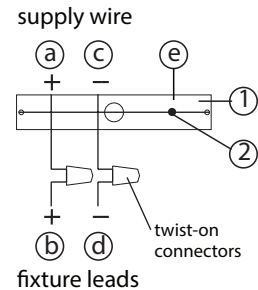

[drawing 2]

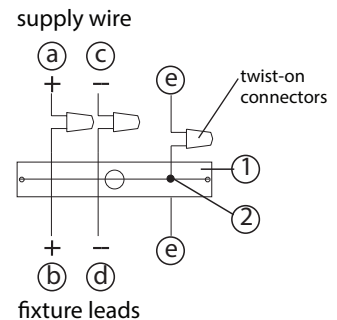

[drawing 3]

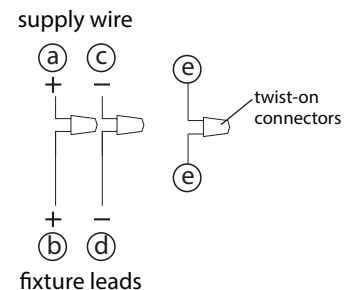

FREDRICK RAMOND
ESTABLISHED 1965

A Division of Hinkley Lighting, Inc.
33000 PIN OAK PARKWAY | AVON LAKE, OHIO 44012
toll free 800.446.5539 | phone 440.653.5500