

Manual 915 E



Contents

Monark Exercise AB	4
Product Information	5
<i>Facts</i>	<i>5</i>
<i>Serial number.....</i>	<i>5</i>
Operating Instruction.....	6
<i>Brake wheel</i>	<i>6</i>
<i>Replacement of sensor for electronic meter</i>	<i>6</i>
<i>Cycle adjustments.....</i>	<i>6</i>
<i>Workload device</i>	<i>7</i>
<i>Calibration.....</i>	<i>7</i>
<i>Computer specifications.....</i>	<i>8</i>
<i>Heart Rate</i>	<i>9</i>
Troubleshooting guide.....	9
Service.....	10
<i>Warning.....</i>	<i>10</i>
<i>Warranty</i>	<i>10</i>
<i>Service check and maintenance</i>	<i>10</i>
<i>Batteries.....</i>	<i>11</i>
<i>Crank bearing</i>	<i>11</i>
<i>Flywheel bearing.....</i>	<i>11</i>
<i>Transport.....</i>	<i>11</i>
<i>Replacement of brake belt.....</i>	<i>11</i>
<i>Brake belt contact surface</i>	<i>11</i>
<i>Chain 1/2" x 1/8"</i>	<i>12</i>
<i>Freewheel sprocket.....</i>	<i>13</i>
Spare parts.....	14

Important

Read the manual carefully before using the cycle and save it for future use.

Monark Exercise AB

Monark has 100 years' experience of bicycle production. The Monark tradition has yielded know-how, experience, and a real feel for the product and quality. Since the early 1900s, Monark's cycles have been living proof of precision, reliability, strength and service. These are the reasons why we are now the world leader in cycle ergometers and the market leader in Scandinavia in transport cycles.

We manufacture, develop and market ergometers, exercise bikes, transport bikes and specialized bicycles. Our largest customer groups are within health care, sports medicine, public authorities, industry and postal services.

For more information: www.monarkexercise.se



Product Information

Congratulations on your exercise bike!

The Monark 915 E is a small and compact exercise bike that can be calibrated. Displays watts and kcal at 60 respectively 70 rpm. This model is easy to use and extremely durable. Suitable for facilities with small areas.

The Monark 915 E is also equipped with an electronic meter that simultaneously displays the heart rate in beats per minute. (PULSE), intended cycling speed in km/h (SPEED), time (TIMER), energy in kilocalories (CALORIES) and the distance travelled in km (DISTANCE).

NOTE!

Use of the product may involve considerable physical stress. It is therefore recommended people who are not accustomed to cardio or do not feel completely healthy to first consult a physician for advice before use.

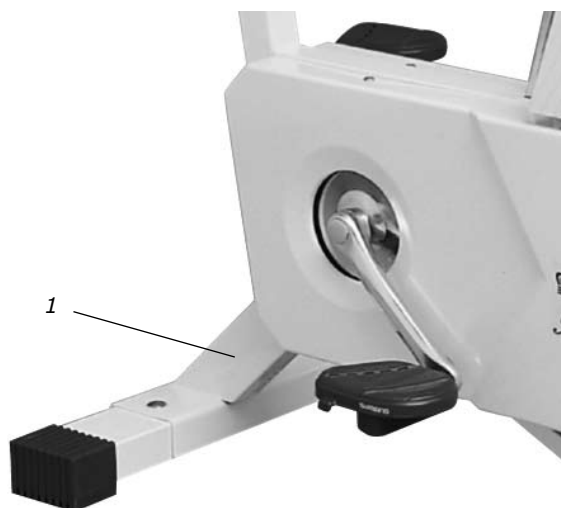

Fig: Serial number (1)

Facts

- Heavy, well-balanced flywheel, 18 kg
- Height adjustable saddle
- Adjustable handlebar
- Adjustable workload
- Stable frame, solid steel tube
- Powder painted
- Wheels for easy transport
- Electronic meter with pulse

Width

530 mm (21") at handlebar

460 mm (18") at support tube

Length

870 mm (34")

Height

75-1180 mm (29,5-4,5") at handlebar

800-1090 mm (31,5-43") at saddle

Height 650 mm (25,5") without handlebar and saddle

Weight

38 kg (83,5 lbs)

Max user weight 125 kg (276 lbs)

NOTE! Chestbelt is not included but available as an accessory.

Serial number

The serial number of your Ergometer is placed according to *fig: Serial number*.

Operating Instruction

Brake wheel

NOTE! Before you use the bike, the plastic strip must be removed from the brake flywheel. Lift the brake belt and remove the plastic strip from the brake flywheel. It is very important that all the protective tape is removed, the residue can lead to pressure in the loading device. Replace the brake belt as before. See *fig: Plastic strip*.

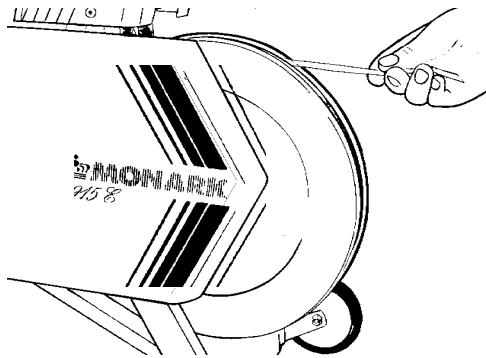

Fig: Plastic strip

Replacement of sensor for electronic meter

Remove the left chain cover. Take it apart at the cable connectors. Loosen and remove the sensor screws. Replace the sensor and assemble again according to the above in reverse order. See *fig: Sensor replacement*.

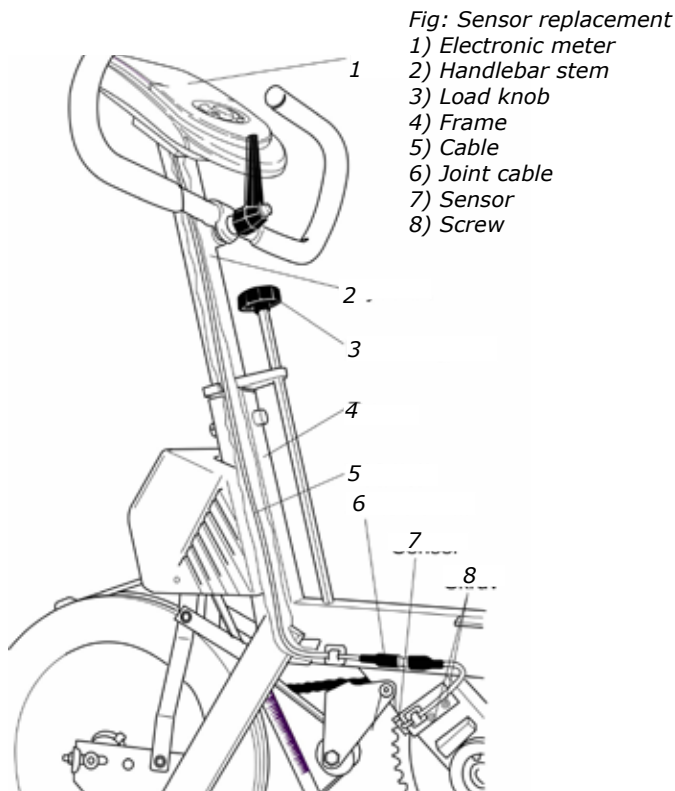

Fig: Sensor replacement

- 1) Electronic meter
- 2) Handlebar stem
- 3) Load knob
- 4) Frame
- 5) Cable
- 6) Joint cable
- 7) Sensor
- 8) Screw

Cycle adjustments

Seat height is adjusted so that it fits comfortably. The appropriate height is to have the knee slightly bent when the sole of the foot is centered over the pedal axle with the pedal to the bottom position. When adjusting the saddle height, turn the knob(1) on the seat post and pull it out. See *fig: Adjustments*.

Adjustment of the handlebar to provide a comfortable seating position. During longer period of cycling it can be appropriately to change the setting. The handlebar is adjusted by loosening the locking knob(2) on the handlebar. See *fig: Adjustments*



Fig: Adjustments
1) Knob, saddle
2) Locking knob, handlebars
3) Screw for height adjustment, handlebars, use the supplied universal tool

If the handlebar locking knob is loosened, the washer must be utilized, see *fig: Locking knob, handlebar*.

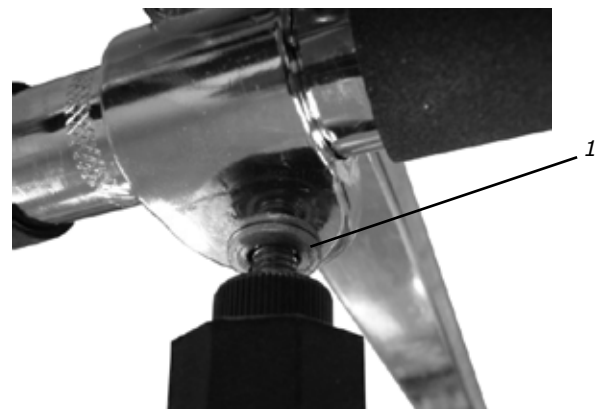

Fig: Locking knob, handlebar
1) Washer M8

Workload device

The Monark 915 E is equipped with a work load that is easily and quickly adjustable. The workload power can be read in watts at two different speeds, 60 (24 km/h) resp. 70 (28 km/h) pedal revolutions per minute. See *fig: Work load*.

By pedalling kinetic energy to the flywheel which is slowed down by a brake band which runs around the flywheel. Amendment of the workload is either another pedalling speed or using the tension knob to increase or decrease the brake band tension to the flywheel.

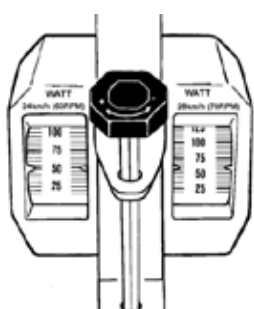

Fig: Workload

On account of the large amount of energy that builds up in the flywheel and as it has no freewheel (the pedals follow the wheel) it is most important that the user is fully aware of how the brake functions and has the shoes properly secured in the toe clip.

Adjustable brake power at speeds 60 (24 km/h) resp. 70 (28 km/h) rpm

Setting watts at speeds other than 24 and 28 km/h. For example exercise at a speed of 36 km/h and watts at 60 rpm scale read 120 watts, this is the real power is 180 watts.

Go from "60 RPM" horizontally to 120 watt and from there vertically down until you meet a horizontal line from 90 RPM. You are now exercising at 180 watt. See *fig: Conversion table*.

RPM	km/h	WATT					
40	16	20	40	60	80	100	120
50	20	25	50	75	100	125	150
60	24	30	60	90	120	150	180
70	28	35	70	105	140	175	210
80	32	40	80	120	160	200	240
90	36	45	90	135	180	225	270
100	40	50	100	150	200	250	300

Fig: Conversion table

1) Selected watt reading on the scale of 60 rpm (24 km/h)

2) Selected speed at real wattage.

Calibration

Adjust the handwheel for the tension screw so that there is no tension left in the brake belt. Fasten a 4 kg weight (Art. No: 9000-211) at the joint bracket. See *fig: Calibration*. When correct settings weight 4 kg will be read on the scale of watts 60 rpm.

If there is a deviation, dismantle the chain guard. Adjust to the correct position by means of the adjusting screw and locknut.

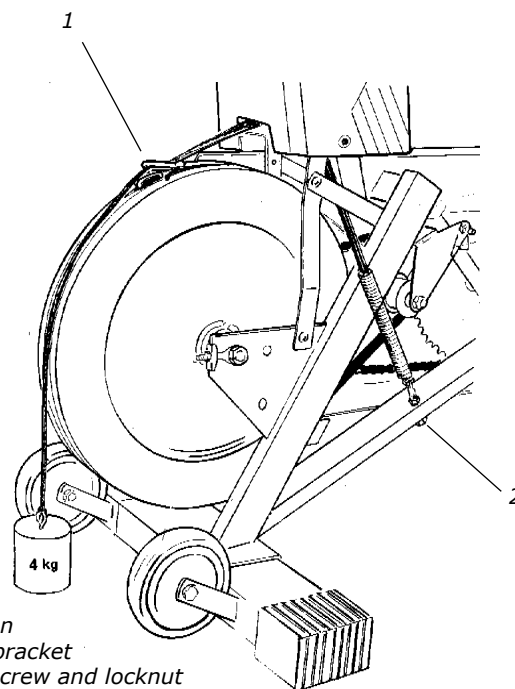

Fig: Calibration

1) Extension bracket

2) Adjusting screw and locknut

Computer specifications

Display		
SPEED	0-199	km/h
TIMER	50-99:59	min:sek
CALORIES	0-999	kcal
DISTANCE	0:00-99:99	km
PULSE	50-199	beats/min
pulse-hi	50-199	beats/min
pulse-low	30-(HI-10)	beats/min

Batteries: 1.5 Vx2, LR6, AA
 Storing temperature: -10° C - +60° C
 Operating temperature: 0° C - 50° C

MODE key

Use MODE key to set mode and cycle through the display windows as below:

PULSE HI – PULSE LOW – TIMER – CALORIES –
 – DISTANCE

SET key

Press SET key to set desired value. If you hold/press this key for two seconds or more, you can advance the function value at a faster rate.

RESET key

A press on the key will clear the values separately for TIME, DISTANCE, CALORIES (kcal) and HI/LOW pulse limit individually. If you hold down the button for more than two seconds at normal display, all values except upper and lower pulse limit will be set to zero at the same time.

PROGRAMMING

PULSE HI and PULS LOW

Press MODE key to advance to the pulse window, then use SET key to enter your desired high and low pulse rate/heart rate limit. Each press of the SET will advance five bpm. If your heart rate is above the high pulse limit you programmed, the computer will generate a beeping to warn you to stop exercise. In contrast, if your pulse rate is lower than your desired low pulse rate limit, the buzzer will also beep to remind you to continue your exercise.

EXERCISE TIME

Press MODE key to advance to the time window, then use SET key to enter your desired time. Each press of the SET key will advance time by one minute.

TARGET TRIP

Press MODE key to advance to the distance window, then use SET key to enter your desired target trip distance. Each press of the SET will advance distance by 0.5 km.

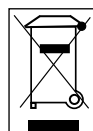

CALORIES

Press MODE key to advance to the calories window, then use SET key to enter your desired calories burned. Each press of the SET will advance calories by ten kcal. The calorie consumption is an estimated value based on the pedal rev. A better way to control exercise intensity is to use the watt scale.

TIMER

Use the MODE key to advance to the timer function. Then use the SET key to adjust to desired time. Every push on the SET key will increase the time by one minute.

CALORIES

Use the MODE key to advance to the KCAL function. Then use the SET key to adjust to desired amount. Every push on the key will increase the value by one minute.

DISTANCE

Use the MODE key to advance to the DISTANCE function. Then use the SET key to adjust to desired distance. Every push on the key will increase the distance by one km.

NOTE! If no key is pressed, or any of the pedals moved, for five seconds the display returns automatically to normal mode. The meter turns on automatically when a button is pressed or if the bike pedalling. When the bike pedalling time count starts automatically.

In normal display, please make sure the heart symbol appears on the display before measuring your pulse rate. The heart symbol will automatically disappear to save power when no key has been pressed or no signal has been received for 30 seconds or more.

By pressing SET or RESET the symbol will turn on again and the pulse function will get active.

Heart Rate

If chest belt is used (accessory).

A person's heart rate can be measured with a chest belt that senses the electronic output of the heart. The chest belt is available as an accessory.

Fuss-free HR measurement requires that the belt is correctly placed. When it is correctly fitted the logo on the belt will be central and readable, outward and upright, by another person. Before putting on the belt, clean the skin where the belt is to be placed. The chest belt should be secured at a comfortable tension around the mid section, just below the breast muscle, see *Fig: Placement of the chest belt*. Moisten the electrodes before use, see *Fig: Electrodes on the back of the chest belt*. To make contact with the HR receiver on the bike, the distance should not be more than 100 cm. It is especially important when first used to identify the chest belt with the sensor, by standing close to get the HR (maximum 60 cm).

NOTE!

Electromagnetic waves can interfere with the telemetry system. Cellular phones are not allowed to be used near the bike when using the chest belt.

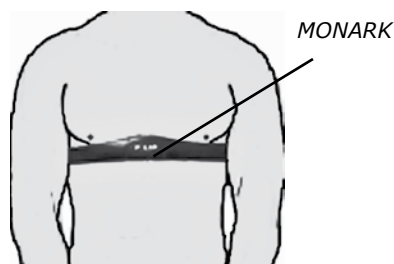

Fig: Placement of the chest belt

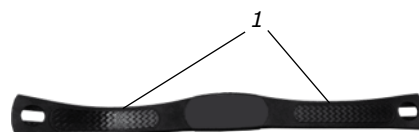

Fig: Electrodes on the back of the chest belt (1)

Troubleshooting guide

Symptoms	Probable Cause/Corrective Action
There is a click noise with every pedal revolution (increases with the weight).	The pedals are not tight. Tighten them or change pedals. The crank is loose. Check, tighten. The base bearing is loose. Contact your dealer for service.
Scratching sound is heard when pedalling.	Check that the carriage block is taken off and that none of the covers is scratching.
There is a click noise and a squeak noise when pedalling.	Loosen the chain.

Service

Note that the text about service and maintenance is universal and that all parts may not be relevant to your bike.

Warning

Make sure the voltage indicated on the appliance corresponds to the local mains voltage before making connections.

Warranty

EU countries - Private use

If you are a consumer living in the EU you will have a minimum level of protection against defects in accordance with EC Directive 1999/44/EC. In short, the directive states for that your Monark Dealer will be liable for any defects, which existed at the time of delivery. In case of defects, you will be entitled to have the defect remedied within a reasonable time, free of charge, by repair or replacement.

EU countries - Professional use

Monark Exercise products and parts are guaranteed against defects in materials and workmanship for a period of one year from the initial date of purchase of the unit. In the event of a defect in material or workmanship during that period, Monark Exercise will repair or replace the product. Monark Exercise will not, however, refund costs for labour or shipping.

Other countries

Monark Exercise products and parts are guaranteed against defects in materials and workmanship for a period of one year from the initial date of purchase of the unit. In the event of a defect in material or workmanship during that period above, Monark Exercise will repair or replace (at its option) the product. Monark Exercise will as above for labour or shipping.

Service check and maintenance

It is important to carry out a regular service on your ergometer, to ensure it is kept in good condition.

Service action:

- We recommend isopropyl alcohol to disinfect the surface of the bike. Use a damp, but not wet cloth to clean the surface you wish to disinfect.
- Clean and lubricate your Ergometer weekly.
- Periodically wipe the surface with a rust preventative, especially when it has been cleaned and the surface is dry. This is done to protect the chrome and zinc parts as well as the painted parts (4 times per year).
- Check that pedals are firmly tightened. If not, the threading in the pedal arms will be damaged. Also check that the pedal arms are firmly tightened on the crank axle, tighten if necessary. When the Ergometer is new it is important to tighten the pedals after 5 hours of pedalling (4 times per year).
- Check that the pedal crank is secure to the crank axle (4 times per year).
- Be sure that the pedals are moving smoothly, and that the pedal axle is clear of dirt and fibres (4 times per year).
- When cleaning and lubricating be sure to check that all screws and nuts are properly tightened (twice a year).
- Check that the chain is snug and there is no play in the pedal crank (twice a year).
- Check that pedals, chain and freewheel sprocket are lubricated (2 times per year).
- Be sure that the brake belt does not show significant signs of wear (twice a year).
- Check that the handlebars and seat adjustment screws are lubricated (twice a year).
- Be sure that all moving parts, crank and flywheel are working normal and that no abnormal play or sound exists. I.e. play in bearings causes fast wearing and with that follows a highly reduced lifetime.
- Check that the flywheel is placed in the center and with plane rotation.

Batteries

If the meter is battery-operated, the batteries are in a separate package at delivery. If the storing time has been long the battery power can be too low to make the computer act correctly. Batteries must be changed.

Crank bearing

The crank bearing is greased and normally requires no supplementary lubrication. If a problem arises, please contact your Monark dealer.

Flywheel bearing

The bearings in the flywheel are greased and do not normally require maintenance. If a problem arises, please contact your Monark dealer.

Transport

At transport the brake belt should be tightened to prevent it from falling off the flywheel.

Replacement of brake belt

To replace the brake belt remove covers if necessary. Make sure that the belt is loose.

Alt. 1: To loosen the belt on pendulum bikes with a motor, turn the power on and move the pendulum to 4 kp. Hold it there until the brake belt is loose. Observe how the belt is connected. Take it apart and remove it from the bike. Attach the new brake belt and assemble the bike in reverse order.

Alt. 2: To loosen the brake cord on cycles with a weight basket set the basket to its upper position. Loosen the lock washer that is holding the cord and remove it from the tension center. Loosen or cut off the knot on the other end of the cord and then remove the whole cord from the bike. When assembling a new brake cord, first enter one end into the hole in the tension center, tie a knot and let the knot fall into the bigger part of the hole. Lock the end of the cord with the lock washer.

Alt. 3: To loosen the belt on other bikes remove all possible tension. Observe how the belt is connected. Take it apart and remove it from the bike. Attach the new brake belt and assemble the bike in reverse order.

NOTE: When replacing the brake belt it is recommended to clean the brake surface. See "Brake belt contact surface".

Brake belt contact surface

Deposits of dirt on the brake belt and on the contact surface may cause the unit to operate unevenly and will also wear down the brake belt. The contact surface of the flywheel should be smoothed with fine sandpaper and any dust removed with a clean dry cloth.

Remove any covers and loosen the tension on the brake belt. Smooth with fine sandpaper. This is easier to perform if a second individual cautiously and carefully pedals the cycle.

Irregularities on the brake belt contact surface are removed by means of a fine sandpaper or an abrasive cloth. Otherwise unnecessary wear on the brake belt may occur and the unit can become noisy.

Always keep the brake belt contact surface clean and dry. No lubricant should be used. We recommend replacing the brake belt when cleaning the contact surface. In regard to assembly and adjustment of the brake belt, see "Replacement of brake belt".

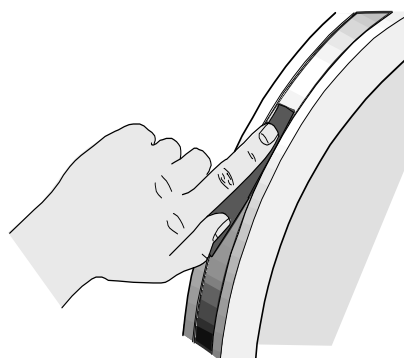

Fig: Brake belt contact surface

Chain 1/2" x 1/8"

It is strongly recommended to keep the chain clean. Dirt build-up on the chain will cause excess wear. A chain lubricant and solvent for normal road bikes may be used.

Check the lubrication and tension of the chain at regular intervals. In the middle of its free length the chain should have a minimum play(3) of 10 mm (1/4 inch). See *fig: Chain adjustments*. When the play in the chain is about 20 mm (3/4 inch) it must be tightened otherwise it will cause abnormal wear of the chain and chainwheels. Because of this it is always recommended to keep the chain play as little as possible. Loosen the hub nut(2) on both sides and tense the chain with the chain adjuster(1) when needed.

When the chain has become so long that it can no longer be tightened with the chain adjusters it is worn out and should be replaced with a new one.

To adjust or replace the chain remove frame covers if necessary.

To adjust the chain the hub nuts(2) should be loosened. Loosening or tightening the nuts on the chain adjusters(1) will then move the hub and axle forward or backward. Adjust according to above recommendation. Then tighten the nuts on the hub axle again. See *fig: Chain adjustments*.

To replace the chain, loosen the chain adjuster as much as possible. Dismantle the chain lock(6) and remove the chain. Put on a new chain and assemble the chain lock. The spring of the chain lock should be assembled with the closed end in the movement direction(5) of the chain. Use a pair of tongs for dismantling and assembling the spring(4). See *fig: Chain replacement*.

NOTE: At assembly, the flywheel has to be parallel with the centerline of the frame otherwise the chain and chain wheels make a lot of noise and wear out rapidly.

Adjust chain adjusters to allow chain play according to above. Tighten hub nuts firmly. Replace frame covers.

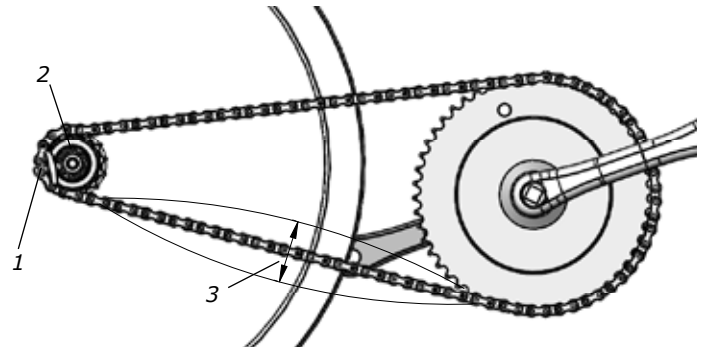

Fig: Chain adjustments
1) Chain adjuster
2) Hub nut
3) Chain play

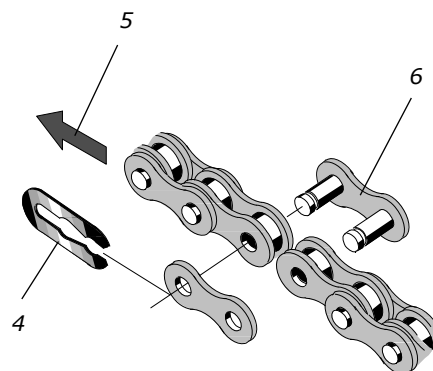

Fig: Chain replacement
4) Lock spring
5) Movement direction
6) Chain lock

Freewheel sprocket

When replacing the freewheel sprocket remove frame covers if necessary. Dismantle the chain as described in part "Chain 1/2" x 1/8" ".

Loosen the axle nuts and lift off the flywheel. Remove the axle nut, washer, chain adjuster and spacer on the freewheel side. Place the special remover (Art. No: 9100-14) in the adaptor and place the spacer and axle nut outside. See *fig: Special remover*. Replace sprocket-adaptor and assemble the new parts in reverse order according to the above.

NOTE: Do not tighten the axle nut completely. It must be possible to loosen the adaptor-sprocket half a turn.

The sprocket should be lubricated with a few drops of oil once a year. Tilt the cycle to make it easier for the oil to reach the bearing. See *fig: Lubrication*.



Fig: Lubrication



Fig: Special remover
(Art. No: 9100-14)

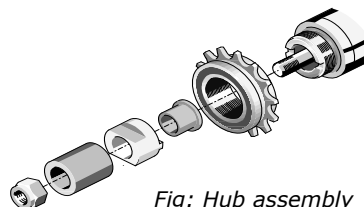
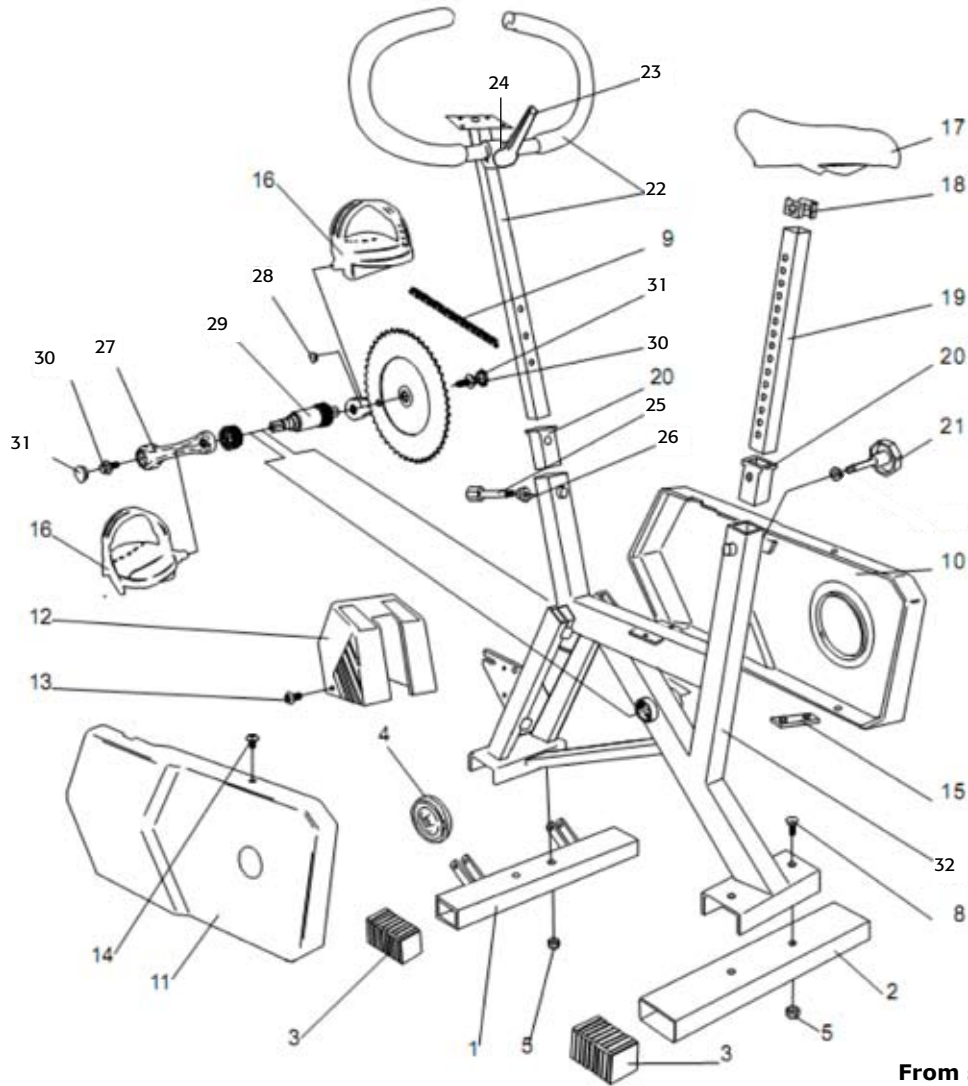

Fig: Hub assembly

Spare parts



From serial number: WBK 278240

Pos.	Qty.	Art. No.	Description	Pos.	Qty.	Art. No.	Description
1	1	9300-5	Support tube, front	19	1	9300-113	Saddle post
2	1	9300-6	Support tube, rear	20	2	9300-115	Bushing for saddle post (on 915 also for handlebar stem)
3	4	9300-7	Plastic cap, blue	21	1	9300-133	Locking screw, complete
4	2	9000-29	Transport wheel, complete		1	9300-122	-Locking knob
5	6	5844	Lock nut M8		1	9300-134	-Pressure washer, complete
8	2	9300-12	Screw MVBF, M8 x 16 mm	22	1	9326-565	Handlebar, complete
9	1	9326-55	Chain 1/2" x 1/8", 98 links	23	1	9326-107	-Lever, complete
	1	1109	-Chain lock	24	1	5864	-Washer M8
10	1	9326-250	Chain Guard	25	1	9326-67	Locking screw
11	1	9326-251	Side guard	26	1	9300-134	Pressure washer, complete
12	1	9326-52	Cover for watt meter	27	1	9300-401	Crank, complete
13	4	5673-9	Mounting screw LKT-TT, 5x12 mm, stainless	28	1	9326-164	Magnet
14	3	5675-9	Mounting screw LKT-TT, 5x6.5 mm, stainless	29	1	8966-175	BB cartridge bearing, complete
15	1	9300-53	Holder for guard	30	2	8523-115	Screw M6S 8.8 M8 x 1 x 20 fzb
16	1	9300-215	Pedal 9/16", pair		2	8523-2	Dust cover
16	1	9300-207	Pedal strap, pair		1	9326-1	Frame
17	1	4992-5	Saddle				
18	1	9300-114	-Saddle bracket				

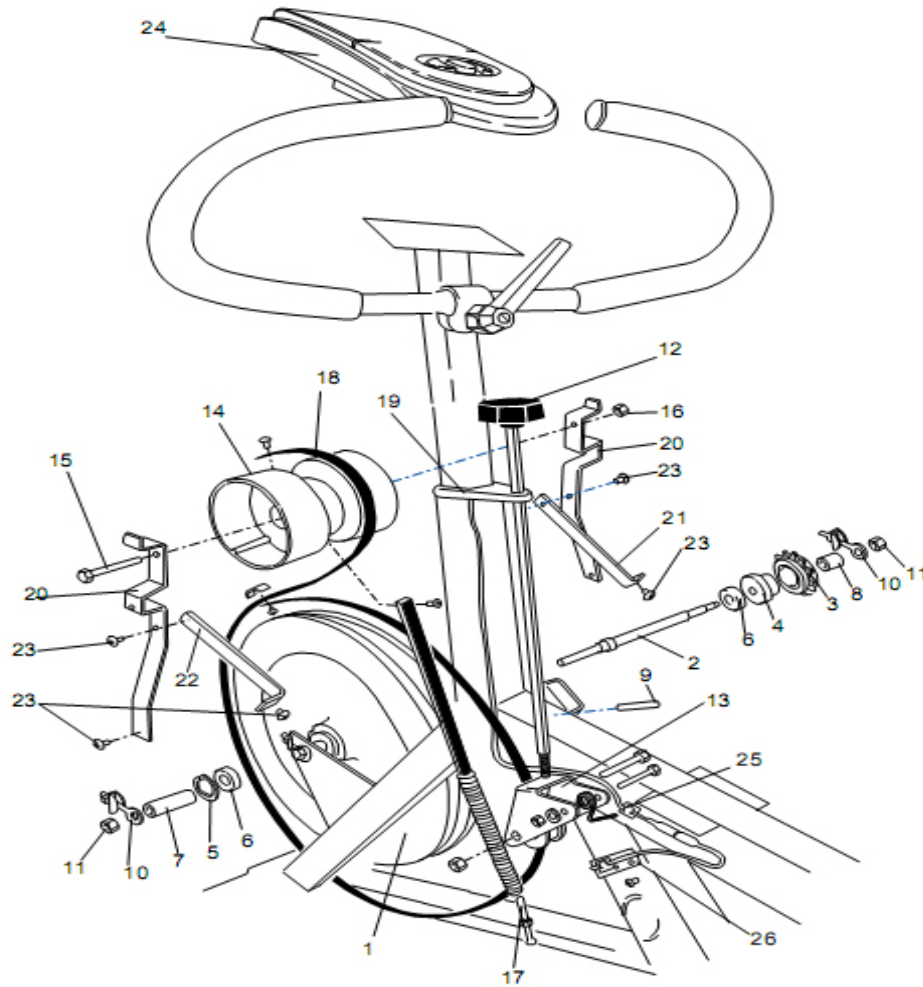

From serial number: WBK 278240

Pos.	Qty.	Art. No.	Description	Pos.	Qty.	Art. No.	Description
1	1	9326-30	Flywheel, complete	17	1	9326-58	Calibration screw, complete
2	1	9300-18	-Axle	18	1	9326-56	Brake belt, complete
3	1	9106-13	-Sprocket 14 t, M30 x 1 g	19	1	9326-85	Support for tension screw
4	1	9106-14	-Connection for same	20	2	9326-81	Holder
5	1	9000-15	-Locking ring SgH 028	21	1	9329-82	Stay, right
6	2	19001-6	-Bearing 6001-2z	22	1	9326-83	Stay, left
7	1	9300-17	-Spacer 23 mm	23	10	5675-9	Mounting screw M5x6.5 mm
8	1	9000-17	-Spacer 5 mm	24	1	9327-264	Electronic meter
9	1	9010-38	-Tension pin 5 x 18 mm		1	9326-262	-Cable
10	1	9000-12	-Chain adjuster		1	2151	-Battery 1,5 V, LR6, AA
11	2	5799	-Axle nut	2	2	9326-59	Screw RXS B8 x 9.5 mm
12	1	9326-86	Tension screw, complete		1	9326-166	Holder for sensor
13	1	9326-57	Tension lever, complete	25	2	9300-66	Bracket for cable
14	1	9326-84	Watt scale, complete	26	2	9326-162	Crank sensor with cable
15	1	14367	Screw M8 x 90 mm		1	9339-98	Chestbelt with pulse transmitter (accessory)
16	1	5844	Nut M8				



Version 1207
Art. No: 7950-314

