

Included:

Position	Description	Numbers
1	Magnet with adhesive pad	6
2	Assembly sticker	1

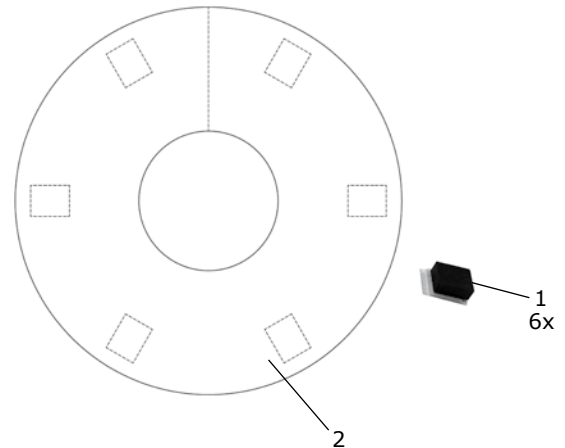

1. Remove the belt control in the front of the bike, see *Fig: 1* and *Fig: Full view*.
2. Loosen the instrument cover and disconnect the cable from the meter. Remove the instrument cover. See *Fig. Full view*. Loosen the front part of the left frame cover. See *Fig: 2*. The frame cover do not need to be removed completely, just loosen it so it is possible to reach the hub on the flywheel.
3. Remove the existing magnet from the flywheel by knocking it carefully with e.g. a small hammer.

Fig: 1



Fig: 2



Fig: Full view



Fig: Full view

- 1) Instrument cover
- 2) Belt control
- 3) Left frame cover

4. Cut at the mark on the assembly sticker, see *Fig: 3*.
5. Hold the assembly sticker in place around the hub on the left side of the flywheel. Remove the protective paper step by step while you fasten the assembly sticker. See *Fig: 4*.
6. Remove the protective tab from the magnets and fasten them in the marked fields on the assembly sticker, see *Fig: 5*.
7. Reattach the frame cover. Connect the cable to the meter and reattach the instrument cover. Reattach the belt control.

Computer software

Update the computer software using the supplied CD-ROM by following the instructions displayed on the computer screen. If problems occur, see the software's help file.

Before use

Check that the RPM display in the computer program is consistent with that shown in the cycle meter. If not, contact the service department at Monark Exercise AB.

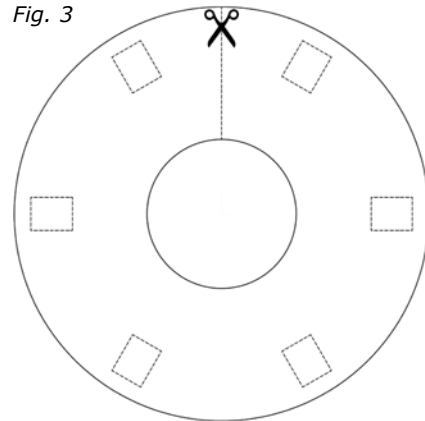
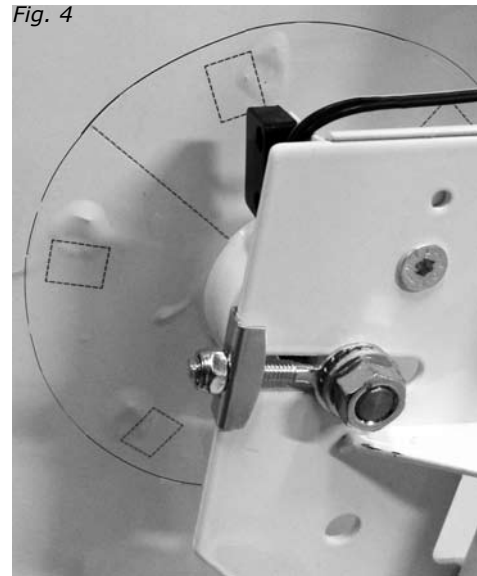
Fig. 3*Fig. 4**Fig. 5*