

Manual 894 E



Contents

Monark Exercise AB	4
Product Information	5
<i>Facts</i>	5
<i>Serial number.....</i>	5
Operating Instruction.....	6
<i>Workload adjustment</i>	6
<i>Power measurement.....</i>	6
<i>Cycle adjustments.....</i>	6
<i>Connection to PC.....</i>	7
<i>Anaerobic testing</i>	7
<i>Meter instructions.....</i>	8
<i>Heart Rate</i>	9
<i>Adjusting the brake cord/belt tension.....</i>	10
Trouble shooting guide.....	11
Service.....	14
<i>Varning.....</i>	14
<i>Warranty</i>	14
<i>Service check and maintenance</i>	14
<i>Batteries.....</i>	15
<i>Crank bearing</i>	15
<i>Flywheel bearing.....</i>	15
<i>Transport.....</i>	15
<i>Replacement of brake belt.....</i>	15
<i>Brake belt contact surface</i>	15
<i>Chain 1/2" x 1/8"</i>	16
<i>Freewheel sprocket.....</i>	17
Spare parts.....	18

Important

Read the manual carefully before using the cycle and save it for future use.

Monark Exercise AB

Monark has 100 years' experience of bicycle production. The Monark tradition has yielded know-how, experience, and a real feel for the product and quality. Since the early 1900s, Monark's cycles have been living proof of precision, reliability, strength and service. That are the reasons why we are now the world leader in cycle ergometers and the market leader in Scandinavia in transport cycles.

We manufacture, develop and market ergometers and exercise bikes, transport bikes and specialized bicycles. Our largest customer groups are within health care, sports medicine, public authorities, industry and postal services.

For more information: <http://www.monarkexercise.se>



Product Information

Congratulations on your new Ergometer!

The Monark 894 E is an ergometer for anaerobic tests that also works as a normal traditional weight ergometer. It is provide with a break, which controls by putting weights in a weight basket. RPM-controlled release of weight basket and test duration up to 99 minutes increase safety and the potential for optimal tests.

The easy-to-use Windows-based software has more setting possibilities with clear presentation graphics. Thanks to double sensors, faster electronics and improved mechanics, performing anaerobic tests is now more efficient and less complicated.

NOTE!

Use of the product may involve considerable physical stress. It is therefore recommended people who are not accustomed to cardio or not feel completely healthy to first consult a physician for advice.

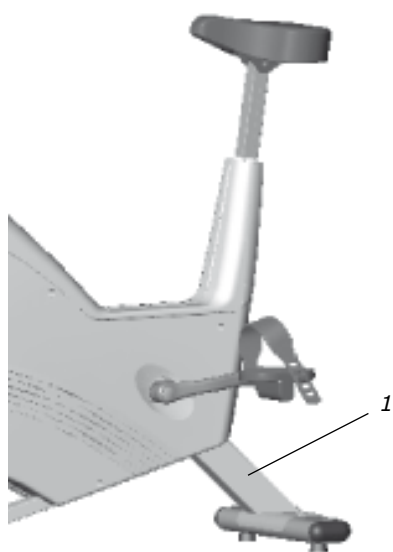

Fig: Serial number (1)

Facts

- Large, well-balanced flywheel 20 kg (48 lbs)
- Adjustable saddle and handlebar
- Stable frame, solid steel tube
- Powder painted
- Wheels for easy transport
- Electronic meter with heart rate

Width

517 mm (20") at handlebar

640 mm (25") at support tubes

Length

1120 mm (45")

Height

945-1295 mm (37-51") at handlebar

780-1105 mm (31-44") at seat

Weight

65 kg / 144 lbs (without weights)

Max user weight 125 kg (550 lbs)

Included

- Chestbelt
- PC-program
- Power adaptor/switching adaptor
- Weight kit consisting of:
 - 4 pcs. 0.1 kg (0.2 lbs)
 - 1 pcs. 0.5 kg (1.1 lbs)
 - 8 pcs. 1.0 kg (2.2 lbs)

Technical data power adaptor

Output voltage: +9 V DC

Current: 500 mA

Polarity: Minus (-) in the middle of connector. See Fig: Polarity.

(Art. No. 9384-650, USA Art. No: 9384-62)

Serial number

The serial number is placed according to fig: Serial number.



Fig: Polarity

Operating Instruction

Workload adjustment

Through pedalling the test person supplies kinetic energy to the flywheel. The flywheel is then braked by means of a brake belt/cord which runs around the flywheel. The workload is changed either by using other pedalling speed or by increasing or decreasing the tension of the brake belt/cord against the flywheel by place weights in the weight basket. Weights are available in 1 kg / 2.2 lb, 0.5 kg / 1.1 lb and 0.1 kg / 0.2 lb. This makes it possible to vary the workload from 1 kp up to maximum 11 kp in steps of 0.1 kp. Braking power is expressed in kp where mass 1 kg / 2.2 lb gives the braking force 1 kp.

NOTE! 1 kg / 2.2 lbs is the lowest work load that can be set as this is the weight of the basket itself. A weight basket that only weighs 0.5 kg / 1.1 lb is available as an option. The weight basket can also be set in its upper free/resting position and does then not give any work load at all. The weight basket is released by pushing the release button (1), on the handlebar. See *Fig: Workload adjustment*.

Power measurement

The cycle is designed to measure the power on the flywheel, because tests/protocols are made for it (for example Åstrand's and YMCA).

Cycle adjustments

Seat height should be adjusted to a comfortable position. The appropriate height is to have the knee slightly bent when the sole of the foot is centred over the pedal axle with the pedal to the bottom position. To adjust the seat height loosen the lever(1) on the seat tube. See *Fig: Adjustments*.

The handlebar setting should be in a comfortable position when cycling. During longer exercise sessions it is recommended to occasionally change handlebar position. To adjust the handlebar, loosen the quick release lever(2). See *Fig: Adjustments*.

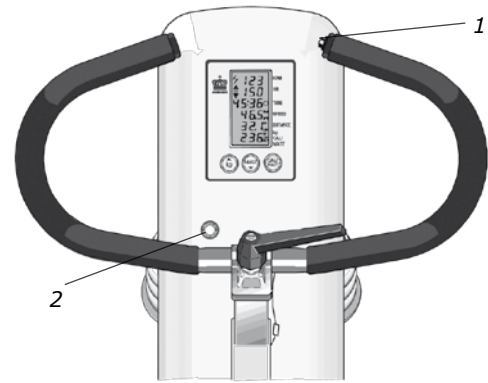

Fig: Workload adjustment
1) Release button, release basket
2) LED

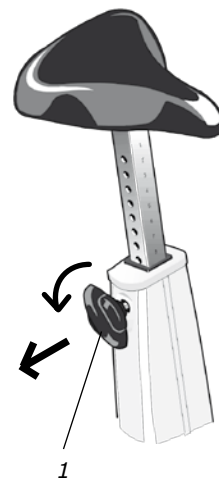
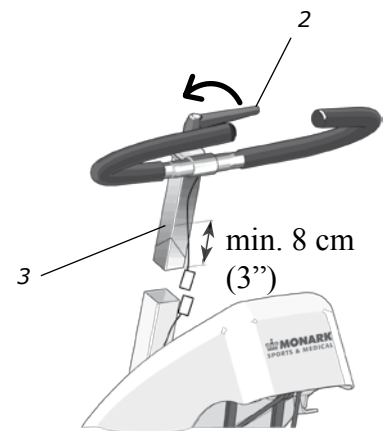

Fig: Adjustments
1) Quick release bolt
2) Quick release lever
3) Inserted min. 3"



NOTE! The handlebar stem should be inserted into the frame tube at least 3 inches (about 8 cm). This measure is marked with "MAX" on the stem(3).

Connection to PC

To connect a PC to the ergometer, use a 0-modem cable (RS232) with a 9-pin D-sub female at each end. If no RS232 serial port is available on the PC use a USB serial adaptor to connect to an USB port.

Follow these steps to install the USB adaptor drivers:

1. Locate the USB adaptor.
2. Inside the USB adaptor packaging, there is a mini-CD.
3. Insert the mini-CD into the CD-ROM drive and install the driver software. If there is no CD drive on your computer, driver software is available for down from the website (<http://www.vscom.de/USB-CD>).
4. Finalize the driver software installation by inserting the USB adaptor.
5. Install the Monark Software disk.
6. Connect the USB Adapter to the Serial Cable and proceed with testing.

Anaerobic testing

Model 894 E has a computer for anaerobic testing and makes the bike possible to connect to an external PC, PC-cable is included. A Windows application, included in the bike, makes it possible to make a lot of different type of anaerobic tests for ex. Wingate tests and so forth. The anaerobic tests can easily be set from 5 up to 300 seconds duration. For a closer explanation of the application look in the program manual, "Monark Anaerobic Test Software User Manual".

NOTE! To carry out anaerobic tests must cycle computer equipped with power from a wall outlet. Connect the supplied power adaptor into an appropriate wall outlet (230 V). The circular connector on the secondary cable from the power adaptor is connected to the corresponding socket on the cycle under the instrument cover on the right side. PC cable is connected into the serial port underneath and to a serial port on an external PC. See *Fig: Brake device* in section "Adjusting the break cord/belt tension". The LED (2) on the front of the instrument panel, see *Fig: Workload adjustments* in section "Workload device", indicates both that there is power to the unit and that the weight basket is in its upper locked position. If the weight basket produces resistance it must be moved up in its upper locked position where it does not give any workload. Then the LED is lit - with a delay of about five seconds - indicating that the computer and cycle is in a ready position for a test.

Meter instructions

Display		
RPM	0 - 250	rev./min.
HR	50 - 240	bpm
TIME	0:00-99:59	min:sec
SPEED	0 - 99	km/h
DISTANCE	0.0 - 99.9	km
FORCE	0.0 - 7.0	kp
Calories (CAL)	0 - 999	kcal
WATT	0 - 7 x rpm	watt

Batteries: 1.5 V x 2, R6 (AA)
 Storing temperature: -10° C - +60° C / 14-140 F
 Operating temperature: 0° C - 50° C / 32-122 F

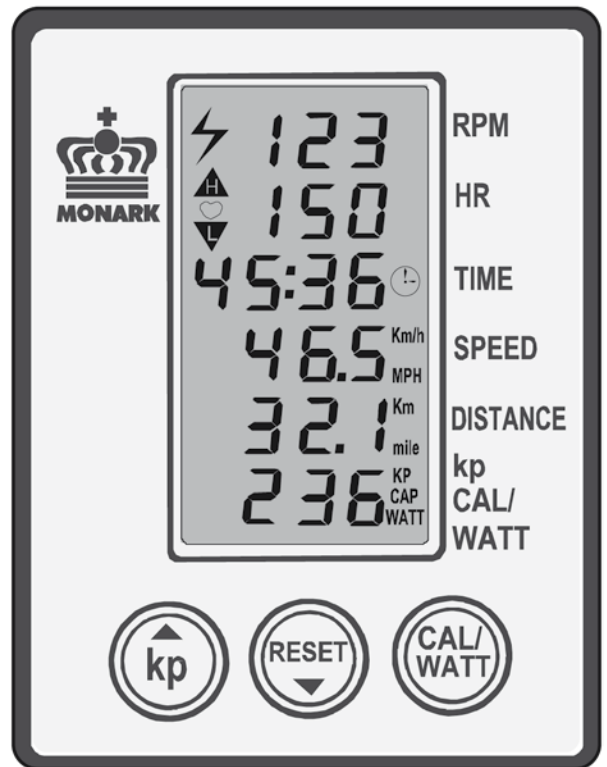
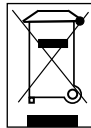

The ergometer is equipped with a Fitness computer showing pedal revolutions per minute (RPM), heart rate in bpm (HR), exercise time in minutes and seconds (TIME), cycling speed in km per hour or miles per hour (SPEED), covered distance in km or mile (DISTANCE). Furthermore the workload (kp = weight basket + weights in kg) can be set which gives a reading of burned calories (CAL) as well as power (WATT) on the computer display. The energy is usually expressed in kJ (kilojoule) or cal (kilocalories, kcal). One kcal is approx. 4,2 kJ. The power is depending on the pedalling speed which makes it possible to adjust the workload/power by increasing or decreasing the pedalling speed.

Press any button or move the pedal to turn on the meter.

At the display for heart rate (HR) a heart symbol is lit which means that the meter is trying to find a pulse signal from an external source (chestbelt with electrodes, Art. No: If the meter cannot find such a signal this HR function is automatically turned off after 30 seconds. When the function is turned off the heart symbol is not lit any more. The heart rate function can be turned on again by pressing a key.

The timer starts automatically when pedals are moved. Meter values for Time, Distance and Calories can be set to zero by pressing the RESET button for more than two seconds.

To get correct readings for calories and watts the kp value on the electronic meter has to be set to the same value as the workload that is the weight of the basket including the weights in it. The rubber plates are included in the calibrated weight of the 1 kg weight basket.

Example: The workload is 3 kg / 6.6 lbs (weight basket 1 kg / 2.2 lbs + 2 x 1 kg / 1.1 lbs weight). Press the kp key to the left on the meter. The lower display window is now flashing and showing figures in kp. Increase or decrease in steps of 0.1 kp by pressing the kp button (arrow up) or the RESET button (arrow down) until the reading is corresponding with the actual or desired kp values (workload) from the weight basket. After that press the CAL/WATT button to either show the CAL or WATT figures. After that press the CAL/WATT button to either show the CAL or WATT figures. The watt reading in the display is depending on the pedalling speed. The watts can accordingly be adjusted by increasing or decreasing the pedalling speed. Calories are calculated all the time.

Km/Miles

Km and km/h is the default setting from the factory. If you want to make a setting in miles take the meter out of the panel. Turn off the meter by taking out one battery. On the back side is a switch (1) with two settings – 1 and ON. See Fig: Switch km/miles. 1 is equal to km and km/h and is the default setting. ON is equal to mile and mph. Choose position and install the battery again. Put the meter back again into the panel.

Do not expose the electronic meter to direct sunlight or extremely high temperature. Do not use any dissolvents when cleaning. Use only dry cloth.

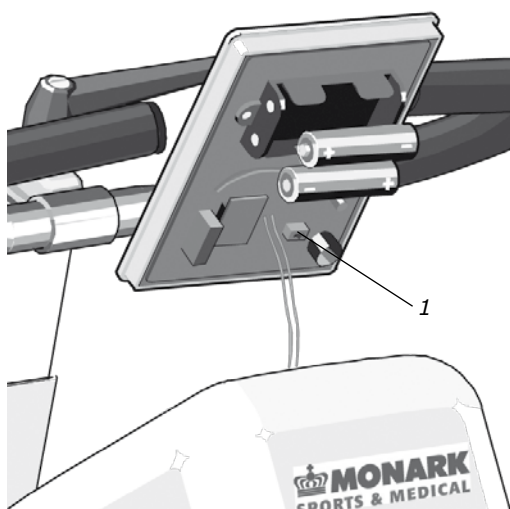

Fig: Switch km/miles (1)

Heart Rate

A person's heart rate can be measured with a chest belt that senses the electronic output of the heart. The chest belt is standard equipment.

Fuss-free HR measurement requires that the belt is correctly placed. When it is correctly fitted the logo on the belt will be central and readable, outward and upright, by another person. Before putting on the belt, clean the skin where the belt is to be placed. The chest belt should be secured at a comfortable tension around the mid section, just below the breast muscle, see Fig: Placement of the chest belt. Moisten the electrodes before use, see Fig: Electrodes on the back of the chest belt. To make contact with the HR receiver on the bike, the distance should not be more than 100 cm. It is especially important when first used to identify the chest belt with the sensor, by standing close to get the HR (maximum 60 cm).

NOTE!

Electromagnetic waves can interfere with the telemetry system. Cellular phones are not allowed to be used near the bike during test.

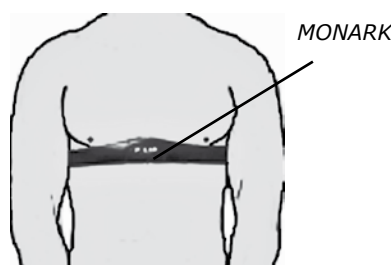

Fig: Placement of the chest belt

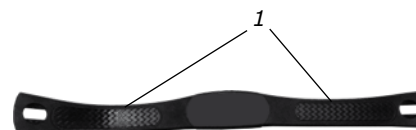

Fig: Electrodes on the back of the chest belt (1)

Adjusting the brake cord/belt tension

1. Check at first that the brake belt is lying correct on the flywheel brake surface. See *Fig: Brake cord* and *Brake device*. If the weight basket is in its upper position, press the release button(1). The basket will fall down and increase the tension of the brake belt/ cord against the flywheel. Put 9 kg /10 lbs in the weight basket(6). See *Fig: Brake device*. Rotate the flywheel by hand. The basket shall now lift up so the distance to the flywheel is at least 40 mm /1.5" and maximum 60 mm / 2.4". If this is not the case the brake belt has to be loosened or tightened a little at the tension center. If the basket is too low, shorten the belt somewhat. If the basket is too high, lengthen the cord somewhat. Tighten the bracket again and release and check if the measurements above are OK when the flywheel is rotated by hand.

2. Also check the brake cord tension with no load weight basket. Then check the distance between the pin on the tension center and the tip of the magnet arm, as shown in *Fig: Brake device*. This distance should be between 5 and 10 mm (1/4" and 1/2").

NOTE!

To receive correct workload it is important to place the weight basket according to the description above.

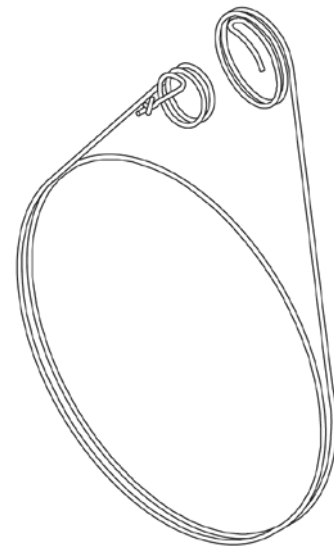
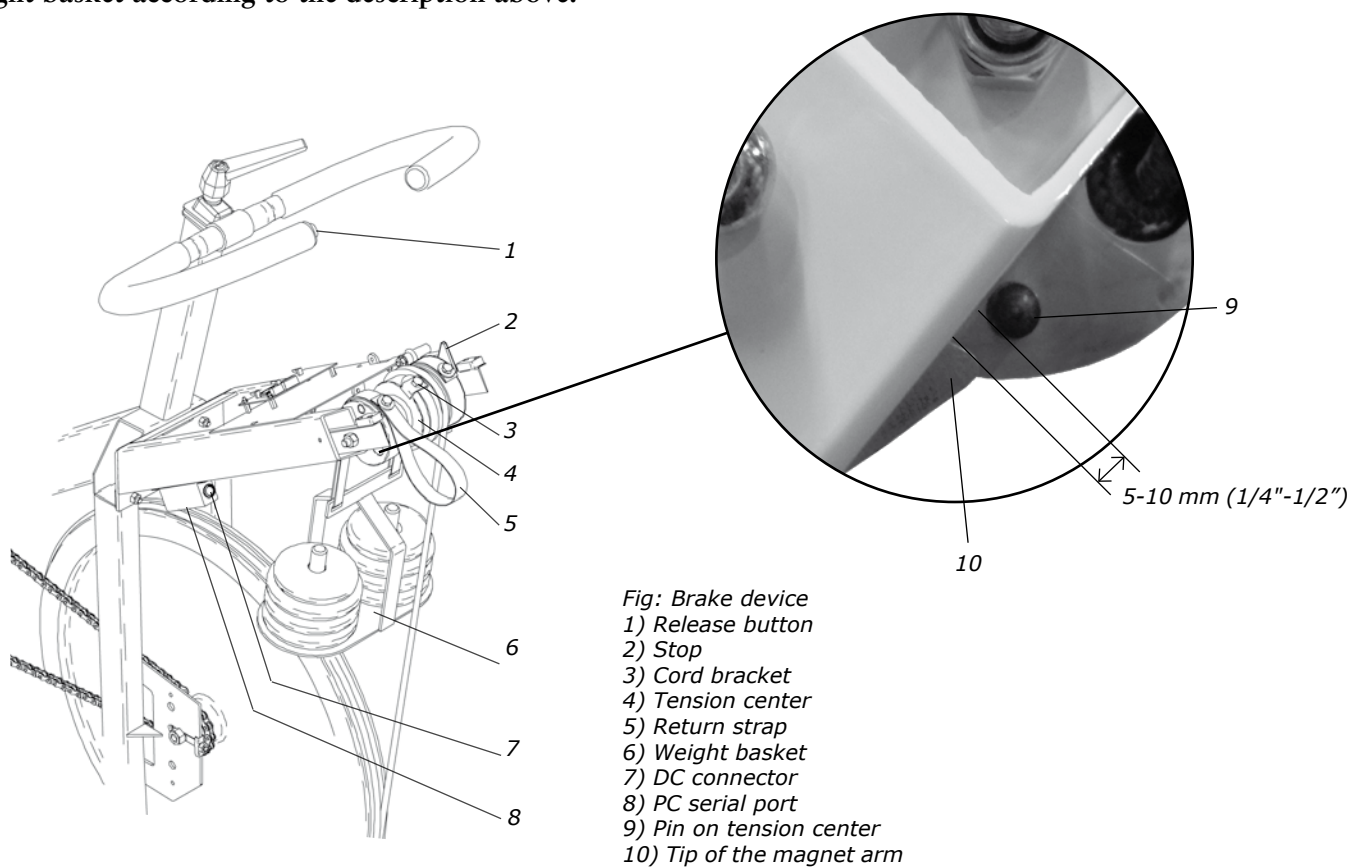
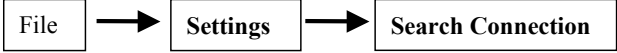

Fig: Brake cord



Trouble shooting guide

Symptoms	Probable Cause/Corrective Action
There is a click noise with every pedal revolution (increases with the weight).	The pedals are not tight. Tighten them or change pedals. The crank arms are loose. Check, tighten. The base bearing is loose. Contact your dealer for service.
Scratching sound is heard when pedalling.	Check that the carriage block is taken off and that none of the covers is scratching.
There is a click noise and a squeak noise when pedalling..	Loosen the chain.
The display is not working.	Check that the batteries are OK.
Timekeeping does not start.	Check if the brake belt is too tight so the magnet will not pass the sensor. This will result in no signal from sensor. There is a video available of website www.monark.net which describe adjustment.
Bike would not start. Weight basket does not lock in upper position.	<ol style="list-style-type: none"> 1. Power adaptor is not connected. 2. Main switch is not in ON position. Located on bikes right side underneath tension device. 3. The power jack is not functioning, the fuse is blown. 4. Incorrect type of power adaptor is used. A marking label should be found with the text "Peak bike 894 E". 5. Power adaptor is broken and needs to be replaced.
The yellow LED lamp will not light up when the weight basket is hoisted up (should light within 2-3 seconds after the basket been hoisted up).	<ol style="list-style-type: none"> 1. Check that magnets on both side of tension device has not fallen off and without damages. 2. Check so basket lock sensor and basket drop sensor is working properly and also connected to correct ports on bikes circuit board. See <i>Fig: Connections on Circuit board</i>.
Problems with the sensors.	<p>Technical advice how to check sensors of magnetic type:</p> <ol style="list-style-type: none"> 1. Unplug the sensor on bikes circuit board. 2. In the jack in the end of sensor cable measure with a summer or an ohmmeter then angle the magnet in near of the sensor. A signal should be heard or value approx. 0 ohm displayed on ohm meter.
No heart rate.	<p>Check the chestbelt (battery). Wet the thumbs and place them on the electrodes. A low clicking sound will appear near battery lid while you click on the electrodes with one thumb.</p> <p>Check that the chest belt is positioned correct on test person and tight enough. Check that the electrodes are wet. In hard cases it is necessary to use a contact gel or a mixture of water with a few drops of washing-up liquid. The level for HR signal can vary from person to person. Put chestbelt on another known person who has a good pulse rendering.</p>
Uneven heart rate.	<p>Use an external unit, for example a pulse watch, to check if it also indicates irregular pulse. If this is the case, there is probably disturbance in the room. Magnetic fields from high voltage cables, elevators, fluorescent tube etc. can cause the disturbance. Other electronic equipment could be placed too close. Move the bike to a different location in the room or change rooms. If irregular pulse remains we recommend measuring HR manually. If HR still remains irregular at workload test person's health need to be examined.</p>

Symptoms	Probable Cause/Corrective Action
<p>Communication could not be established between the bike and the computer. No RPM visible in Monark software.</p>	<ol style="list-style-type: none"> 1. Data cable between the bike and the computer is not connected or it is damaged. 2. Incorrect type of data cable is used. Correct type 0-modem cable. 3. Start button in Monark software has not been activated. 4. Communication settings within the Monark software is not correct. Try to change COM-port. In the software's menu click on – <div style="text-align: center; margin: 10px 0;">  <pre> graph LR A[File] --> B[Settings] B --> C[Search Connection] </pre> </div> <p>Choose the suggested COM-port in the box to the right and confirm by click OK.</p> <ol style="list-style-type: none"> 5. The computer's serial port is broken or its settings are incorrect. Contact your network administrator to check the computer and software installation. Alternative you could try to install Monark software on a different computer. <p>Technical accessory, COM-port tester (Art. No: 9394-525) can be used if you have problems with the communications between bike and PC. Procedure:</p> <ol style="list-style-type: none"> 1. Connect the data cable between the COM-port tester and the bike. 2. Connect power adaptor and turn the main switch to ON. 3. The green LED on the COM-port tester should light up. This will indicate that the bike's circuit board is powered on. 4. When the weight basket is hoisted up, the red LED on the tester flash briefly. The same thing will happen when the weight basket is dropped again. 5. When a person starts to pedal the bike the red LED on COM-port tester will flash in the same tact as the RPM. <p>If all expected flashes could be seen on the COM-port tester the bike can be consider being without malfunction.</p> <p>The communication problems is probably caused by the PC where the PC program is installed. Its COM-port could be broken or has an incorrect driver. If that is the problem please contact your network administrator for control of program installations. Alternative you could try to install Monark software on a different computer. If a USB-Serial adapter used to connect the bike to a laptop, make sure the drivers are installed.</p>
<p>No RPM visible in Monark software.</p>	<ol style="list-style-type: none"> 1. Start button in Monark software has not been activated. 2. Check that the sensor on flywheel is working properly and that it is connected to the correct port on the bike's circuit board. <i>See Fig: Connections on circuit board.</i> 3. Check that the magnets on the flywheel's left side does not have fallen off. <i>See Fig: Sensor and magnets on flywheel.</i>

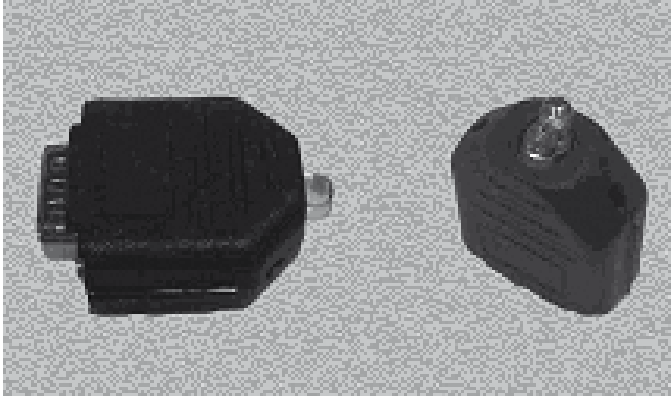

Fig: COM-port tester

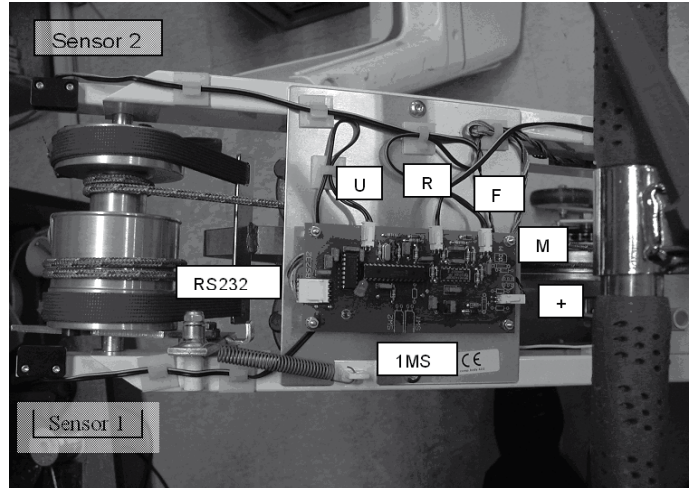

Fig: Connections on circuit board

Connector U: Sensor 1

Connector F: Sensor 2

Connector R: Sensor on flywheel

Connector +: Power supply (red/black wire)

Connector M: Magnet

Connector RS232: Communication cables (5 pcs)

Connector 1MS: Button on handlebar

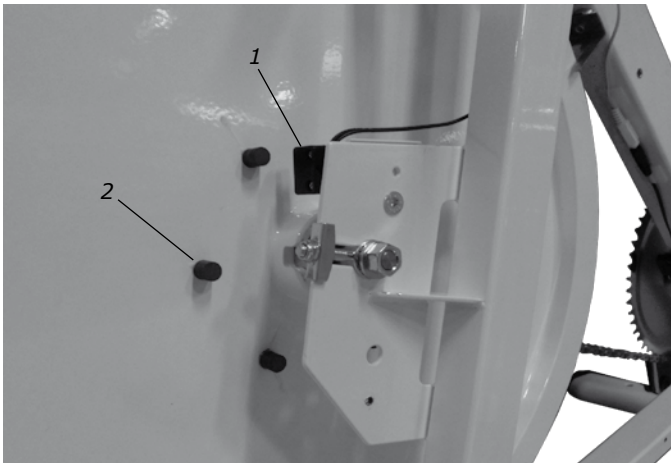

Fig: Sensor and magnets on flywheel

1) Sensor

2) Magnets (6 pcs.)

Service

Note that the text about service and maintenance is universal and that all parts may not be relevant to your bike.

Varning

Make sure the voltage indicated on the appliance corresponds to the local mains voltage before making connections.

Warranty

EU countries - Private use

If you are a consumer living in the EU you will have a minimum level of protection against defects in accordance with EC Directive 1999/44/EC. In short, the directive states for that your Monark Dealer will be liable for any defects, which existed at the time of delivery. In case of defects, you will be entitled to have the defect remedied within a reasonable time, free of charge, by repair or replacement.

EU countries - Professional use

Monark Exercise products and parts are guaranteed against defects in materials and workmanship for a period of one year from the initial date of purchase of the unit. In the event of a defect in material or workmanship during that period, Monark Exercise will repair or replace the product. Monark Exercise will not, however, refund costs for labour or shipping.

Other countries

Monark Exercise products and parts are guaranteed against defects in materials and workmanship for a period of one year from the initial date of purchase of the unit. In the event of a defect in material or workmanship during that period above, Monark Exercise will repair or replace (at its option) the product. Monark Exercise will as above for labour or shipping.

Service check and maintenance

It is important to carry out a regular service on your ergometer, to ensure it is kept in good condition.

Service action:

- If you wish to disinfect the surface of the bike we recommend isopropyl alcohol. Use a damp but not wet cloth to clean the surface you wish to disinfect.
- Keep your Ergometer clean and properly lubricated (once a week).
- Periodically wipe the surface with a rust preventative, especially when it has been cleaned and the surface is dry. This is done to protect the chrome- and zinc parts as well as the painted parts (4 times per year).
- Check now and then that both pedals are firmly tightened. If not the threading in the pedal arms will be damaged. Also check that pedal arms are firmly tightened on the crank axle, tighten if necessary. When the Ergometer is new it is important to tighten the pedals after 5 hours of pedalling (4 times per year).
- Check that the pedal crank is secure to the crank axle (4 times per year).
- Be sure that the pedals are moving smoothly, and that pedal axle is clear of dirt and fibres (4 times per year).
- When cleaning and lubricating be sure to check that all screws and nuts are properly tightened (2 times per year).
- Check that the chain is snug and there is no play in the pedal crank (2 times per year).
- Check that pedals, chain and freewheel sprocket are lubricated (2 times per year).
- Be sure that the brake belt does not show significant signs of wear (2 times per year).
- Check that the handlebars and seat adjustment screws are lubricated (2 times per year).
- Be sure that all moving parts as crank and flywheel are working normal and that no abnormal play or sound exists. I.e. play in bearings causes fast wearing and with that follows a highly reduced lifetime.
- Check that the flywheel is placed in the center and with plane rotation.

Batteries

If the meter is battery-operated, the batteries are in a separate package at delivery. If the storing time has been long the battery power can be too low to make the computer act correctly. Batteries must then be changed.

Crank bearing

The crank bearing is long term greased and require normally no supplementary lubrication. If problem arises, please contact your Monark dealer.

Flywheel bearing

The bearings in the flywheel are lifetime greased and require normally no maintenance. If problem arises, please contact your Monark dealer.

Transport

At transport the brake cord should be somewhat tightened to prevent it from falling off the flywheel.

Replacement of brake belt

To replace the brake belt remove covers if necessary. Make sure that the belt is loose.

Alt. 1: To loosen the belt on pendulum bikes with engine, connect power to the unit and raise the pendulum to 4 kp. Hold it there until brake belt is loose. Please note how the belt is assembled. Remove it from the bike. Attach the new brake belt and assemble the bike in reverse order.

Alt. 2: To loosen the brake cord on cycles with weight basket set the basket to its upper position. Loosen the lock washer that is holding the cord and remove it from the tension center. Loosen or cut of the knot in the other end of the cord and then remove the hole cord from the bike. When assembling a new brake cord, first enter one end into the hole in the tension center, and tie a knot and let the knot fall into the bigger part of the hole. Lock the end of the cord with the lock washer.

Alt. 3: To loosen the belt on other bikes, turn off all workload. Please note how the belt is assembled. Remove it from the bike. Attach the new brake belt and assemble the bike in reverse order.

NOTE!

When replacing the brake belt it is recommended to clean the brake surface. See "Brake belt contact surface".

Brake belt contact surface

Deposits of dirt on the brake belt and on the contact surface may cause the unit to operate unevenly and will also wear down the brake belt. The brake belt contact of the flywheel surface should then be ground off with fine sand paper and any dust removed with a clean dry cloth.

Remove any potential covers and all workload on the brake belt and then remove it. Grind with a fine sand paper. Grinding is easier to perform if a second individual cautiously and carefully pedals the cycle.

Irregularities on the brake belt contact surface are removed by means of a fine sand paper or an abrasive cloth. Otherwise unnecessary wear on the brake belt may occur and the unit can become noisy.

Always keep the brake belt contact surface clean and dry. No lubricant should be used. We recommend replacing the brake belt when cleaning the contact surface. In regard to assembly and adjustment of the brake belt, see "Replacement of brake belt".

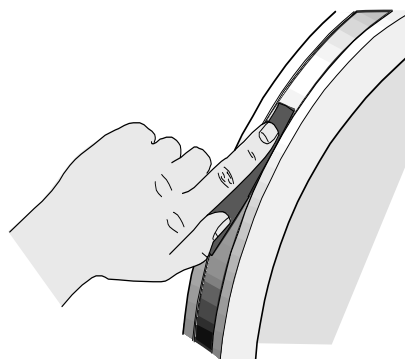

Fig: Brake belt contact surface

Chain 1/2" x 1/8"

Check the lubrication and tension of the chain in regular intervals. In the middle of its free length the chain should have a minimum play(3) of 10 mm (1/4 inch). See *Fig: Chain adjustments*. When the play in the chain is about 20 mm (3/4 inch) the chain must be tightened. Otherwise it will cause abnormal wear of the chain and sprockets. Therefore it is always recommended to keep the chain play as little as possible. Loosen the hub nut(2) on both sides and tense the chain with the chain adjuster(1) when needed.

When the chain has become so long that it can no longer be tightened with the chain adjusters it is worn out and shall be replaced with a new one.

To replace the brake belt, remove covers as required.

To adjust the chain the hub nuts(2) should be loosened. Loosening or tightening the nuts on the chain adjusters will then move the hub and axle forward or backward (1). Tighten hub nuts firmly. See *Fig: Chain adjustments*.

To replace the chain, loosen the chain adjusters as much as possible. Dismantle the chain lock(6) and remove the chain. Use a pair of tongs for dismantling spring. Put on a new chain and assemble the chain lock. The spring of the chain lock should be assembled with the closed end in the movement direction(5) of the chain. Use a pair of tongs for dismantling and assembling the spring (4). See *Fig: Chain replacement*.

NOTE! At assembly the flywheel has to be parallel with the centerline of the frame. Otherwise the chain and sprockets makes a lot of noise and wears out rapidly.

Then assemble the removed details as above but in reverse order.

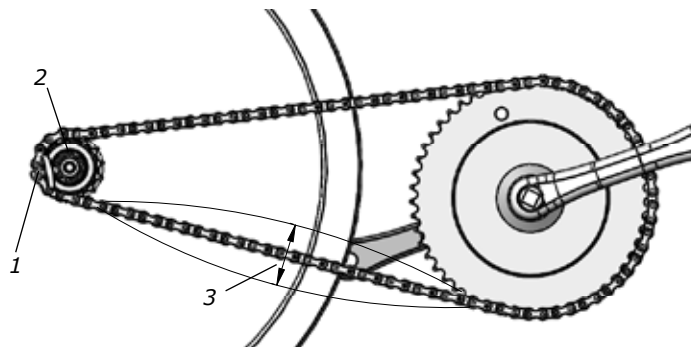

Fig: Chain adjustments
1) Chain adjuster
2) Axle nut
3) Chain play

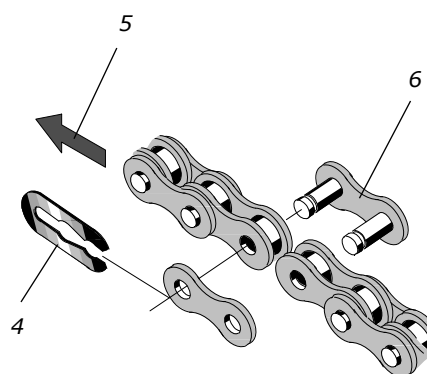

Fig: Chain replacement
4) Lock spring
5) Movement direction
6) Chain lock

Freewheel sprocket

When replacing the freewheel sprocket remove frame covers if necessary. Remove the chain according to section "Chain 1/2" x 1/8".

Loosen the axle nuts and lift off the flywheel. Remove the axle nut, washer, chain adjuster and spacer on the freewheel side. Special remover (Art. No: 9100-14) in the adapter and place the spacer and axle nut outside. See *Fig: Special remover*.

NOTE! NOTE: Do not tighten the axle nut completely. It must be possible to loosen the adapter-sprocket half a turn.

Replace sprocket-adapter and assemble the new parts in reverse order according to the above.

The sprocket should be lubricated with a few drops of oil once a year. Tilt the cycle somewhat to make it easier for the oil to reach the ball bearing. See *Fig: Lubrication*.

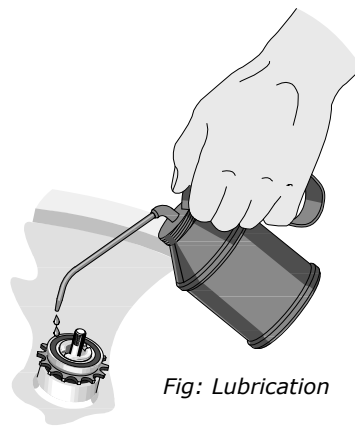

Fig: Lubrication



*Fig: Special remover
(Art. No: 9100-14)*

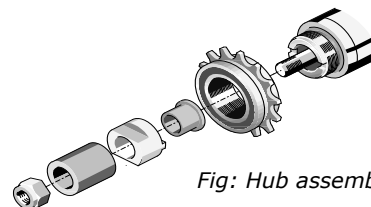
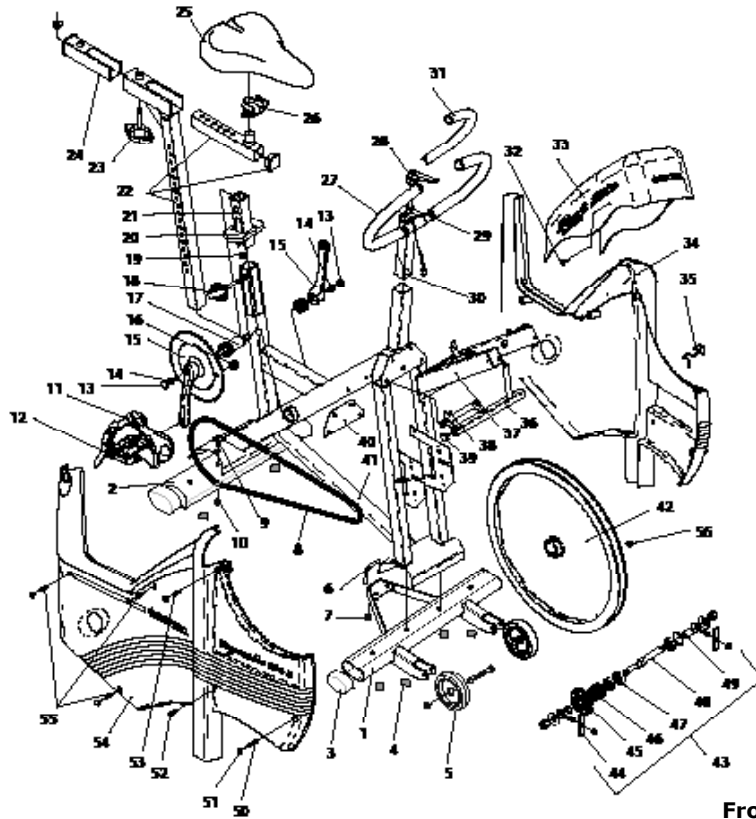

Fig: Hub assembly

Spare parts



From serial number: WBK 280889

Pos.	Qty.	Art. No.	Description	Pos.	Qty.	Art. No.	Description
1	1	9301-19	Support tube, front	30	1	9300-291	-Expander wedge
2	1	9301-14	Support tube, rear	31	1	9126-72	Handgrip, blue (pair)
3	4	9328-51	Plastic cap, blue	32	2	5675-9	Screw
4	6	9328-26	Rubber foot	33	1	9394-41	Instrument cover
5	1	9328-37	Transport wheel, (pair) compl.	34	1	9394-71	Frame cover, left
6	1	9394-13	Hoop	35	1	9384-45	Belt control
7	2	5843	Locking nut to hoop	36	1	9374-29	Weight holder
8	1	9300-55	Chain 1/2 x 1/8", 116 l	37	1	9374-9	Frame for equipment
9	2	9300-12	Screw MVBF M8x16 mm	38	2	5843-9	Locking nut M6
10	4	5845	Locking nut M8	39	2	9302-28	Plastic cap, black
11	1	8321-75	Pedal (pair)	40	1	9374-60	Bracket
12	1	8323-2	-Pedal cleats, pair, VP	41	1	9301-5	Frame
13	2	8523-2	Dust cover	42	1	9300-3	Flywheel
14	2	8523-115	Screw M6S 8.8 M8 x 20 FZB	43	1	9300-24	Wheel suspension compl. set
15	1	9300-430	Steel crank set, complete	44	1	9000-12	-Chain adjuster (pair)
16	1	9326-164	Magnet	45	1	9106-13	-Sprocket
17	1	8966-175	BB cartridge bearing	46	1	9106-14	-Connection
	1	9300-133	Locking knob, complete	47	3	19001-6	-Bearing 6001-2z
18	1	9300-122	-Locking knob	48	1	9300-18	-Axle
19	1	9300-134	-Pressure washer	49	1	9300-17	-Bush, 23 mm
20	1	9300-123	Top cover	50	1	5683	Screw
21	1	9300-115	Bushing f. saddle post	51	10	9306-12	Dust cover
22	1	9336-111	Saddle post, complete	52	1	5673-9	Screw
23	1	9300-718	-Locking screw	53	1	5681	Screw
24	1	9300-716	Bushing f. saddle post	54	1	9394-70	Frame cover, right
25	1	9334-110	Saddle	55	3	5671-19	Screw
26	1	5466	-Seat clamp	56	6	9374-16	Magnet
27	1	9300-293	Handlebar, complete with button		1	9339-98	Chestbelt
28	1	9100-180	-Screw		1	9300-365	PC program
29	1	5866	-Washer		1	9338-20	USB-Serial converter

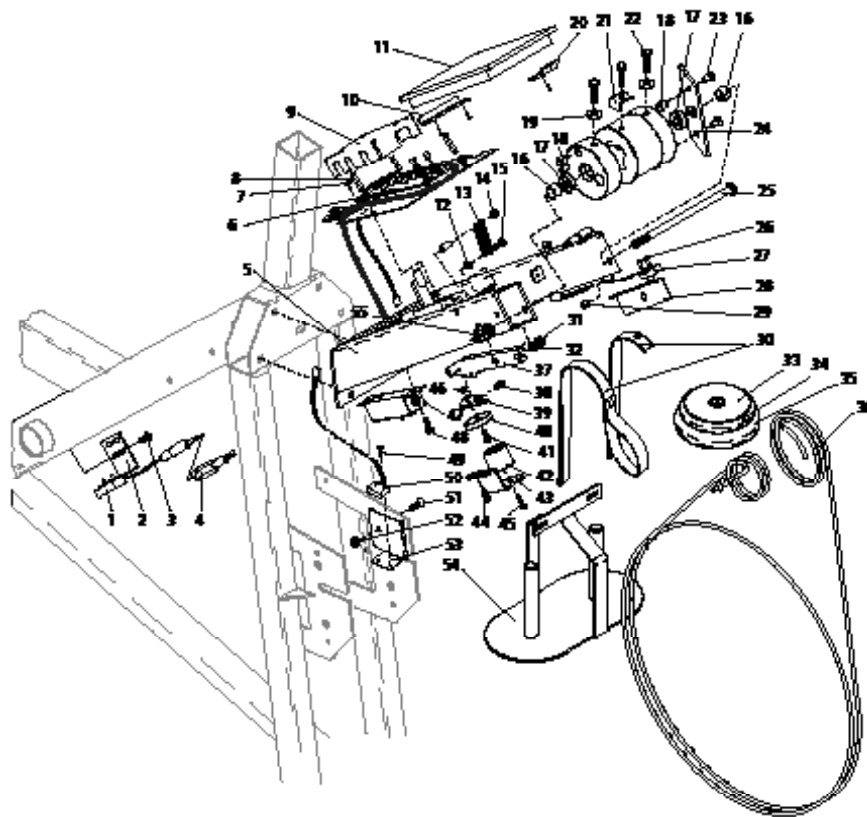

From serial number: WBK 280889

Pos.	Qty.	Art. No.	Description	Pos.	Qty.	Art. No.	Description
1	1	9326-162	Sensor	29	1	9374-12	Damper
2	1	9326-166	Holder for sensor	30	1	9324-26	Suspension belt
3	2	9326-59	Screw	31	1	5842-9	Nut
4	1	9326-263	Cable	32	1	5862	Washer
5	1	9374-9	Frame for equipment	33	4	9102-30	Weight, 0.1 kg, 0.2 lb
6	1	9394-10	Electronic set	34	1	9102-27	Weight, 0.5 kg, 0.2 lb
7	4	5675	Screw	35	8	9102-26	Weight, 1 kg, 0.2 lb
8	4	9384-432	Spacer nut	36	1	9384-47	Brake belt
9	1	9394-431	Cover for electronic set	37	1	9384-33	Magnet arm
10	1	9374-172	Bracket	38	2	5673-9	Screw M5x12
11	1	9374-170	Digital meter	39	1	9384-37	Holder
12	1	5842-9	Nut	40	1	9384-34	Plate
13	2	9384-36	Spring	41	1	L6042	Screw M5x13
14	1	5767-9	Nut	42	1	9384-32	Electro magnet
15	1	9384-3	Screw	43	1	9384-31	Magnet bracket
16	2	9127-37	Spacer	44	3	5673-9	Screw M5x12
17	2	19088-6	Bearing	45	1	5670	Screw
18	2	9374-37	Magnet	46	1	5842-9	Nut M5
19	2	5862	Washer	47	1	9374-240	Contact holder with cables
20	1	9374-171	Bracket	48	4	5675-9	Screw
21	1	9324-70	Self-locking cap	49	2	9103-41	Screw
22	3	14323	Screw	50	1	9326-169	Sensor with cable 620 mm
23	2	14379	Screw	51	1	14380	Screw
24	1	9374-21	Stop	52	1	5843-9	Nut
25	1	14374	Screw M8 160mm	53	1	9374-23	Holder for sensor
26	4	9103-41	Screw	54	1	9324-25	Weight basket
27	2	9326-270	Sensor with cable 390 mm	55	1	5844	Locking nut M8
28	2	9374-22	Holder for sensor		1	9384-650	Power adaptor/switching adaptor



Version 1207
Art. No: 7950-312

