

**BLADEZ**<sup>®</sup>  
F I T N E S S

# Master GS

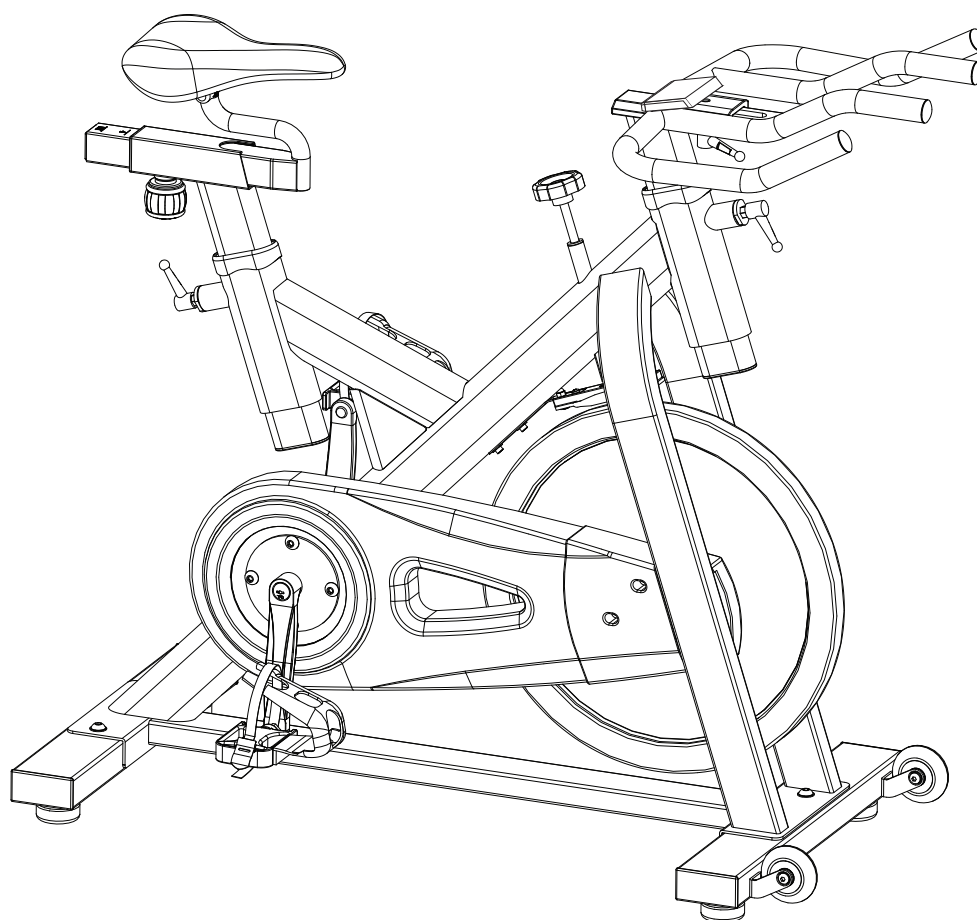

## OWNER'S MANUAL

*Important: Read all instructions carefully before using this product. Retain this owner's manual for future reference.*

BH North America | 20155 Ellipse, Foothill Ranch, California 92610 | p.949.206.0330 | f.949.206.0013 | [www.bhnorthamerica.com](http://www.bhnorthamerica.com)

# BLADEZ<sup>®</sup>

F I T N E S S

## TABLE OF CONTENTS

<b>Title</b>	<b>Page</b>
Introduction	03
Safety Information	04
Exercise Instruction	05
Training Guidelines	06
Suggested Stretches	10
Assembly Instructions	12
Console Operations	19
Maintenance and Cleaning	21
Exploded View Drawing	22
Parts List	23
Warranty	24

## CONGRATULATIONS

Congratulations on your purchase of Bladez Fitness equipment. We hope you appreciate the style, quality, and value that exercisers around the world have come to expect from Bladez Fitness.

If you have any questions, concerns or product issues please call our Customer Service Team at 1-866-325-2339 or email us at [CustomerSupport@BHNorthAmerica.com](mailto:CustomerSupport@BHNorthAmerica.com).

Carefully read through the instructions contained in this manual. They provide you with important information about assembly, safety, fitness and use of the machine. Please read ALL the safety information contained on the following page.

# SAFETY INFORMATION

## PRECAUTIONS

This equipment has been designed and constructed to provide maximum safety. Nevertheless, certain precautions should be taken when using exercise equipment. Read the whole manual before assembling and using the machine. Please observe the following safety precautions:

1. Keep children and pets away from this equipment at all times. DO NOT leave them unsupervised in the room where the machine is kept.
2. If you experience dizziness, nausea, chest pains or any other symptom while using this machine STOP the exercise. SEEK IMMEDIATE MEDICAL ATTENTION!
3. Use the machine on a level and solid surface. Adjust the feet for stability.
4. Keep your hands away from any of the joints and moving parts.
5. Wear clothing suitable for doing exercise. Do not wear baggy clothing that might get caught in the machine. Always wear athletic shoes when using the machine and tie the laces securely.
6. This machine must only be used for the purposes described in this manual. DO NOT use accessories that are not recommended by BH Fitness. Read manual prior to use and follow all warnings and instructions.
7. Do not place sharp objects near the machine.
8. Any person with physical or coordination limitations should not use the machine without the assistance of a qualified person or doctor. Misuse of this machine may result in serious injury.
9. Do warm-up stretching exercises before using the equipment.
10. Do not use the machine if it is not working correctly.
11. Before using the machine, thoroughly inspect the equipment for proper assembly.
12. Keep a perimeter of 3 feet (1 meter) around the machine before operating the equipment.
13. Use only authorized and trained technicians if a repair is needed.
14. Please follow the advice for correct training, as detailed in the Training Guidelines.
15. Use only the tools provided to assemble this machine.
16. Replace warning labels if damaged, illegible or removed.
17. This machine was designed for a maximum user weight of 300 lbs (136 kgs)
18. The machine can only be used by one person at a time.

**Caution:** Consult your doctor before beginning to use the machine or any exercise program. Read all of the instructions before using any exercise equipment.

KEEP THESE INSTRUCTIONS SAFE FOR FUTURE USE.

## EXERCISE INSTRUCTION

Use of the machine offers various benefits; it can improve fitness, muscle tone and when used in conjunction with a calorie controlled diet, it can help you lose weight.

1. Consult your doctor before starting any exercise program. It is advisable to undergo a complete physical examination.
2. Work at the recommended exercise level. Do not over exert yourself.
3. If you feel any pain or discomfort, stop exercising immediately and consult your doctor.
4. Wear appropriate clothing and footwear for the exercise; do not wear loose clothing; do not wear leather soled shoes or footwear with high heels.
5. It is advised that you do warm-up stretches before working out.
6. Get on the equipment slowly and securely.
7. Select the program or workout option that is most closely aligned with your workout interests.
8. Start slowly and work your way up to a comfortable pace.
9. Be sure to cool down after your workout.

## TRAINING GUIDELINES

Exercise is one of the most important factors in the overall health of an individual. Listed among its benefits are:

- Increased capacity for physical work (strength endurance)
- Increased cardiovascular (heart and arteries/veins) and respiratory efficiency
- Decreased risk of coronary heart disease
- Changes in body metabolism, e.g. losing weight
- Delaying the physiological effects of age
- Reduction in stress, increase in self-confidence, etc.

There are several components of physical fitness and each is defined below.

### *STRENGTH*

The capacity of a muscle to exert a force against resistance. Strength contributes to power and speed.

### *MUSCULAR ENDURANCE*

The capacity to exert a force repeatedly over a period of time, e.g. it is the muscular endurance of your legs to carry you 10 km without stopping.

### *FLEXIBILITY*

The range of motion of your joints. Improving flexibility involves the stretching of muscles and tendons to maintain or increase suppleness, and it provides increased resistance to muscle injury or soreness.

### *CARDIO-RESPIRATORY ENDURANCE*

The most essential component of physical fitness. It is the efficient functioning of the heart and lungs.

### *AEROBIC FITNESS*

Is an exercise of relatively low intensity and long duration, which depends primarily on the aerobic energy system. Aerobic means "with oxygen", and refers to the use of oxygen in the body's metabolic or energy-generating process. Many types of exercise are aerobic, and by definition are performed at moderate levels of intensity for extended periods of time.

### *ANAEROBIC TRAINING*

Is an exercise intense enough to trigger anaerobic metabolism. This means "without oxygen" and is the output of energy when the oxygen supply is insufficient to meet the body's long term energy demands. (For example, a 100 meter sprint.)

### *OXYGEN UPTAKE*

The effort that you can exert over a prolonged period of time is limited by your ability to deliver oxygen to the working muscles. Regular vigorous exercise produces a training effect that can increase your aerobic capacity by as much as 20 to 30%. An increased VO2 Max indicates an increased ability of the heart to pump blood, of the lungs to ventilate oxygen, and of the muscles to take up oxygen.

### *THE TRAINING THRESHOLD*

This is the minimum level of exercise which is required to produce significant improvements in any physical fitness parameter.

### *OVERLOAD*

This is where you exercise above your comfort level. The intensity, duration and frequency of exercise should be above the training threshold and should be gradually increased as the body adapts to the increasing demands. As your fitness level improves, the training threshold should rise. Working through your program and gradually increasing the overload factor is important.

### *PROGRESSION*

As you become more fit, a higher intensity of exercise is required to create an overload and therefore provide continued improvement.

### *SPECIFICS*

Different forms of exercise produce different results. The type of exercise that is carried out is specific to the muscle groups being used and to the energy source involved. There is little transfer of the effects of exercise, i.e. from strength training to cardiovascular fitness. That is why it is important to have an exercise program tailored to your specific needs.

### *REVERSIBILITY*

If you stop exercising or do not do your program often enough, you will lose the benefits you have gained. Regular workouts are the key to success.

### *WARM-UP*

Every exercise program should start with a warm-up where the body is prepared for the effort to come. It should be gentle and preferably use the muscles group to be involved later. Stretching should be included in both your warm-up and cool down, and should be performed after 3-5 minutes of low intensity aerobic activity or calisthenic type exercise.

### *WARM DOWN OR COOL DOWN*

This involves a gradual decrease in the intensity of the exercise session. Following exercise, a large supply of blood remains in the working muscles. If it is not returned promptly to the central circulation, pooling of blood may occur in the muscles.

### *HEART RATE*

As you exercise, your heart beat increases. This is often used as a measure of the required intensity of an exercise. You need to exercise hard enough to condition your circulatory system, and increase your pulse rate, but not enough to strain your heart.

Your initial level of fitness is important when developing an exercise program for you. When starting, you can get a good training effect with a heart rate of 110-120 beats per minute (BPM). If you are more fit, you will need a higher threshold of stimulation.

To begin with, you should exercise at a level that elevates your heart rate to about 65 to 70% of your maximum. If you find this is too easy, you may want to increase it, but it is better to lean on the conservative side.

As a rule of thumb, the maximum heart rate is 220 minus your age. As you increase in age, your heart, like other muscles, loses some of its efficiency. Some of its natural loss is won back as fitness improves. The following table is a guide to those who are “starting fitness.”

Age Target Heart Rate	25	30	35	40	45	50	55	60	65
10 Second Count	23	22	22	21	20	19	19	18	18
Beats per Minute	138	132	132	126	120	114	114	108	108

### *PULSE COUNT*

The pulse count (on your wrist or carotid artery in the neck, taken with two index fingers) is done for ten seconds, taken a few seconds after you stop exercising. This is for two reasons: (a) 10 seconds is long enough for accuracy, (b) the pulse count is to approximate your BPM rate at the time you are exercising. Since heart rate slows as you recover, a longer count isn't as accurate.

The target is not a magic number, but a general guide. If you're above average with your fitness, you may work comfortably a little above that suggested for your age group. The following table is a guide.

Age Target Heart Rate	25	30	35	40	45	50	55	60	65
10 Second Count	26	26	25	24	23	22	22	21	20
Beats per Minute	156	156	150	144	138	132	132	126	120

Don't push yourself too hard to reach the figures on this table. It can be very uncomfortable if you over exercise. Let it happen naturally as you work through your program. Remember, the target is a guide, not a rule, a little above or below is just fine.

Two final comments: (1) don't be concerned with day to day variations in your pulse rate, being under pressure or not enough sleep can affect it; (2) your pulse rate is a guide, don't become a slave to it.



### *MUSCLE SORENESS*

For the first week or so, muscle soreness may be the only indication you have that you are on an exercise program. This, of course, does depend on your overall fitness level. A confirmation that you are on the correct program is a very slight soreness in most major muscle groups. This is quite normal and will disappear in a matter of days.

If you experience major discomfort, you may be on a program that is too advanced, or you have increased your program too rapidly.

If you experience PAIN during or after exercise, your body is telling you something. Stop exercising and consult your doctor.

### *WHAT TO WEAR*

Wear clothing that will not restrict your movement in any way while exercising. Clothes should be light enough to allow the body to cool. Excessive clothing that causes you to perspire more than you normally would gives you no advantage. The extra weight you lose is body fluid and will be replaced with the next glass of water you drink. Always wear a pair athletic shoes.

### *BREATHING DURING EXERCISE*

Do not hold your breath while exercising. Breathe normally as much as possible. Remember, breathing involves the intake and distribution of oxygen, which feeds the working muscles.

### *REST PERIODS*

Once you start your exercise program, you should continue through to the end. Do not break off halfway through and then restart at the same place later on without going through the warm-up stage again. The rest period required between exercises may vary from person to person.

## SUGGESTED STRETCHES

### *Head Rolls*

Rotate your head to the right for one count while feeling the stretch up the left side of your neck. Next, rotate your head back for one count, stretching your chin to the ceiling. Rotate your head to the left for one count, and finally, drop your head to your chest for one count.

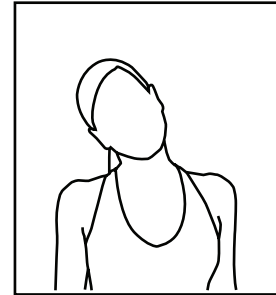

### *Shoulder Lifts*

Lift your left shoulder up toward your ear for one count. Then lift your right shoulder up for one count as you lower your left shoulder.

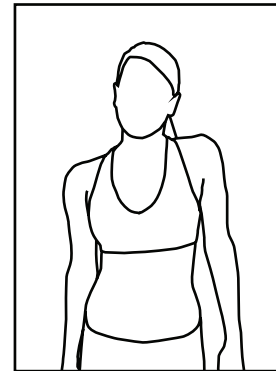

### *Side Stretches*

Open your arms to the side and continue lifting them until they are over your head. Reach your left arm as far upward as you can for one count. Feel the stretch up your left side. Repeat this action with your right arm.

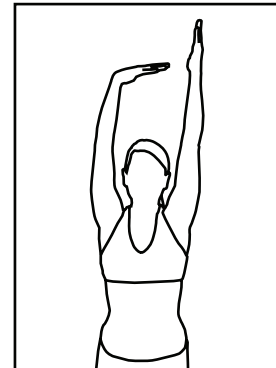

### *Quadriceps Stretch*

With one hand against a wall for balance, reach behind you and pull your left foot up. Bring your heel as close to your buttocks as possible. Hold for 15 counts and repeat with right foot up.

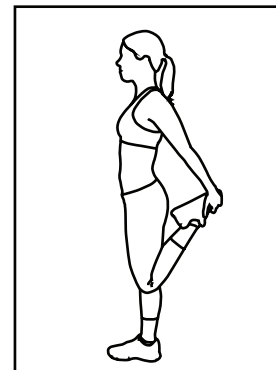

## SUGGESTED STRETCHES

### *Inner Thigh Stretch*

Sit with the soles of your feet together with your knees pointing outward. Pull your feet as close into your groin as possible. Gently push your knees towards the floor. Hold for 15 counts.

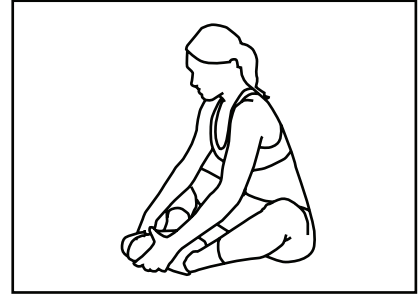

### *Toe Touches*

Slowly bend forward from your waist, letting your back and shoulders relax as you stretch toward your toes. Reach down as far as you can and hold for 15 counts.

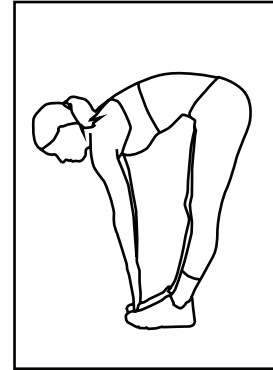

### *Hamstring Stretches*

Sit with your right leg extended. Rest the soles of your left foot against your right inner thigh. Stretch toward your toes as far as possible. Hold for 15 counts. Relax and then repeat with left leg extended.

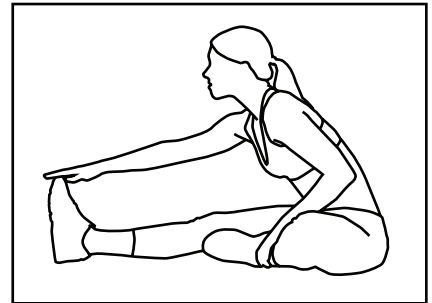

### *Calf/Achilles Stretches*

Lean against a wall with your right leg in front of the left and your arms forward. Keep your left leg straight and the right foot on the floor; then bend the right leg and lean forward by moving your hip toward the wall. Hold, then repeat on the other side for 15 counts.

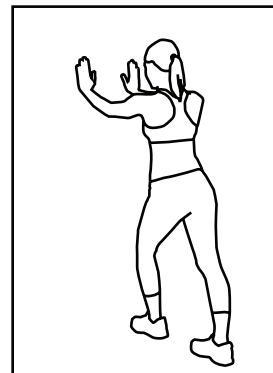

# ASSEMBLY INSTRUCTIONS

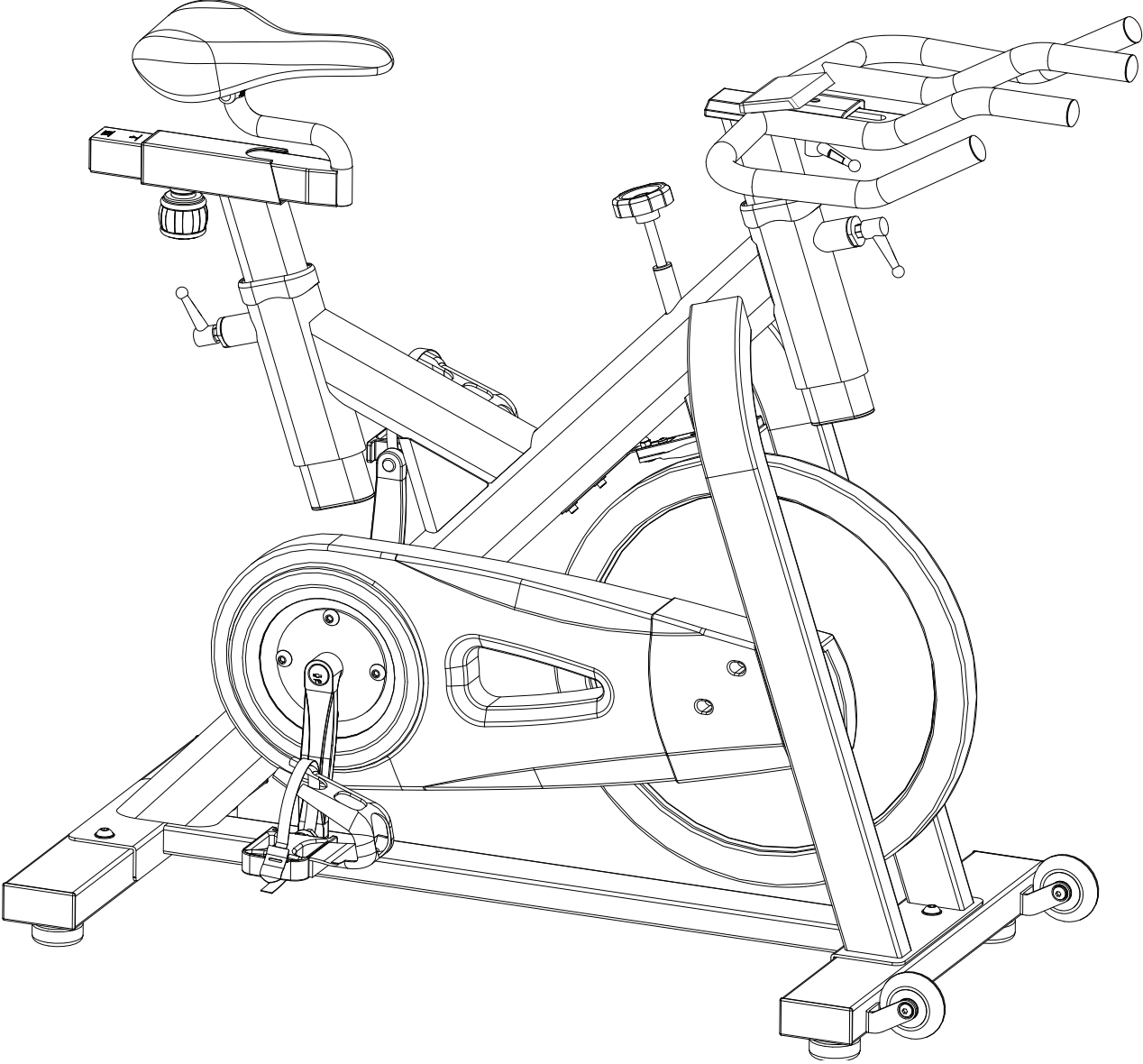

## STEP 1

### ASSEMBLE FRONT AND REAR

Follow the figure below, attach the Front Stabilizer (8) and Rear Stabilizer (7) under the Main Frame (1) with 4 pcs of Button Head Hex Socket Bolts M10\*25L(34), 4 pcs of Flat Washer 20\*10\*1.5(33) by using the supplied Allen Wrench for fastening.

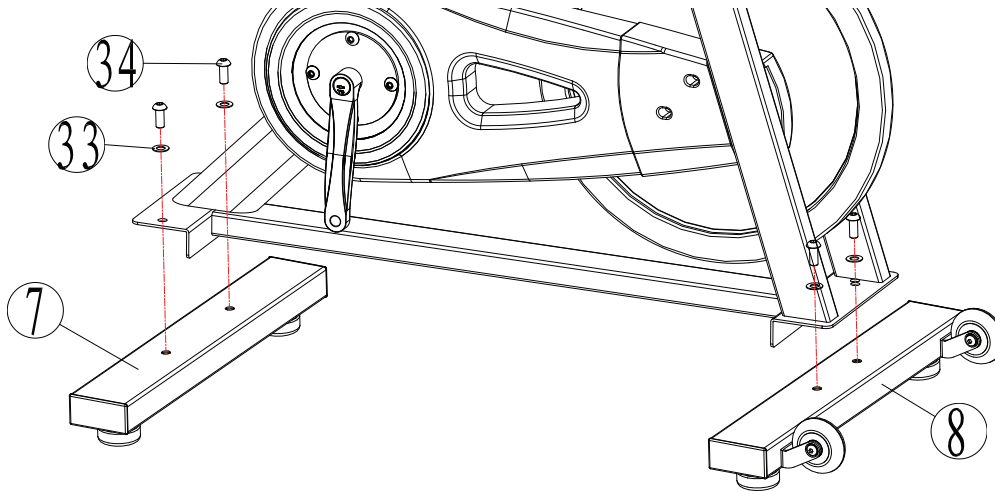

## STEP 2

### INSTALL LEFT AND RIGHT PEDALS

Refer to the figure on right, thread the Left Pedal (35-L) and Right One (35-R) into the Cranks. Tighten them with Open Wrench #15. Tighten in counter clockwise direction for left pedal and clockwise direction for right pedal.

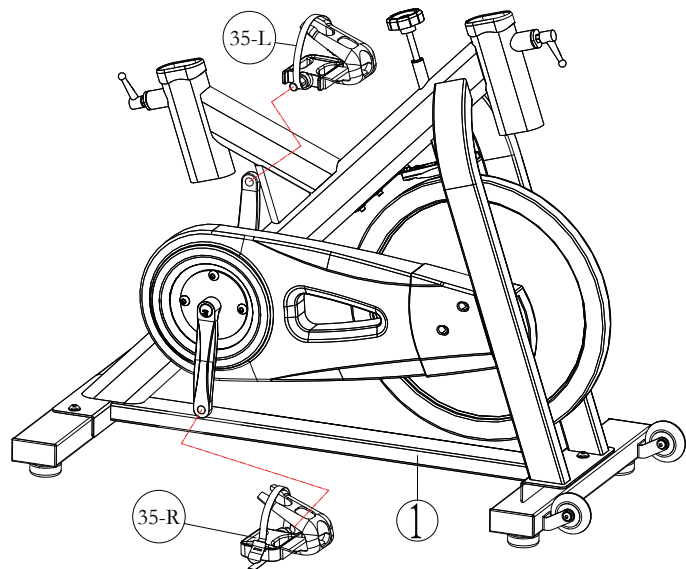

**STEP 3**  
**ASSEMBLE THE HANDLEBAR POST**

Follow the figure, loosen the L-Shaped Handle (66-A), and slide the Handlebar Post (4) into the housing on the Main Frame (1), and re-tighten the Handle (66-A).

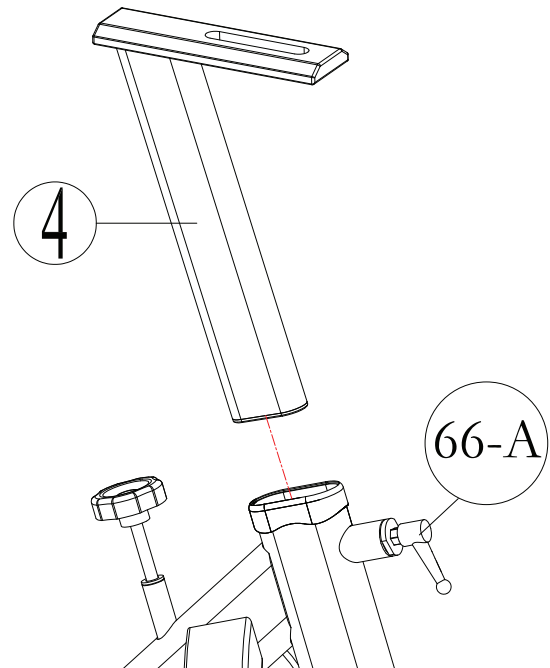

**STEP 4**  
**ASSEMBLE THE HANDLEBAR**

Attach the Handlebar (5) to the Handlebar Post and tighten it with the ratcheting L-Shaped Handle M10\*25L (66-B) and Flat Washer (bigger and thicker)  $\phi 30 * \phi 10.5 * 4T$  (67).

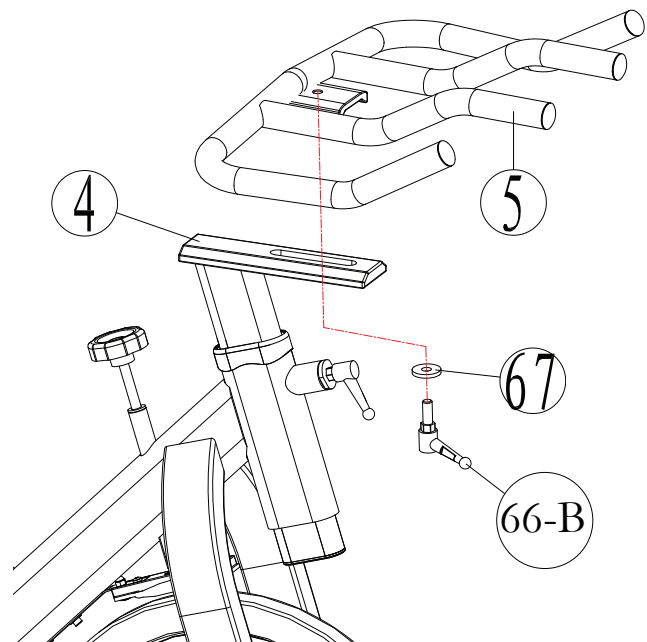

## STEP 5

### ASSEMBLE THE SEAT POST

Loosen the L-Shaped Handle (66-C) and slide the Seat Post (2) into the housing on the Main Frame, then re-tighten the Handle (66-C).

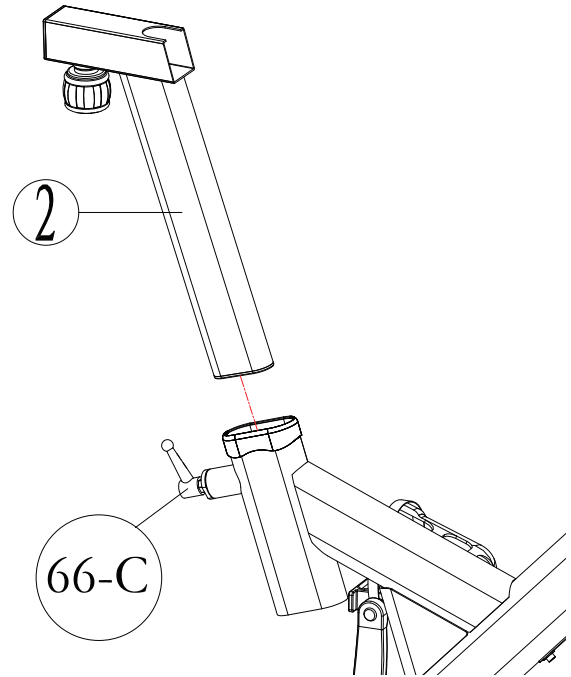

## STEP 6

### ASSEMBLE THE SEAT

Loosen the Pop Pin (23) and slide the Seat Slider (3) into the Seat Post (2), then re-tighten the Pop Pin (23) and attach the Seat (22) to the Seat Slider (3).

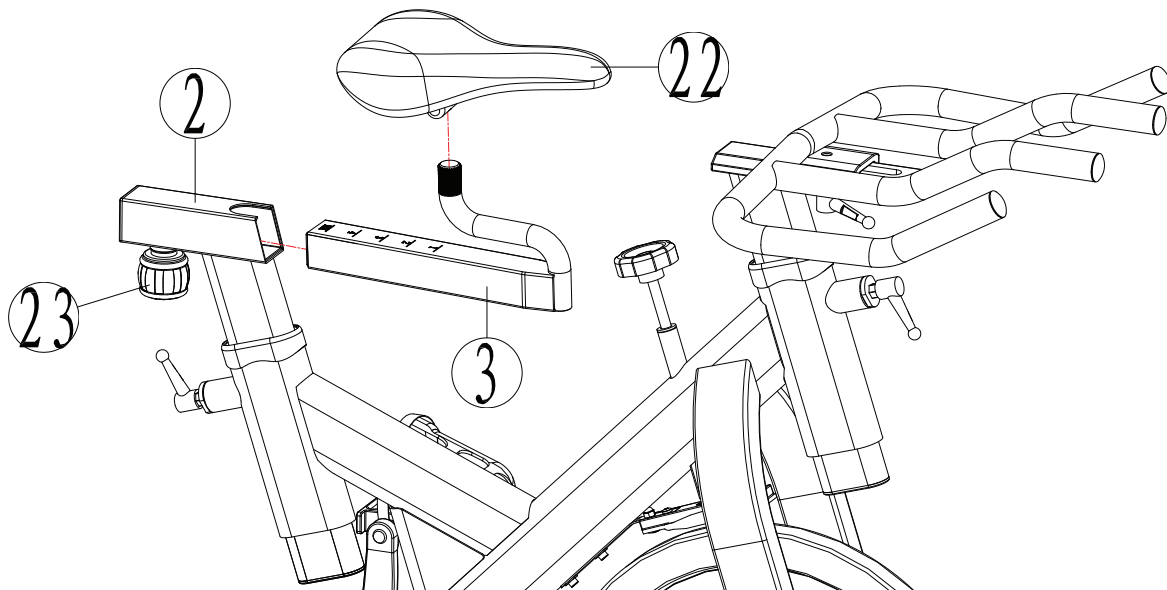

## STEP 7

Attach the computer holder onto the handlebar (5) then attach the computer (80) to the computer holder. Insert the computer cable into the jack on the side of the computer.

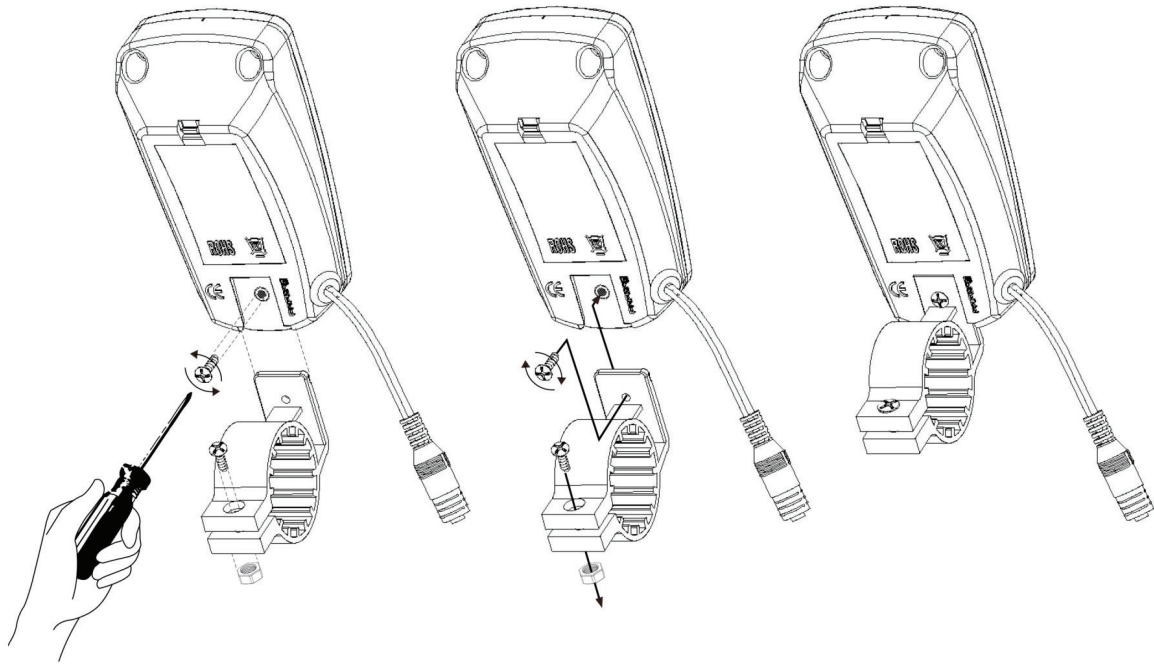



## STEP 8 SAFETY INSPECTION

Before finishing installation, please inspect all the screws and nuts carefully to make sure all of them tightened.

### NOTICE

1. Inspect all the Nuts, Nut Caps and Pedals and re-tighten as needed regularly and inspect the equipment periodically. Should you find any defective parts, replace them immediately. Don't exercise until they are repaired well.
2. Pay more attention to normal wear on parts. As in the following figure, please inspect the Leather Brake pad (24) to make sure that it is in good working condition before exercise. If it is not, please replace it.

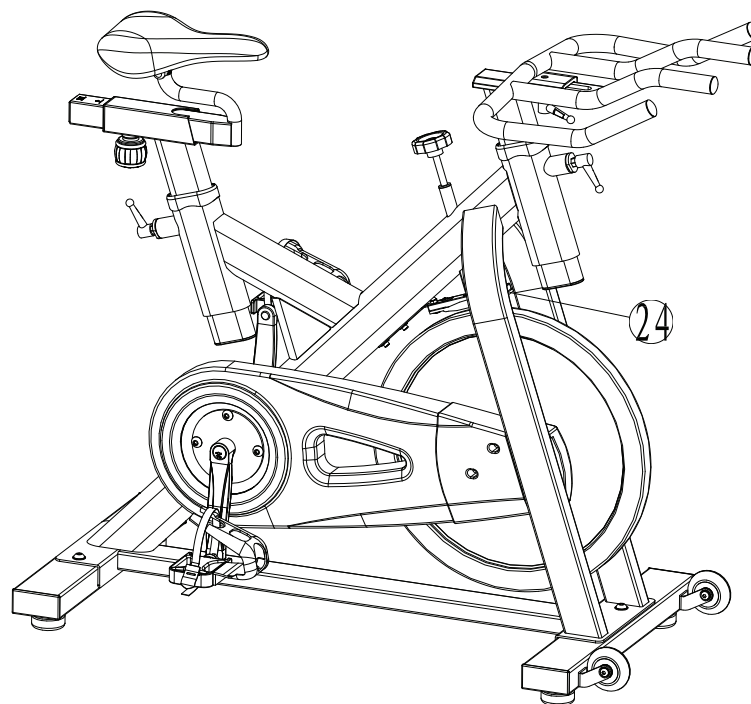

3. Before exercise, please inspect the Pedals to make sure that they are not loose, please repeat installation Step 2 if they are loose.
4. Please adjust the Hexagon Nut by using the Open Wrench if the Seat (22) is loose.

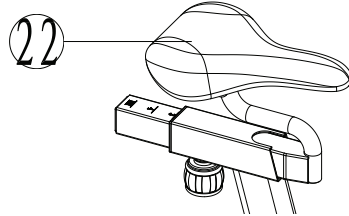

5. If you need to move the bike, use the tips of the Handlebar (5) and tilt the bike forward onto the wheels (21) and push or pull.

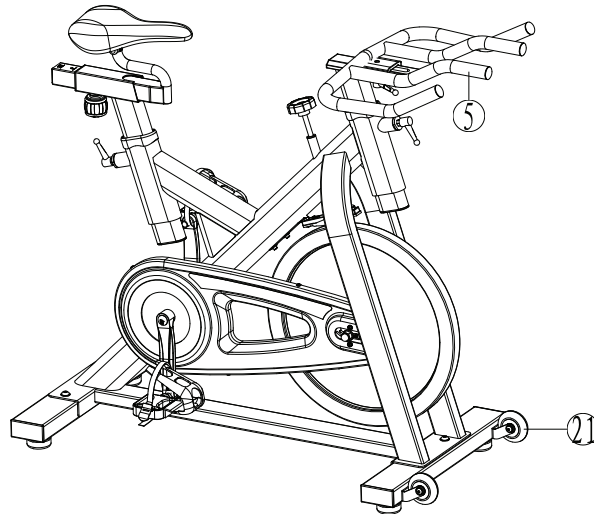

## CONSOLE OVERVIEW



## CONSOLE OPERATIONS

### GENERAL:

This console has an LCD which displays; Speed, RPM, Calories, Distance, Time and Pulse (optional).

### POWER ON/OFF

The display will show all data upon pedaling. Once pedaling stops, the LCD will blink, displaying the latest data before pedaling stopped. The display will turn off once pedaling has stopped for over 45 seconds.

### DISPLAY DATA:

#### A. SPEED

Located on top of the LCD display. Shows current speed with pointer.

#### TIME

Shows total time of the workout. Range: 00:00-99:59

#### B. RPM

Rotation Per Minute. Range: 0-140. If RPM exceeds 140, LCD will show STOP as a safety reminder.

#### C. CALORIES

Shows calories consumed during workout. Range: 000.0-999.9.

#### D. DISTANCE

Range: 0-999.9; Change increment: 0.1 miles.

#### E. PULSE

When using a compatible wireless heart rate chest strap, the bottom of the LCD will show heart rate (chest strap not included). Range: 60- 240 BPM.

## MAINTENANCE AND CLEANING

Care has been taken to assure that your equipment has been properly adjusted and lubricated at the factory. It is not recommended that the user attempt service on the internal components. Instead, seek service from an authorized service center. However, you may clean the outer surface. Use a soft cloth, dampened with warm water. Do not use aerosol sprays or pump bottles as they may deposit sediments upon the console surface. The use of harsh chemicals will destroy the protective coating and cause a static build-up that may damage the some of the components.



## PARTS LIST

**To order replacement parts: provide your customer service representative with the product model number and the part number located on the Parts List below, along with the quantity you require.**

NO.	DESCRIPTION	QTY.
1	Main Frame	1
2	Seat Post	1
3	Seat Slider	1
4	Handlebar Post	1
5	Handlebar	1
6	Cap Nut	1
7	Rear Base	1
8	Front Base	1
9	Tensioner Knob	1
10	Tension Bracket welding	1
11	Plastic sleeve	1
12	R/L Crank	1 set
13	Phillips Self-Tapping Screw	8
14	Chain Cover A	1
15	Chain Cover B	1
16	Base Leveler	4
17	Plastic Sheath –Inner Pipe(long)	1
18	Stabilizer Cap	4
19	Seat Slider Cap	1
20	Front Cover	1
21	Pulley	2
22	Seat	1
23	Pop Pin	1
24	Leather Brake Pad	1
25	Brake Soft Mat	1
26	Plastic Mat – Chain Cover	2
27	Sheet Metal Screw Clip	1
28	Belt	1
29	Flat Washer	1
30	Axes Welding	1
31	Plastic washer	1
32	Crank Cover	2
33	Flat Washer	4
34	Button Hex Socket Head Screw	4
35	Right & Left Pedal	1set
36	Flywheel	1
37	Flywheel Spindle	1
38	PK Belt wheel	1
39	Sleeve	1
40	Tension Spring	1

NO.	DESCRIPTION	QTY.
41	Pully Flywheel-Front Drive	1
42	Brake Holder	1
43	Spring Slice	1
44	Bearing 6001	2
45	Bearing 6004	2
46	Bearing 608	4
47	Brake Thread Rob	1
48	C-shaped Buckle	2
49	Hexagon Bolt	5
50	Inner Hexagon Hollow Bolt	2
51	Brake Adjusting Nut	1
52	Washer	2
53	Inner Hexagon Flange Bolt	2
54	Cross Recessed Countersunk Bolt	2
55	Hexagon Thin Bolt	3
56	C-shaped Buckle	1
57	Hexagon Flange Bolt	1
58	Nylon Nut	1
59	Cross Recessed Pan Head Bolt	2
60	Inner Hexagon Flat Round Head Bolt	2
61	Pedal House	2
62	String - Pedal	2
63	Plastic Sheath – Inner Pipe	2
64	Phillips Screws	1
65	Cap Nut	2
66	Handle	3
67	Flat Mat (bigger and thicker)	1
68	Outer Hexagon Bolt	2
69	Washer(Bigger)	2
70	Washer	1
71	Cap Nut	1
72	Phillips Screws	2
73	Inner Hexagon Flat Round Head Bolt	1
74	Washer	1
75	Inner Hexagon Flat Round Head Bolt	4
76	Inner Screw Cap	2
77	Inner Screw Cap	2
78	Limited bearing	2
79	Spring	2
80	Computer Console	1

## WARRANTY

### LIMITED RESIDENTIAL WARRANTY

BH North America will repair or replace, free of charge, at its option, parts that are defective as a result of material or workmanship. Lifetime replacement warranty coverage on frame and one (1) year on other parts. Labor warranty coverage is one (1) year. Warranty covers the original consumer purchaser only.

### THIS WARRANTY DOES NOT COVER

- Pre-delivery set-up.
- Components that require replacement due to dirt or lack of regular maintenance.
- Expendable items which become worn during normal use.
- Repairs necessary because of operator abuse or negligence or the failure to operate and maintain the equipment according to the instructions contained in the Owner's Manual.

Register your product warranty easily online at:

<http://www.bhnorthamerica.com/BHFH/support/warranty/registration.php>

**FOR WARRANTY REPAIRS, PLEASE DO NOT TAKE YOUR MACHINE  
BACK TO THE RETAIL STORE. CONTACT BH FITNESS FIRST.**

BH Fitness/BH North America Corporation

20155 Ellipse

Foothill Ranch, CA 92610

Phone: 949.206.0330; Toll Free: 866.325.2339; Fax: 949.206.0013

Email: [fitness@bhnorthamerica.com](mailto:fitness@bhnorthamerica.com)

Web: [www.bhnorthamerica.com](http://www.bhnorthamerica.com)

Mon - Fri 8am - 5pm PST