



4 DC

METAL RETRO GLIDER (Red Coral)

MODEL: 71550

NEED ASSISTANCE ?

Call 4D CONCEPTS directly for parts or assembly assistance.

Individual stores do not stock parts

Call our Toll-free number 5 days a week except holidays:

Monday through Friday 8.00am to 5.00pm

Pacific Standard Time

1-888-310-4DCO or 1-888-310 4326

IMPORTANT: Before calling please have the model number and the packing code number ready for our customer service representatives.

You will find the model number printed on the carton label and the packing code printed in black ink on the side of the carton.

Model 71550 Packing code

It is important that you retain the model number and the packing code along with the original receipt of purchase for future reference.

Made in China

www.4dconceptsusa.com

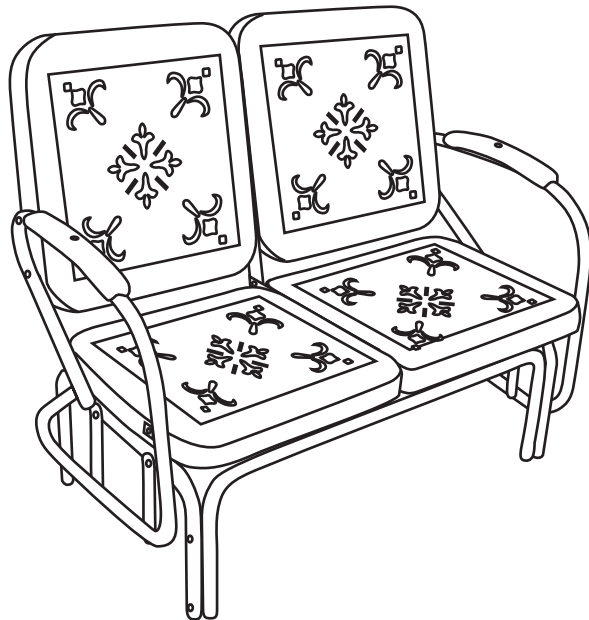









Dimensions:

42"(L) x 27"(W) x 35.5"(H)

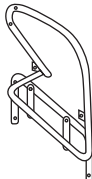
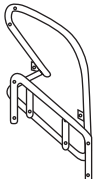
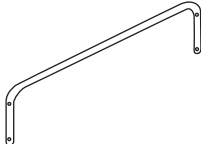
71550 ASSEMBLY INSTRUCTION

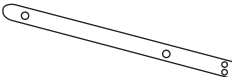
PARTS LIST:

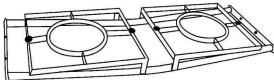

<p>(A) Right Back Qty: 1</p> 	<p>(B) Left Back Qty: 1</p> 	<p>(C) Right Seat Qty: 1</p> 	<p>(D) Left Seat Qty: 1</p> 	<p>(E) Right Arm Qty: 1</p> 
<p>(F) Left Arm Qty: 1</p> 	<p>(G) Connecting Tube Qty: 2</p> 	<p>(H) Flat Metal Bar with Hook (for Seat) Qty: 1</p> 	<p>(I) Flat Metal Bar (for Back) Qty: 1</p> 	<p>(J) Arm Cover Qty: 2</p> 
<p>(K) Seat Frame Support Qty: 1</p> 				

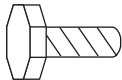
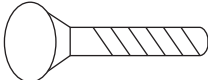
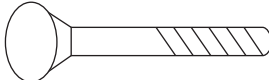
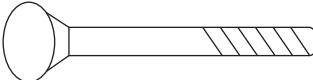
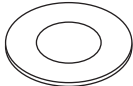
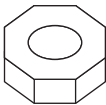
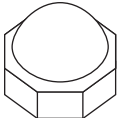
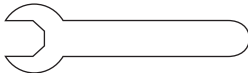
HARDWARE LIST:

<p>1. Bolt Qty: 14 6 x 15 mm</p> 	<p>2. Bolt Qty: 4 6 x 35 mm</p> 	<p>3. Bolt Qty: 2 6 x 48 mm</p> 	<p>4. Bolt Qty: 8 6 x 55 mm</p> 
<p>5. Washer Qty: 38</p> 	<p>6. Nut Qty: 22</p> 	<p>7. Round top nut Qty: 2</p> 	<p>8. Spanner Qty: 1</p> 

ATTENTION : DO NOT TIGHTEN ALL OF THE NUTS UNTIL THE FINAL STEP IS COMPLETED. IMPORTANT TO FULLY TIGHTEN BEFORE SITTING ON CHAIR.

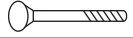
Step 1

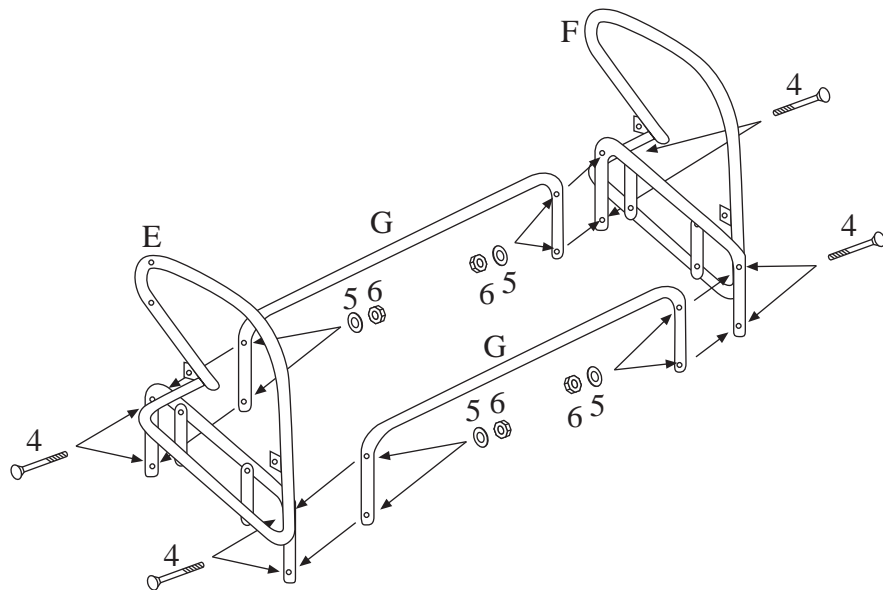

Item	Drawing	Qty
4		8
5		8
6		8



Attach the two side frames on connecting tube (G) on both sides with bolt (4) on the outside, washer (5) and nut (6) on the inside. Assembles as shown.

The best assembly way is to attach one arm side frame to both connecting tubes (G) first. After fixing, attach another arm side frame to both connecting tubes (G).

Step 2

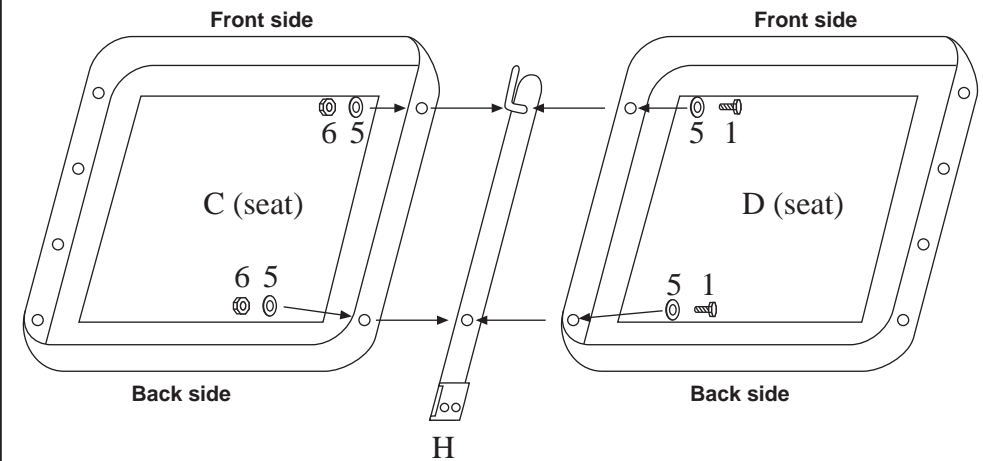
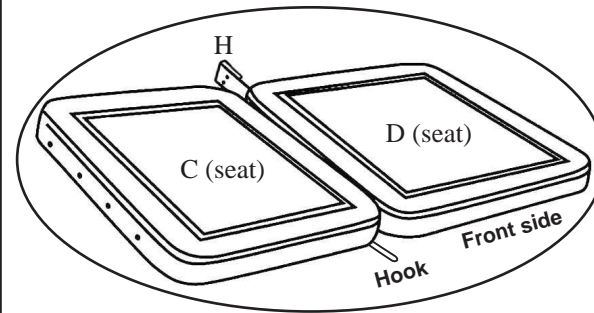

Item	Drawing	Qty
1		2
5		4
6		2



Place the flat metal bar (H) with hook in one end and connect two seat panels with bolt (1) and washer (5) and nut (6) on other side.

ATTENTION : DO NOT TIGHTEN ALL OF THE NUTS UNTIL THE FINAL STEP IS COMPLETED. IMPORTANT TO FULLY TIGHTEN BEFORE SITTING ON CHAIR.

Step 3

Item	Drawing	Qty
1		4
5		8
6		4

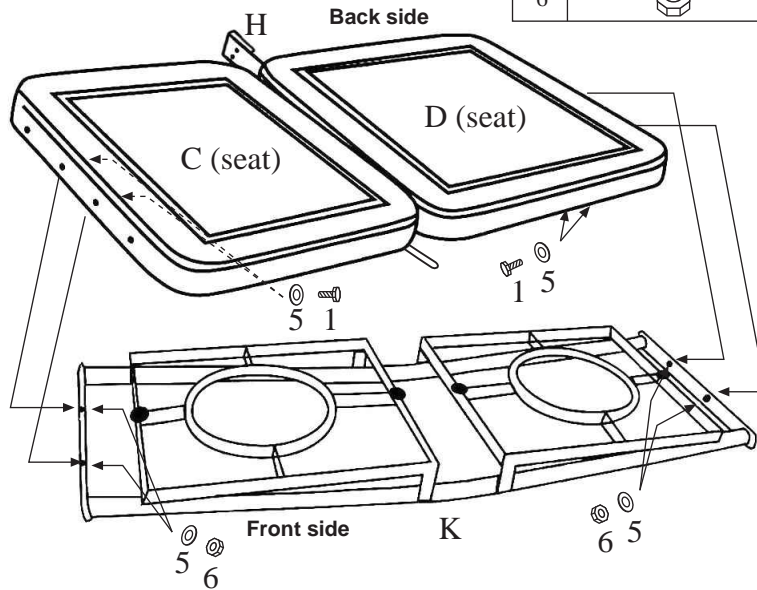

Turn the connected seat panel over and place the seat frame support (K) on the bottom of the seat as shown in diagram. Secure the seat frame support with the seat panel with bolt (1), washer (5) and nut (6).

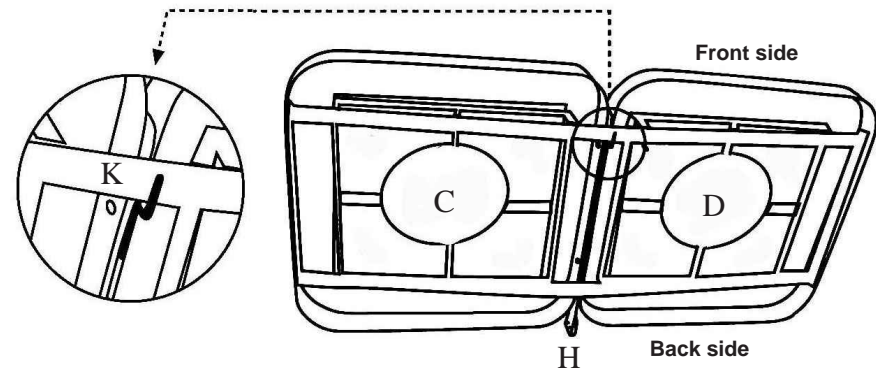

Step 4



Attach the seat bottom to the hooks of the support frame.

ATTENTION : DO NOT TIGHTEN ALL OF THE NUTS UNTIL THE FINAL STEP IS COMPLETED. IMPORTANT TO FULLY TIGHTEN BEFORE SITTING ON CHAIR.

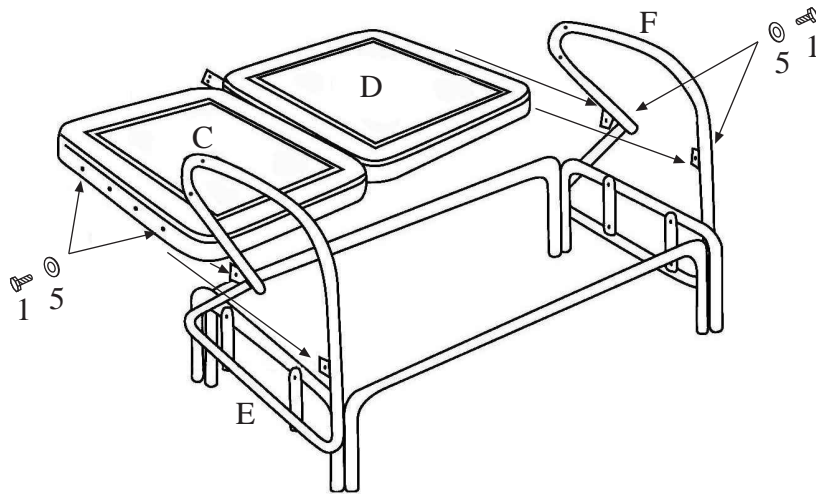

Step 5

Item	Drawing	Qty
1		4
5		4



Attach the seat bottom on arms with bolt (1) and washer (5). Assembles as shown.

Step 6

Item	Drawing	Qty
1		2
5		4
6		2

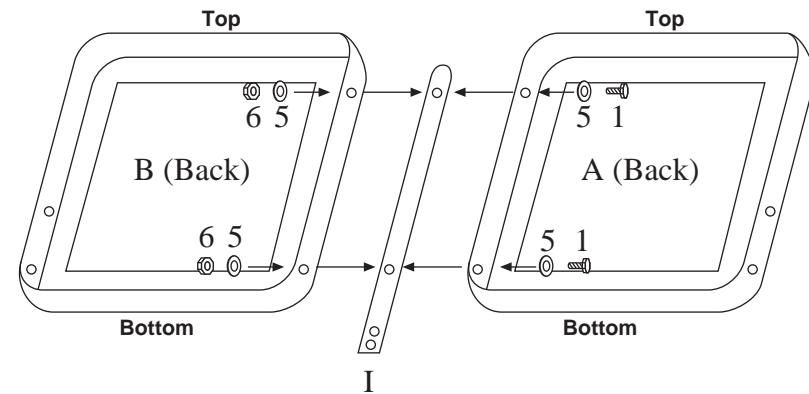

Place the flat metal bar (I) in one end and connect two back panels with bolt (1) and washer (5) and nut (6) on other side.

ATTENTION : DO NOT TIGHTEN ALL OF THE NUTS UNTIL THE FINAL STEP IS COMPLETED. IMPORTANT TO FULLY TIGHTEN BEFORE SITTING ON CHAIR.

Step 7

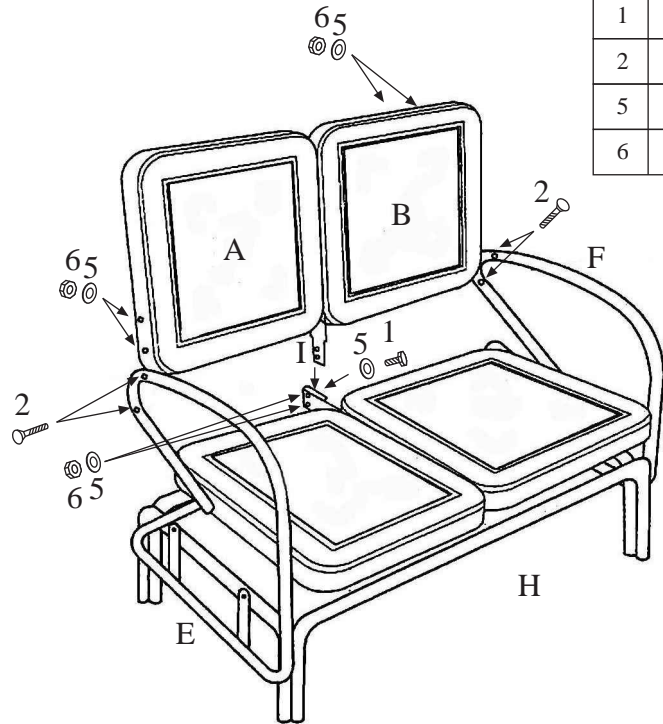

Item	Drawing	Qty
1		2
2		4
5		8
6		6

Plug the seat back's center bar (I) into the hole of center bar (H) on seat bottom. Tighten the bar with bolt (1) washer (5) and nut (6).

Then fix the seat back with arm side frames with bolt (2) the outside, washer (5) and nut (6) on the inside. Assemble as shown.

IMPORTANT:

Exposure to harsh weather conditions may encourage rusting of the steel metal components. Protection from these conditions is recommended.

Step 8

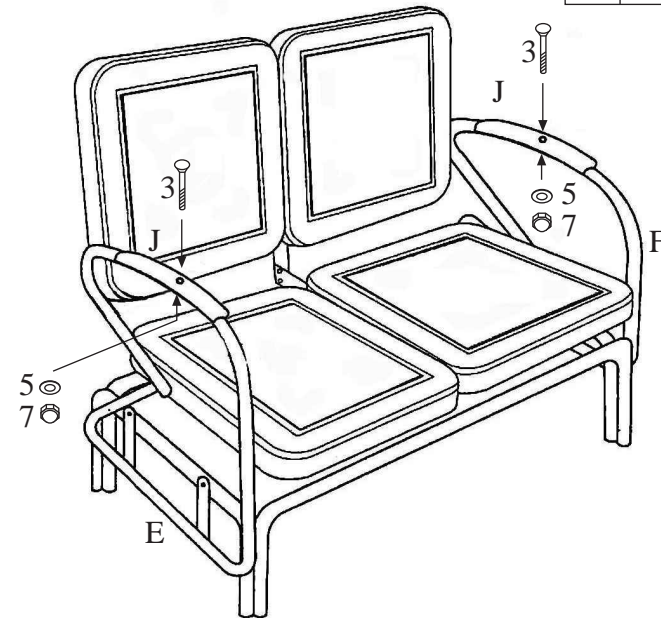

Item	Drawing	Qty
3		2
5		2
7		2

Carefully line up the holes in arm cover (J) with holes on arm frame (E/F), using a quick downward push, snap cover over frame. Attach arm holder to each side frame with the bolt (4). Then washer (5) and round top nut (7) should be used underneath the arm cover. Assemble as shown.