

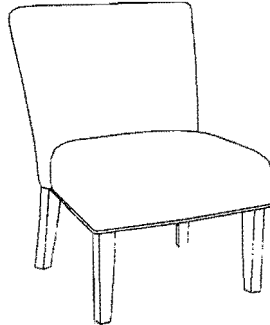

4D CONCEPT

Oversize Accent Chair

72850



NEED ASSISTANCE ?

Call 4 D CONCEPTS directly for parts or assemble assistance

Individual stores do not stock part

Call our Toll-free number Five days a week, except holidays :

Monday through Friday 8:00am to 5:00pm

West Coast Time

1 - 888 - 310 - 4326



Important : Before calling for assistance, please have the Model number, Part number, and Packing code ready for one of our Customer Service Representatives. You will find the model number and part number on the first pages of the instruction sheet. You will find the packing code . jet printed or stamped on the long side of the carton.

MODEL # : _____



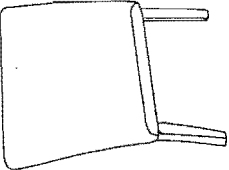

PACKING CODE # : _____

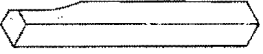
It's important that you retain the model number and the packing code along with the original receipt of purchase for future reference.

PARTS IDENTIFICATION

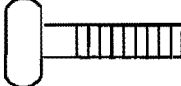
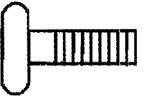
(1)		1PC
(2)		1PC
(3)		2PCS

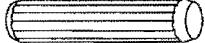
HARDWARE IDENTIFICATION

A		$\phi 5/16'' \times 100\text{mm}$	4PCS
B		$\phi 5/16'' \times 60\text{mm}$	6PCS
C		$\phi 8\text{mm}$	10PCS
D		$\phi 22\text{mm}$	10PCS
E			1PC
F		$\phi 5\text{mm}$	1PC

