

Assembly Instructions

RATTAN FUTON DRAWERS

Patent Pending US# 29/193,130

Note that the parts shown are Chair size.

1204

1 Assembled view

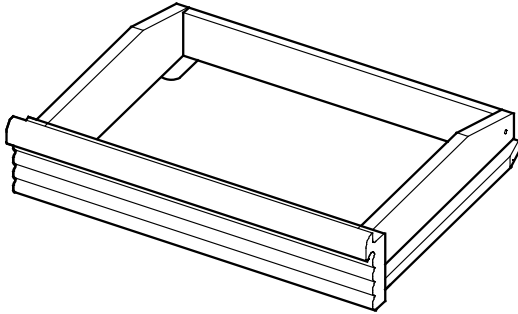

2 Parts in this box

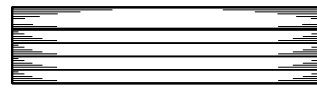

Drawer Front x 1



Drawer Bottom x 1

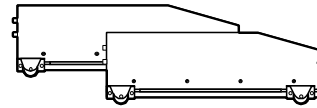

Side Panel x 2

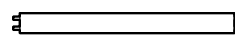

Support x 1



Back Panel x 1

3 Hardware in this box



60mm Bolts x 2



Barrel Nuts x 2

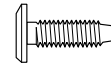

16mm Bolts x 4



Allen Key x 1

4 Slot Plywood Panel to the Side Panels.

Fit the Side Panel to the Drawer Front loosely. Slot in the Plywood Panel to the Side Panel and Drawer Front.

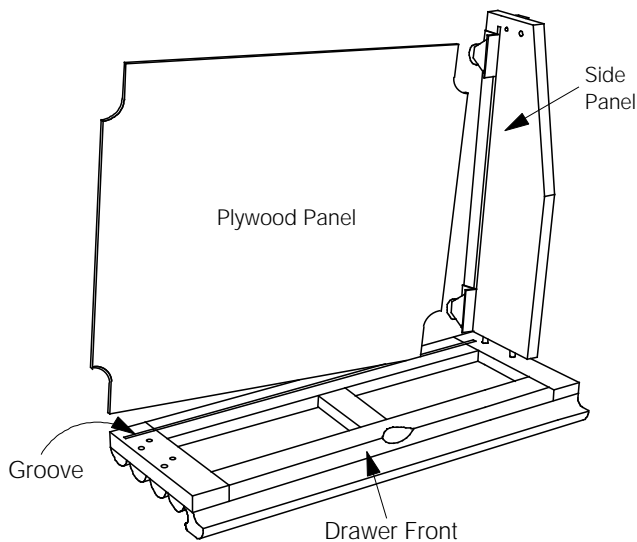

5 Fit Side Panel onto the Drawer Front.

Fit the Side Panels to the Drawer Front, fitting the Dowels in the holes. Use two 16mm Bolts to attach the Side Panels in place.

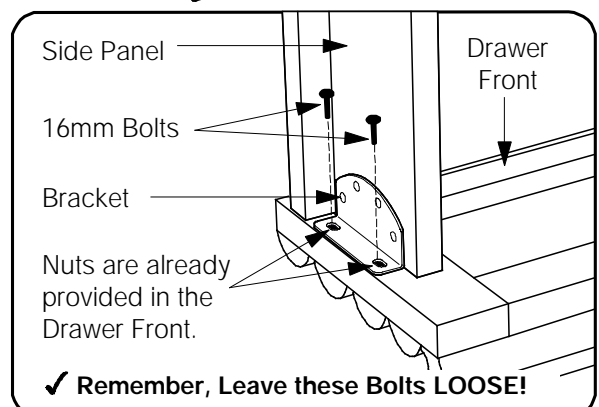
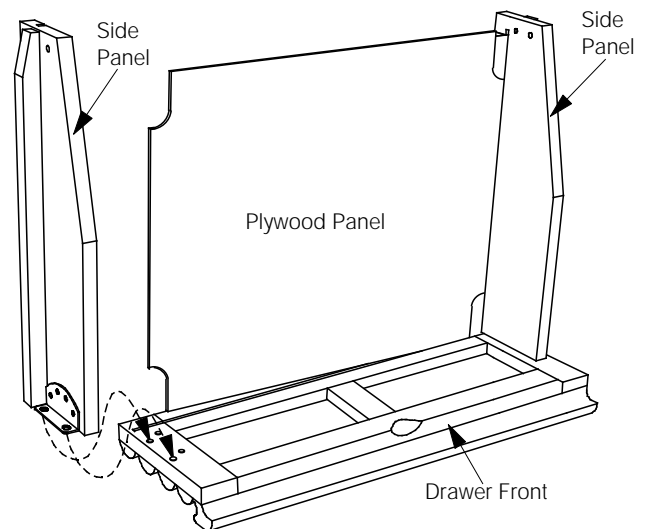

- ✓ Be sure the holes are free of wood chips and saw dust.
- ✓ Insert Barrel nuts as shown using a screwdriver. This will help you position the Nut in line with the Bolt.
- ✓ Do not force the Bolt as you may strip the thread. Be sure the thread is properly started.

Assembly Instructions

RATTAN FUTON DRAWERS

Patent Pending US# 29/193,130

Note that the parts shown are Chair size.

1204

6 Assembled view

Fit the Support into the dowel holes provided on the Drawer Front.

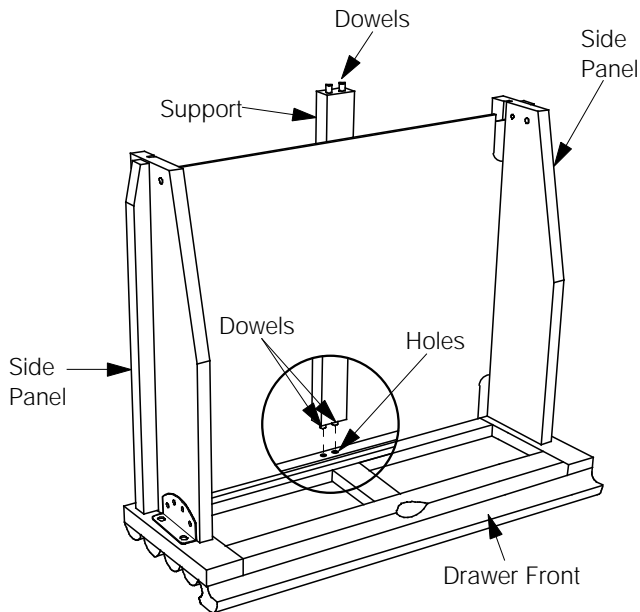

7 Fit Side Panel onto the Drawer Front.

You will need to spread the Side Panels apart a bit to fit the dowels in the Back Panel into their holes. Do this gently, please! After this tighten all the bolts on the Drawer Front.

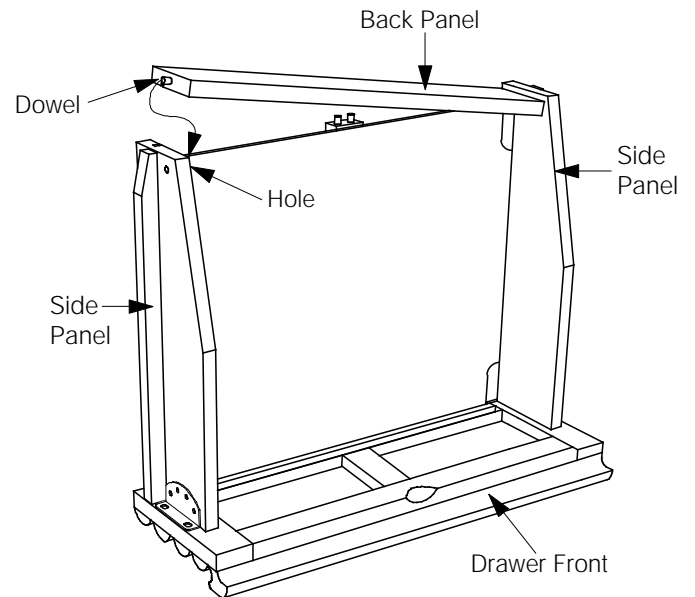

8 Bolt Back Panel in Place.

Carefully turn the assembled Drawer down, onto its wheels. Using the 60mm Bolts and Barrel Nuts, secure the Back Panel in place.

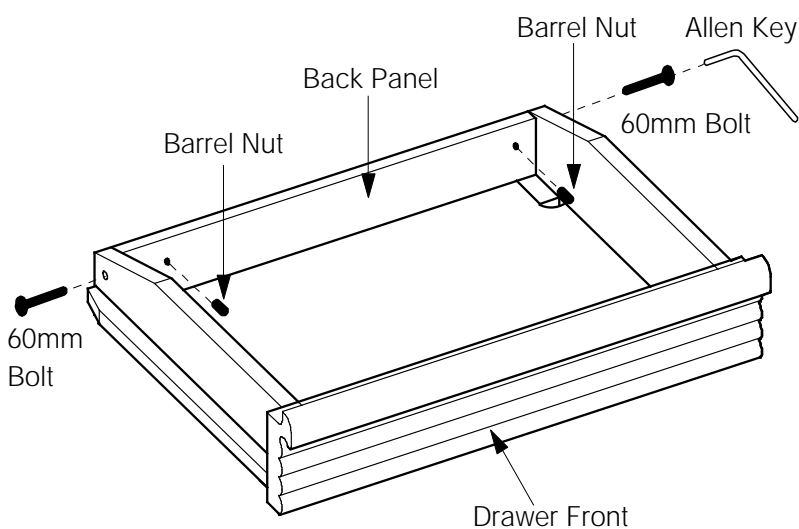

BOLT AND BARREL NUT ASSEMBLY SYSTEM

