

Assembly Instructions

1104

FUTON ACCESSORIES DRAWERS

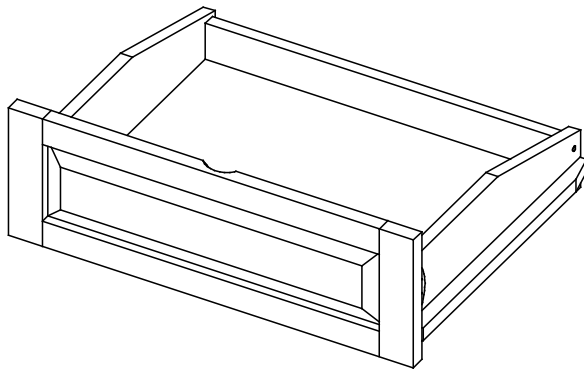

Step 1: Parts in this box

Note that the parts shown are for Chair size. For all other sizes, which have two drawers, there is double the quantity shown.

Step 2: Fit Side Panels to Drawer Face

Lay the Drawer Front on a smooth, flat surface so the holes and groove are facing upwards.

Fit the Side Panels to the Drawer Front, fitting the dowels in the holes. Use two 16mm Bolts to attach the Side Panel in place, but don't fully tighten these yet. Leave them a bit loose, to make fitting the Back Panel easier.

Fit the Support into dowel holes provided on the Drawer Front.

Instructions apply to drawers made for all sizes of futon:
Chair • Full/Double • Love seat • Queen

1 Parts in this box

PLEASE NOTE: Parts for Chair size as shown below, other sizes contain double the quantity below.

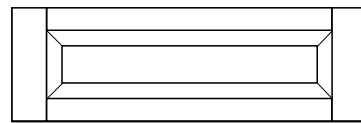

Drawer Front x 1 Piece

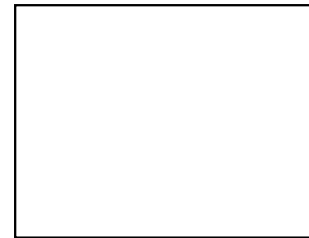

Drawer Bottom x 1 Piece

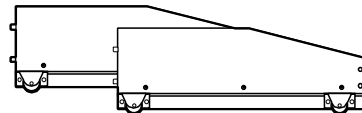

Side Panel x 2 Pieces

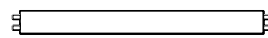

Support x 1 Piece

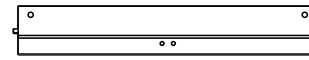

Back Panel x 1 Piece

Hardware Pack

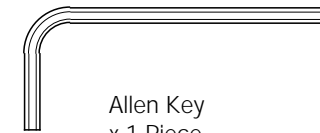

Allen Key
x 1 Piece

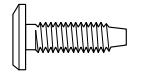

16mm Bolts
x 4 Pieces



60mm Bolts
x 2 Pieces



Barrel Nuts
x 2 Pieces

2 Fit Side Panels and Support onto Drawer Face.

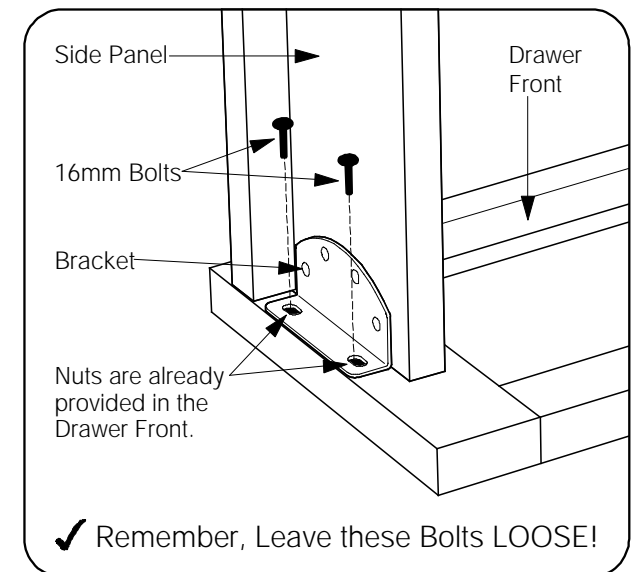
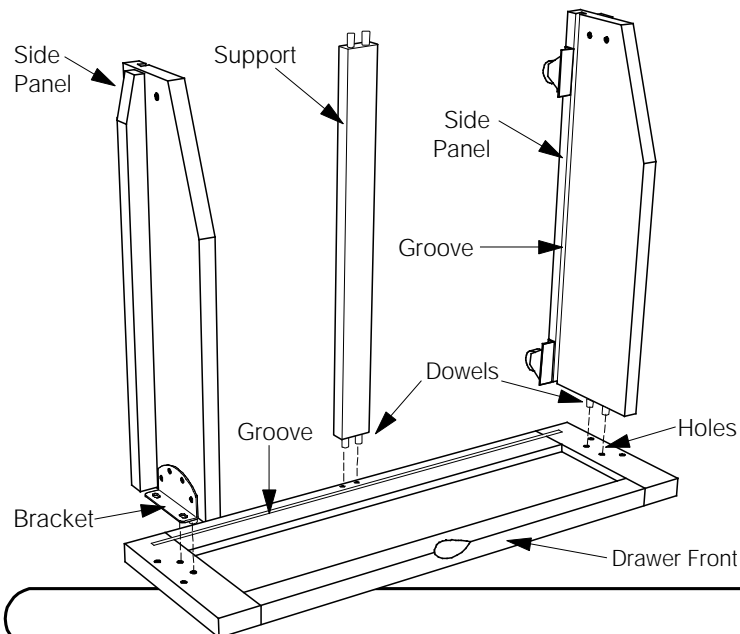

Assembly Instructions

1104

FUTON ACCESSORIES DRAWERS

Step 3: Fit Drawer Bottom

Guide the Drawer Bottom in carefully so that it won't jump out of its grooves. Be sure it fits fully into its groove at the bottom (in the Drawer Front,) before fitting the Back Panel.

Step 4: Fit Back Panel

You will need to spread the Side Panels apart a bit to fit the dowels in the Back Panel into their holes. Do this gently, please! Remember, the Bolts in Step 2 must be a bit loose. After this, tighten all the Bolts on the Drawer Front.

Step 5: Bolt Back Panel in place

Carefully turn the assembled Drawer down, onto its wheels. Using the 60mm Bolts and Barrel Nuts, secure the Back Panel in place.

- ✓ Be sure the holes are free of wood chips and saw dust.
- ✓ Insert Barrel nuts as shown using a screwdriver. This will help you position the Nut in line with the Bolt.
- ✓ Do not force the Bolt as you may strip the thread. Be sure the thread is properly started.

Instructions apply to drawers made for all sizes of futon:
Chair • Full/Double • Love seat • Queen

3 Fit Drawer Bottom

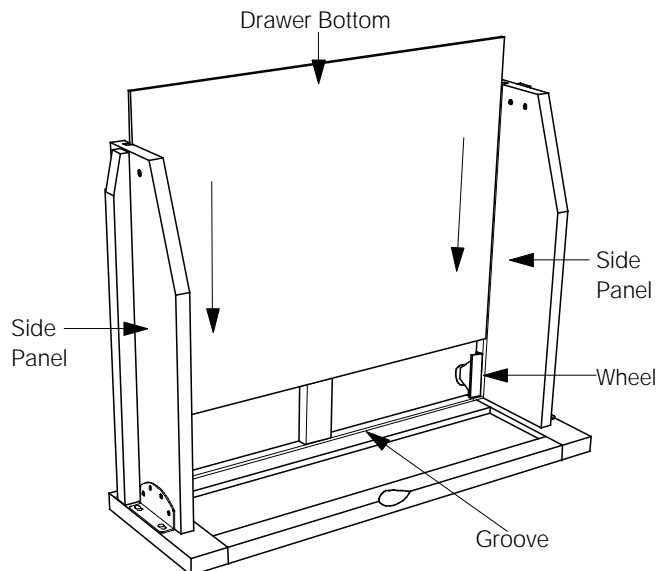

4 Fit Back Panel

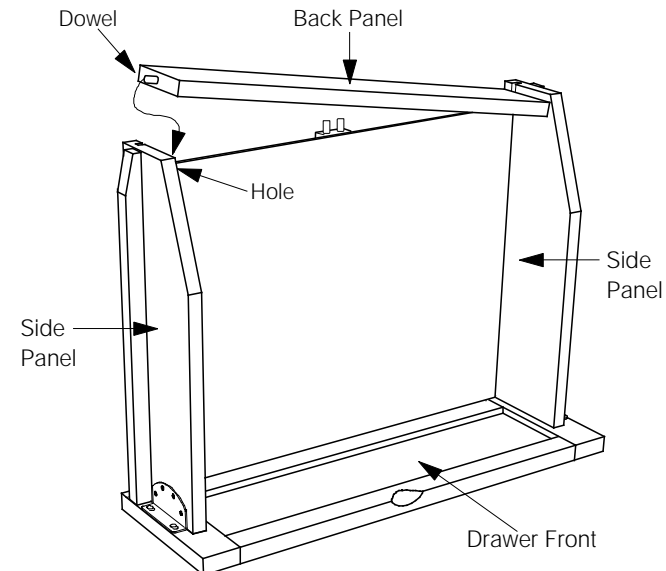

5 Bolt Back Panel in Place

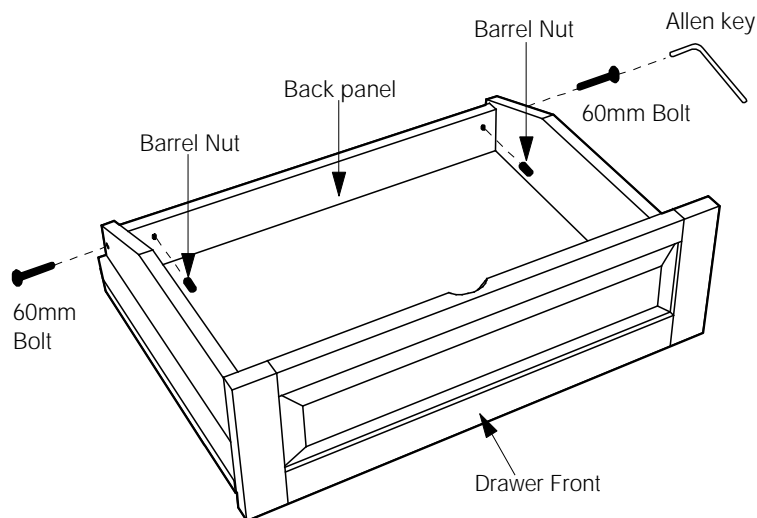

BOLT AND BARREL NUT ASSEMBLY SYSTEM

