

STAMINA
in STRIDE®
Pro®
Electronic Stepper
with Total Body Resistance Tubes

Owner's Manual

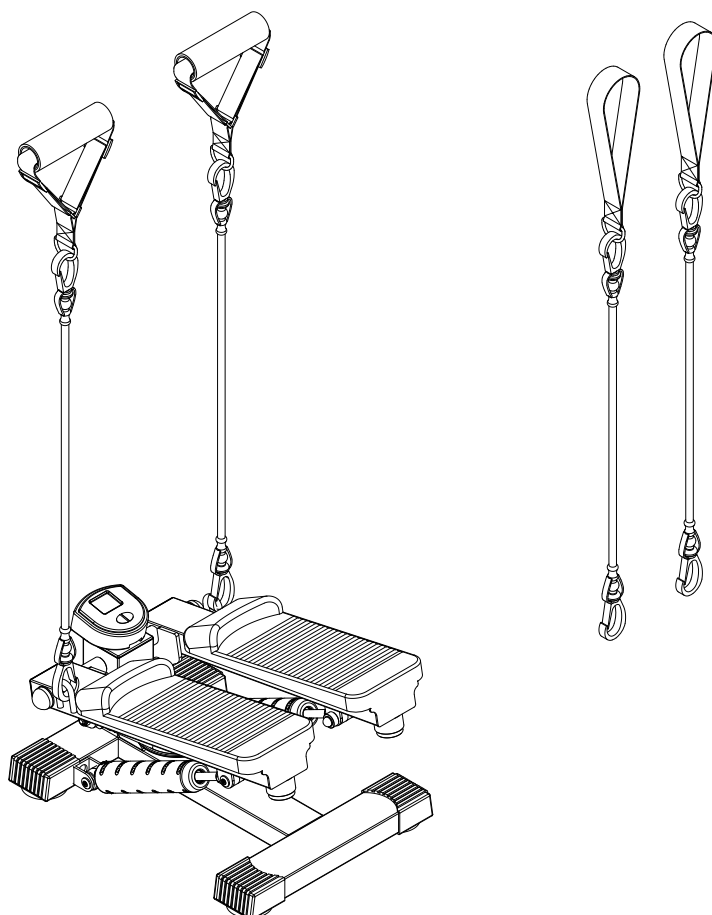

Product May Vary Slightly From Pictured.

CAUTION:
Weight on this product should not exceed 250 lbs.

⚠ WARNING

Exercise can present a health risk. Consult a physician before beginning any exercise program with this equipment. If you feel faint or dizzy, immediately discontinue use of this equipment. Serious bodily injury can occur if this equipment is not assembled and used correctly. Serious bodily injury can also occur if all instructions are not followed. Keep others and pets away from equipment when in use. Always make sure all bolts and nuts are securely tightened prior to each use. Follow all safety instructions in this manual.

When calling for parts or service, please specify the following number:

Model#: 40-0048A

This Product is Distributed Exclusively by



2040 N. Alliance, Springfield, MO 65803
Customer Service
1 (800) 375-7520
www.staminaproducts.com

STAMINA PRODUCTS
MADE IN TAIWAN

© 2012 Stamina Products, Inc.
2012, 01

TABLE OF CONTENTS

Safety Instructions	2	Operational Instructions	8
Before You Begin	4	Conditioning Guidelines	10
Equipment Warning, Caution & Notice Labels ...	5	Warm-Up and Cool-Down	11
Assembly Instructions	6	Product Parts Drawing	12
Set Up Instructions	7	Parts List	13
Storage	7	Warranty	14
Maintenance	7	Fax/Mail Ordering Form	15

SAFETY INSTRUCTIONS

⚠ WARNING This product contains a chemical known to the State of California to cause cancer and birth defects or other reproductive harm.

⚠ CAUTION Consult your physician before starting this or any exercise program. This is especially important if you are over the age of 35, have never exercised before, are pregnant, or suffer from any health problem. This product is for home use only. Do not use in institutional or commercial applications. Failure to follow all warnings and instructions could result in bodily injury and property damage.

⚠ WARNING To reduce the risk of serious injury, read the following Safety Instructions before using the InStride® Pro Electronic Stepper.

1. Read all warnings and cautions posted on the **InStride® Pro Electronic Stepper**.
2. The **InStride® Pro Electronic Stepper** should only be used after a thorough review of the Owner's Manual.
3. Keep children away from the **InStride® Pro Electronic Stepper**. Do not allow children to use or play on the **InStride® Pro Electronic Stepper**. Keep children and pets away from the **InStride® Pro Electronic Stepper** when it is in use.
4. Inspect the Resistance Tubes(28,29) for nicks and cuts before each use. Do not use Resistance Tubes(28,29) that are nicked or cut.
5. It is recommended that you place this exercise equipment on an equipment mat.
6. Set up and operate the **InStride® Pro Electronic Stepper** on a solid level surface. Do not position the **InStride® Pro Electronic Stepper** on loose rugs or uneven surfaces.
7. Make sure that adequate space is available for access to and around the **InStride® Pro Electronic Stepper**.
8. Shocks(6) on steppers get **HOT** during use. To avoid burns, do not touch the Shocks(6) until they have time to cool.
9. Always make sure that the Cable(9) is properly seated in the groove on the Pulley(8) before using the **InStride® Pro Electronic Stepper**.
10. Before using, inspect the **InStride® Pro Electronic Stepper** for worn or loose components, and securely tighten or replace any worn or loose components prior to use.
11. Consult a physician prior to commencing an exercise program. If, at any time during exercise, you feel faint, dizzy, or experience pain, stop and consult your physician.
12. Follow your physician's recommendations in developing your own personal fitness program.
13. Always choose the workout which best fits your physical strength and flexibility level. Know your limits and train within them. Always use common sense when exercising.
14. Do not wear loose or dangling clothing while using the **InStride® Pro Electronic Stepper**.
15. Never exercise in bare feet or socks; always wear correct footwear, such as running, walking, or crosstraining shoes. Be sure that they fit well, provide foot support and feature non-skid rubber soles.
16. Be careful to maintain your balance while using, mounting, dismounting, or assembling the **InStride® Pro Electronic Stepper**, loss of balance may result in a fall and bodily injury.
17. The **InStride® Pro Electronic Stepper** should not be used by persons weighing over 250 pounds.
18. The **InStride® Pro Electronic Stepper** should be used by only one person at a time.
19. The **InStride® Pro Electronic Stepper** is for consumer use only. It is not for use in public or semipublic facilities.

Call Us First



Customer Service
1 (800) 375-7520
www.staminaproducts.com

THANK YOU FOR PURCHASING THE InStride® Pro Electronic Stepper

To enact your warranty, please register your product
by going to register.staminaproducts.com

To help you get started, we have pre-assembled most of your
InStride® Pro Electronic Stepper at the factory with the exception
of those few parts left unassembled for shipping purposes.
Simply follow the few assembly instructions set forth in this manual.
With regular workouts, you will be getting your body into shape
and be on your way to achieving a happier and healthier lifestyle.

Should you have any questions,
please call our Customer Service Department toll-free number,
1 (800) 375-7520
Monday - Thursday, 7:30 A.M. - 5:00 P.M., Central Time.
Friday, 8:00 A.M. - 3:00 P.M., Central Time.



ONLINE
CUSTOMER SERVICE
customerservice@staminaproducts.com
www.staminaproducts.com



TELEPHONE
CUSTOMER SERVICE
Tel: 1 (800) 375-7520



FAX
CUSTOMER SERVICE
Fax: (417) 889-8064



MAIL
STAMINA PRODUCTS, INC.
ATTN: Customer Service
P.O. Box 1071
Springfield, MO. 65801-1071



BEFORE YOU BEGIN

Thank you for choosing the **InStride® Pro Electronic Stepper**. We take great pride in producing this quality product and hope it will provide many hours of quality exercise to make you feel better, look better, and enjoy life to its fullest.

It's a proven fact that a regular exercise program can improve your physical and mental health. Too often, our busy lifestyles limit our time and opportunity to exercise. The **InStride® Pro Electronic Stepper** provides a convenient and simple method to begin your assault on getting your body in shape and achieving a happier and healthier lifestyle.

Before reading further, please review the drawing below and familiarize yourself with the parts that are labeled.

Read this manual carefully before using the **InStride® Pro Electronic Stepper**.

Although Stamina constructs its products with the finest materials and uses the highest standards of manufacturing and quality control, there can sometimes be missing parts or incorrectly sized parts. If you have any questions or problems with the parts included with your **InStride® Pro Electronic Stepper**, please do not return the product. Contact us **FIRST!**

If a part is missing or defective, please go to staminaproducts.com to the Services section and order the part needed, or call us toll free at 1-800-375-7520 (in the U.S.). Our Customer Service Staff is available to assist you from 7:30 A.M. to 5:00 P.M. (Central Time) Monday through Thursday and 8:00 A.M. to 3:00 P.M. (Central Time) on Friday.

Be sure to have the name and model number of the product available when you contact us.

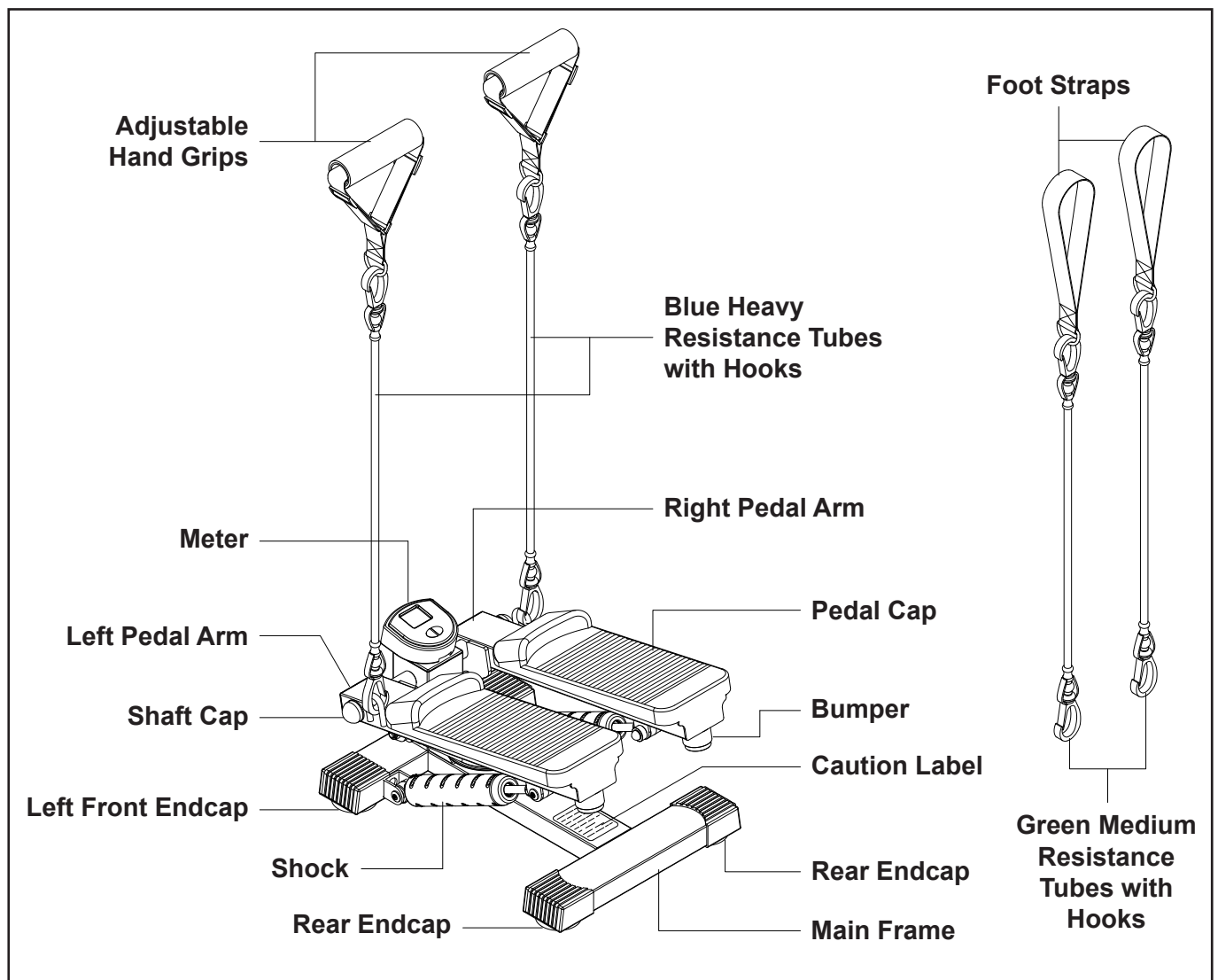

EQUIPMENT WARNING, CAUTION & NOTICE LABELS

This chart is provided to help identify the warning, caution, and notice labels on the **InStride® Pro Electronic Stepper**. Please take a moment to familiarize yourself with all of the warning, caution, and notice labels.

Labels are larger than actual size

C1 CAUTION LABEL(33)



C2 SHOCK DECAL(32)



(2 locations)

ASSEMBLY INSTRUCTIONS

Place all parts from the box in a cleared area and position them on the floor in front of you. Remove all packing materials from your area and place them back into the box. Do not dispose of the packing materials until assembly is completed. Read each step carefully before beginning. If you are missing a part, please go to staminaproducts.com under the Service section and order the part needed, e-mail us at customerservice@staminaproducts.com, or call us toll free at 1-800-375-7520 (in the U.S.). Our Customer Service Staff is available to assist you from 7:30 A.M. to 5:00 P.M. (Central Time) Monday through Thursday and 8:00 A.M. to 3:00 P.M. (Central Time) on Friday.

STEP 1

Lift up the **LEFT** and **RIGHT PEDAL ARMS(2, 3)**. Insert the **PULLEY BRACKET(7)** into the Collar on the **MAIN FRAME(1)**. Wrap the **CABLE(9)** around the **PULLEY(8)** and press the two **PEDAL ARMS(2, 3)** down. Refer to illustration **A**.

NOTE: Always make sure that the **CABLE(9)** is properly seated in the groove on the **PULLEY(8)** before using the **InStride® Pro Electronic Stepper**.

STEP 2

Refer to illustration **B**. Install one **AA** battery into the back of the **METER(13)**, the battery is not included. See page 9 for detailed battery installation instructions. Plug the **SENSOR WIRE(11)** into the **METER(13)**, then slide the **METER(13)** onto the **MOUNTING CAP(12)**.

NOTE: Please be careful not to damage the **SENSOR WIRE(11)** when attaching the **METER(13)** to the **MOUNTING CAP(12)**.

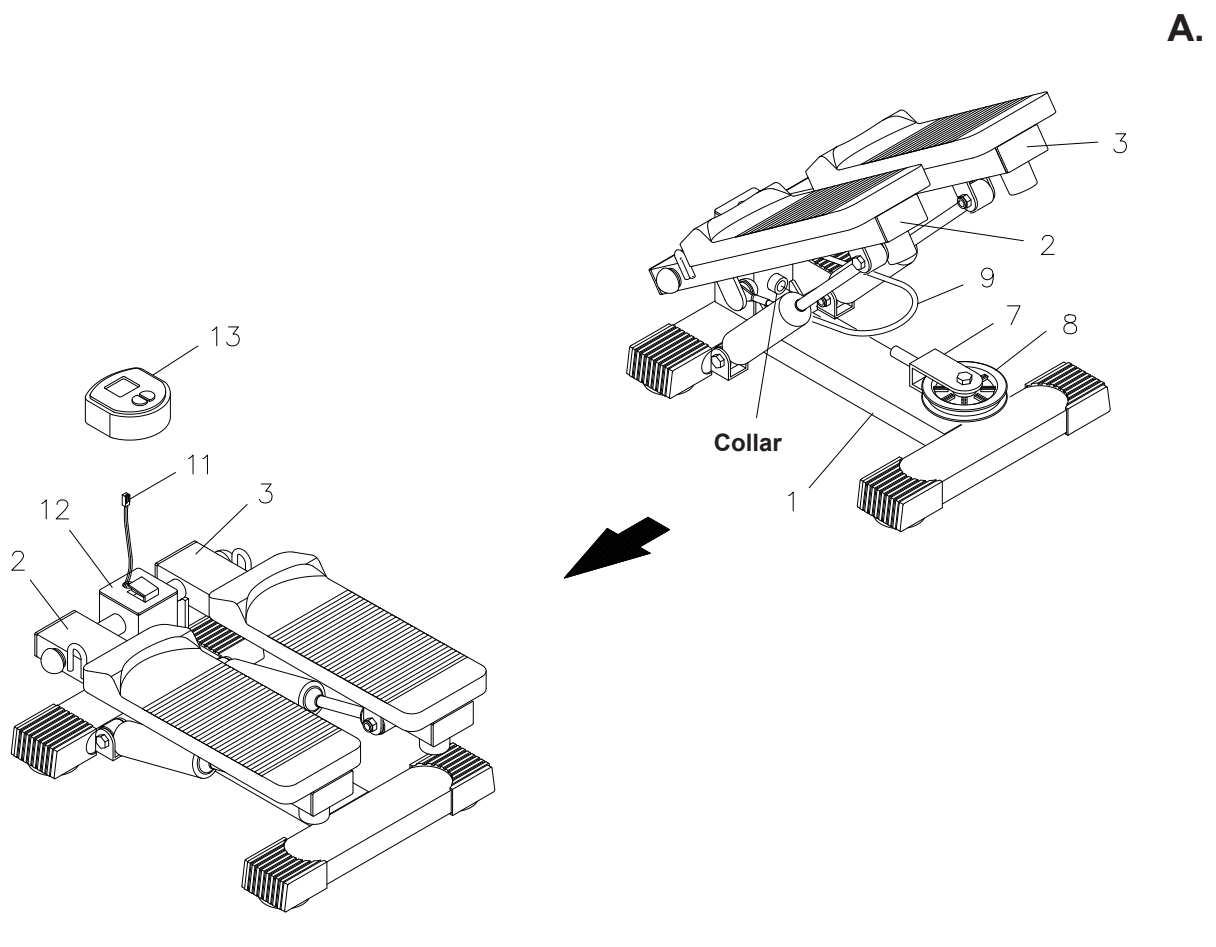

SET UP INSTRUCTIONS

Place the **InStride® Pro Electronic Stepper** in the area where it will be used. It is recommended that the **InStride® Pro Electronic Stepper** be placed on an equipment mat. The maximum operation dimensions of the **InStride® Pro Electronic Stepper** is approximately 16.4 inches long x 12.2 inches wide x 14.8 inches tall. (These dimensions may vary up to one inch.) Make sure that adequate space is available for access to passage around and emergency dismount from the **InStride® Pro Electronic Stepper**. A minimum of 20 inches on both sides and 20 inches either behind or in front of the **InStride® Pro Electronic Stepper** is required for safe operation.

LEVELING: Adjust the location of **InStride® Pro Electronic Stepper** so the stepper sits on the floor without rocking.

MOVING: The **InStride® Pro Electronic Stepper** must be lifted to be moved. Grasp the Front and Rear Stabilizers to move the **InStride® Pro Electronic Stepper**. Do not use the **PEDAL ARMS(2, 3)** to move the **InStride® Pro Electronic Stepper**. The **PEDAL ARMS(2, 3)** will move and the **SHOCK(6)** may pinch your hand or fingers.

FUNCTION INSPECTION:

NOTE: Always make sure that the **CABLE(9)** is properly seated in the groove on the **PULLEY(8)** before using the **InStride® Pro Electronic Stepper**.

Visually inspect the **InStride® Pro Electronic Stepper** to verify that assembly is as shown in the above illustration. Check the function of the **InStride® Pro Electronic Stepper**. Stand on the foot pedals and slowly move your highest foot downward and follow the natural path of the machine. The **SHOCKS(6)** should provide resistance for your workout.

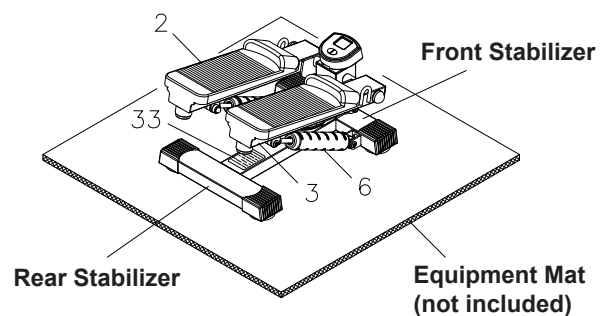

CAUTION: Locate and read the **CAUTION LABEL(33)** on the **InStride® Pro Electronic Stepper**. Make sure that all users read the **CAUTION LABEL(33)** before using the product.

STORAGE

1. To store the **InStride® Pro Electronic Stepper**, simply keep it in a clean dry place.
2. The minimum dimensions of **InStride® Pro Electronic Stepper** is approximately 16.4 inches long x 12.2 inches wide x 7.8 inches tall. These dimensions will vary. Please measure your **InStride® Pro Electronic Stepper** if exact dimensions are needed.
3. Grasp the Front and Rear Frame to move the **InStride® Pro Electronic Stepper**. Do not use the **PEDAL ARMS(2,3)** to move the **InStride® Pro Electronic Stepper**.
4. To avoid damage to the electronics, remove the battery before storing the **InStride® Pro Electronic Stepper** for one year or more.

MAINTENANCE

The safety and integrity designed into the **InStride® Pro Electronic Stepper** can only be maintained when the **InStride® Pro Electronic Stepper** is regularly examined for damage and wear. Special attention should be given to the following:

1. Inspect the **RESISTANCE TUBES(28, 29)** for nicks and cuts. Replace damaged **RESISTANCE TUBES(28, 29)**.
2. Verify that the **SHOCKS(6)** provide resistance by pushing down on the foot pedals.
3. **SHOCKS(6)** on steppers get **HOT** during use. To avoid burns, do not touch the **SHOCKS(6)** until they have time to cool.
4. Verify that the **CAUTION LABEL(33)** is in place and easy to read. Call Stamina Products immediately (1-800-375-7520) for a replacement Warning Label if the **CAUTION LABEL(33)** is missing or damaged.
5. It is the sole responsibility of the user/owner to ensure that regular maintenance is performed.
6. Worn or damaged components shall be replaced immediately or the **InStride® Pro Electronic Stepper** removed from service until repair is made.
7. Only Stamina Products supplied components shall be used to maintain/repair the **InStride® Pro Electronic Stepper**.
8. Keep your **InStride® Pro Electronic Stepper** clean by wiping it off with an absorbent cloth after use.

OPERATIONAL INSTRUCTIONS

USING THE RESISTANCE TUBES

The InStride® Pro Electronic Stepper includes two **GREEN MEDIUM RESISTANCE TUBES(28)**, two **BLUE HEAVY RESISTANCE TUBES(29)**, two **FOOT STRAPS(30)** and two **ADJUSTABLE HAND GRIPS(31)**. These resistance tubes add total body toning to your cardiovascular workout. The resistance tubes can be used as follows:

1. Use with the **ADJUSTABLE HAND GRIPS(31)** with either or both sets of resistance tubes during your stepper workout or while standing stationary on the **InStride® Pro Electronic Stepper**.
2. Use the set of **GREEN MEDIUM RESISTANCE TUBES(28)** alone, the set of **BLUE HEAVY RESISTANCE TUBES(29)** alone, or for maximum resistance use both sets together, one blue and one green on each side.
3. Clip one end of each tube to the Rings located on the outside of the **LEFT and RIGHT PEDAL ARMS(2,3)** and hook the **ADJUSTABLE HAND GRIPS(31)** to the other ends of the resistance tubes for your workout.
4. The resistance tubes are detachable so they can be used alone for total body strength training without the **InStride® Pro Electronic Stepper**. **NOTE:** Do not use foot straps while standing on **InStride® Pro Electronic Stepper**. Only use the foot straps with the resistance tubes for exercises done without the **InStride® Pro Electronic Stepper**.

NOTE:

1. Inspect the **RESISTANCE TUBES(28, 29)** for nicks and cuts before each use. Replace damaged resistance tubes.
2. The length of the **ADJUSTABLE HAND GRIP(31)** can be adjusted by moving the buckles to other position. Refer to the detail view in the illustration.

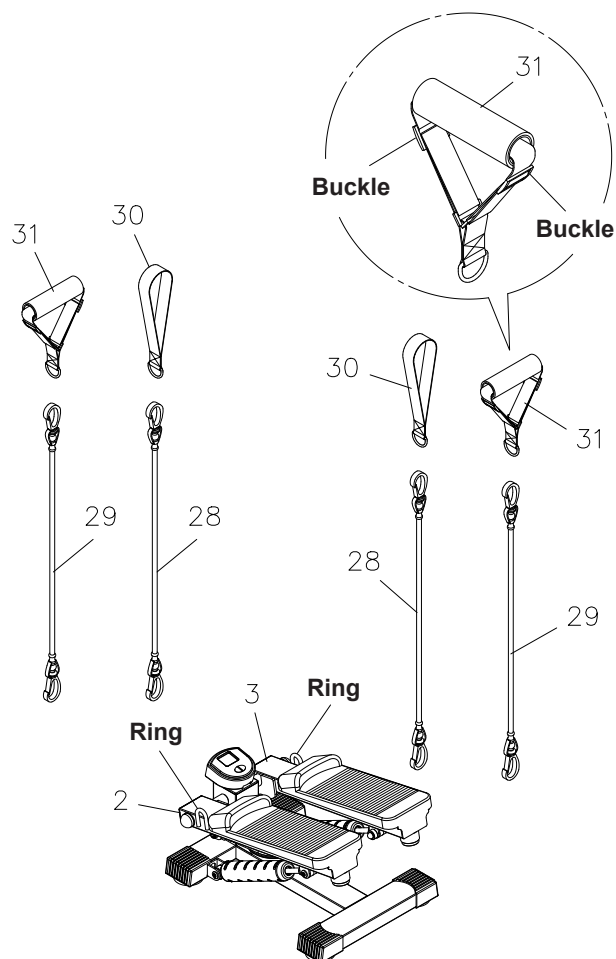

OPERATIONAL INSTRUCTIONS

USING THE FITNESS METER

POWER ON : Pedal movement or push any button.

POWER OFF : After four minutes of inactivity, the meter automatically shuts off. Function values are not saved.

FUNCTION BUTTONS:

MODE : Push to select the function of the lower readout.

RESET : To reset all functions to zero.

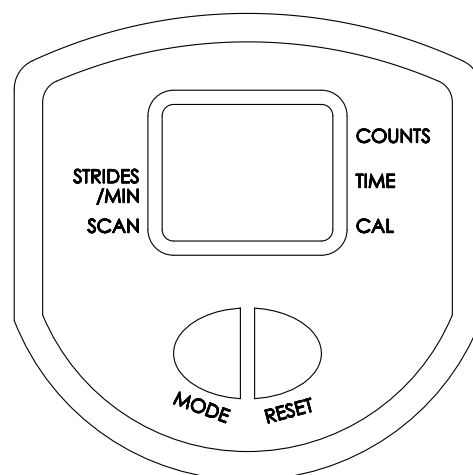

FUNCTIONS:

COUNTS : Upper readout displays the total number of strides you have taken from zero to 9999 strides.

SCAN: Automatically scans each function of **TIME**, **CALORIES**, **STRIDES/MIN** in sequence with change every six seconds.

TIME: Displays the stepping time from one second up to 59:59 minutes. After six seconds of inactivity, the meter will automatically stop timing the workout. Restart the workout time by moving the pedals.

STRIDES/MIN: Displays the rate of strides per minute.

CALORIES: Displays the calorie consumption from zero to 9999 cal.

The calorie readout is an estimate for an average user. It should be used only as a comparison between workouts on this unit.

HOW TO INSTALL AND REPLACE BATTERY:

1. Open the Battery Door on the back of the **METER(13)**.
2. The **METER(13)** operates with one AA battery, the battery is not included. Refer to the illustration to install or replace the battery.

NOTE: Rechargeable batteries are not recommended.

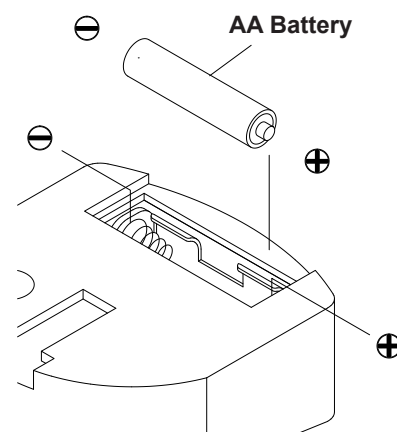

CONDITIONING GUIDELINES

How you begin your exercise program depends on your physical condition. If you have been inactive for several years or are severely overweight, start slowly and increase your workout time gradually. Increase your workout intensity gradually by monitoring your heart rate while you exercise.

Remember to follow these essentials:

- Have your doctor review your training and diet programs.
- Begin your training program slowly with realistic goals that have been set by you and your physician.
- Warm up before you exercise and cool down after you work out.
- Take your pulse periodically during your workout and strive to stay within a range of 60% (lower intensity) to 90% (higher intensity) of your maximum heart rate zone. Start at the lower intensity, and build up to higher intensity as you become more aerobically fit.
- If you feel dizzy or lightheaded you should slow down or stop exercising.

Initially you may only be able to exercise within your target zone for a few minutes; however, your aerobic capacity will improve over the next six to eight weeks. It is important to pace yourself while you exercise so you don't tire too quickly.

To determine if you are working out at the correct intensity, use a heart rate monitor or use the table below. For effective aerobic exercise, your heart rate should be maintained at a level between 60% and 90% of your maximum heart rate. If just starting an exercise program, work out at the low end of your target heart rate zone. As your aerobic capacity improves, gradually increase the intensity of your workout by increasing your heart rate.

Measure your heart rate periodically during your workout by stopping the exercise but continuing to move your legs or walk around. Place two or three fingers on your wrist and take a six second heartbeat count. Multiply the results by ten to find your heart rate. For example, if your six second heartbeat count is 14, your heart rate is 140 beats per minute. A six second count is used because your heart rate will drop rapidly when you stop exercising. Adjust the intensity of your exercise until your heart rate is at the proper level.

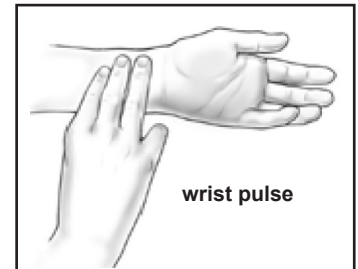

Target Heart Rate Zone Estimated by Age*

Age	Target Heart Rate Zone (55%-90% of Maximum Heart Rate)	Average Maximum Heart Rate 100%
20 years	110-180 beats per minute	200 beats per minute
25 years	107-175 beats per minute	195 beats per minute
30 years	105-171 beats per minute	190 beats per minute
35 years	102-166 beats per minute	185 beats per minute
40 years	99-162 beats per minute	180 beats per minute
45 years	97-157 beats per minute	175 beats per minute
50 years	94-153 beats per minute	170 beats per minute
55 years	91-148 beats per minute	165 beats per minute
60 years	88-144 beats per minute	160 beats per minute
65 years	85-139 beats per minute	155 beats per minute
70 years	83-135 beats per minute	150 beats per minute

* For cardiorespiratory training benefits, the American College of Sports Medicine recommends working out within a heart rate range of 55% to 90% of maximum heart rate. To predict the maximum heart rate, the following formula was used: $220 - \text{Age} = \text{predicted maximum heart rate}$

WARM-UP and COOL-DOWN

Warm-Up The purpose of warming up is to prepare your body for exercise and to minimize injuries. Warm up for two to five minutes before strength training or aerobic exercising. Perform activities that raise your heart rate and warm the working muscles. Activities may include brisk walking, jogging, jumping jacks, jump rope, and running in place

Stretching Stretching while your muscles are warm after a proper warm-up and again after your strength or aerobic training session is very important. Muscles stretch more easily at these times because of their elevated temperature, which greatly reduces the risk of injury. Stretches should be held for 15 to 30 seconds. Do not bounce.

Suggested Stretching Exercises

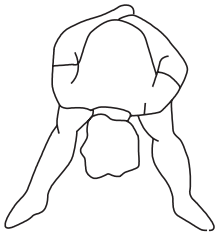

Lower Body Stretch

Place feet shoulder-width apart and lean forward. Keep this position for 30 seconds using the body as a natural weight to stretch the backs of the legs. **DO NOT BOUNCE!** When the pull on the back of the legs lessens, gradually try a lower position.

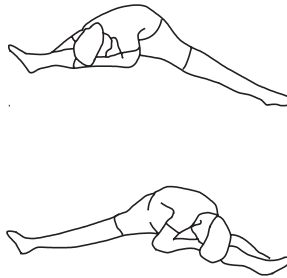

Floor Stretch

While sitting on the floor, open the legs as wide as possible. Stretch the upper body toward the knee on the right leg by using your arms to pull your chest to your thighs. Hold this stretch 10 to 30 seconds. **DO NOT BOUNCE!** Do this stretch 10 times. Repeat the stretch with the left leg.

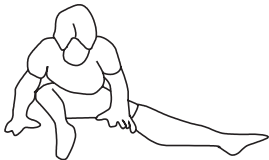

Bent Torso Pulls

While sitting on the floor, have legs apart, one leg straight and one knee bent. Pull the chest down to touch the thigh on the leg that is bent, and twist at the waist. Hold this position at least 10 seconds. Repeat 10 times on each side.

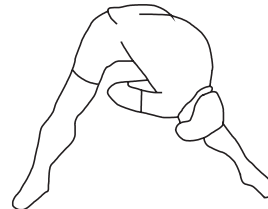
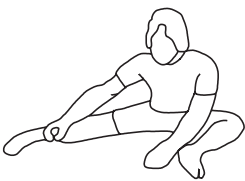

Bent Over Leg Stretch

Stand with feet shoulder-width apart and lean forward as illustrated. Using the arms, **gently** pull the upper body towards the right leg. Let the head hang down. **DO NOT BOUNCE!** Hold the position a minimum of 10 seconds. Repeat pulling the upper body to the left leg. Do this stretch several times slowly.

Remember to always check with your physician before starting any exercise program.

Cool-Down The purpose of cooling down is to return the body to its normal, or near normal, resting state at the end of each exercise session. A proper cool-down slowly lowers your heart rate and allows blood to return to the heart. Your cool-down should include the stretches listed above and should be completed after each strength training session.

PRODUCT PARTS DRAWING

FRONT

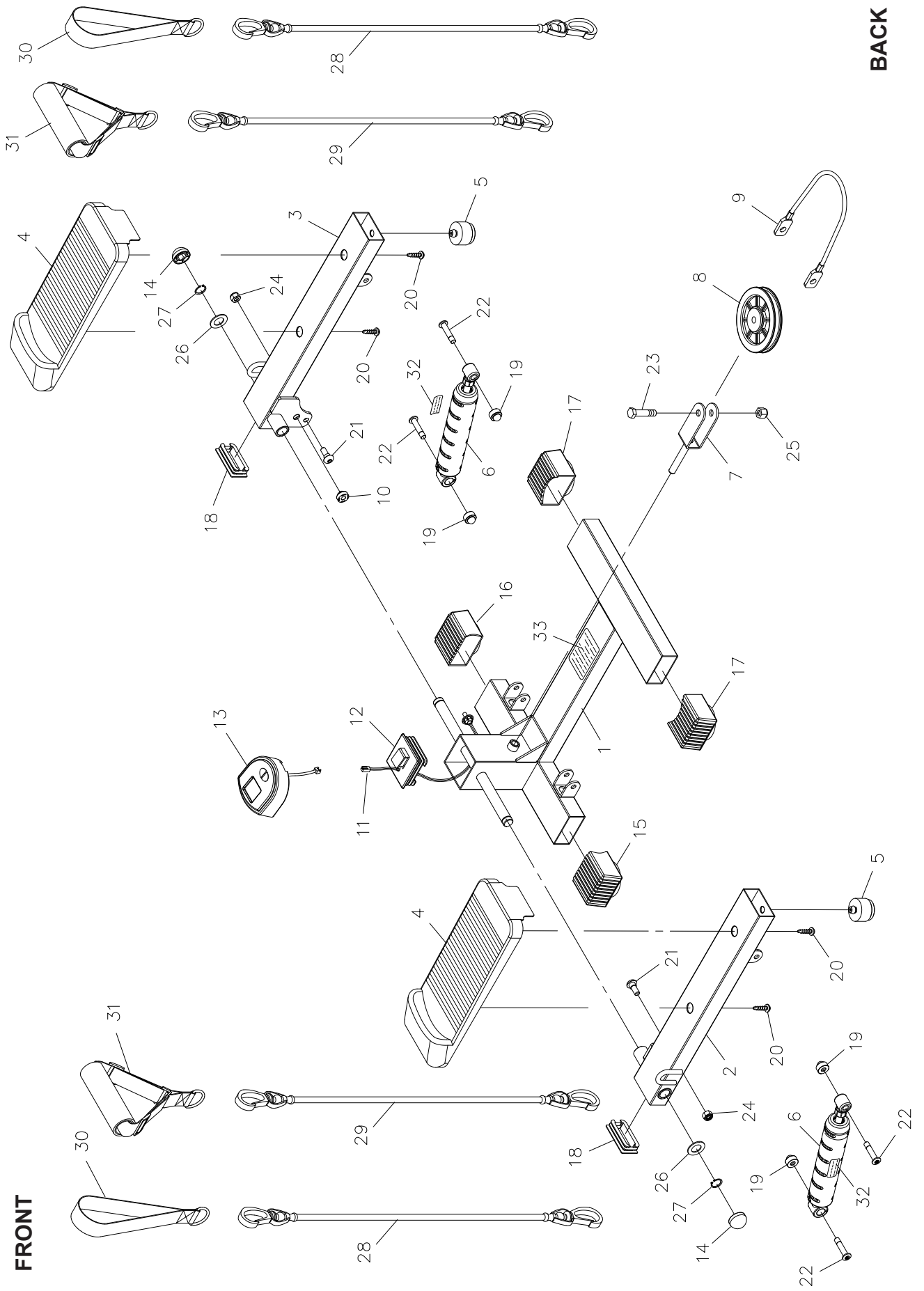

BACK

PARTS LIST

PART#	PART NAME	QTY
1	Main Frame	1
2	Left Pedal Arm	1
3	Right Pedal Arm	1
4	Pedal Cap	2
5	Bumper	2
6	Shock	2
7	Pulley Bracket	1
8	Pulley	1
9	Cable	1
10	Magnet	1
11	Sensor Wire	1
12	Mounting Cap (60 x 60mm)	1
13	Meter	1
14	Shaft Cap	2
15	Left Front Endcap (30 x 60mm)	1
16	Right Front Endcap (30 x 60mm)	1
17	Rear Endcap (30 x 60mm)	2
18	Rectangular Plug (30 x 60mm)	2
19	Fast Cap Nut (M8)	4
20	Bolt, Round Head (M6 x 25mm)	4
21	Shoulder Bolt, Button Head (M8 x 1.25 x 20mm)	2
22	Bolt, Button Head (M8 x 1.25 x 37mm)	4
23	Bolt, Hex Head (M10 x 1.5 x 38.5mm)	1
24	Nylock Nut (M8 x 1.25)	2
25	Nylock Nut (M10 x 1.5)	1
26	Washer (M16)	2
27	C Ring (16mm)	2
28	Green Medium Resistance Tube with Hooks	2
29	Blue Heavy Resistance Tube with Hooks	2
30	Foot Strap	2
31	Adjustable Hand Grip	2
32	Shock Decal	2
33	Caution Label	1
34	Manual	1
35	Workout Video (DVD)	1

LIMITED WARRANTY

MODEL 40-0048A

WARRANTY

Stamina Products, Inc. warrants that this product will be free from defects in materials and workmanship under normal use, service and proper operation for a period of 90 days on the parts and one year on the frame from the date of the original purchase from an authorized retailer. **THIS WARRANTY SHALL NOT APPLY TO ANY PRODUCT WHICH HAS BEEN SUBJECT TO COMMERCIAL USE, ABUSE, MISUSE, ALTERATION OF ANY TYPE OR CAUSE OR TO ANY DEFECT OR DAMAGE CAUSED BY REPAIR, REPLACEMENT, SUBSTITUTION OR USE WITH PARTS OTHER THAN PARTS PROVIDED BY STAMINA PRODUCTS, INC.** Commercial use includes use of the product in athletic clubs, health clubs, spas, gymnasiums, exercise facilities, and other public or semipublic facilities whether or not the product's use is in furtherance of a profit making enterprise, and all other use which is not for personal, family, or household purposes.

To implement this limited warranty, send a written notice stating your name, date, and place of purchase and a brief description of the defect along with your receipt to **Stamina Products, Inc. P.O. Box 1071, Springfield Missouri, USA, 65801-1071**, or email us at **customerservice@staminaproducts.com**, or call us at **1-800-375-7520**. If the defect is covered under this limited warranty, you will be requested to return the product or part to us for free repair or replacement at our option. **NO ACTION FOR BREACH OF THIS LIMITED WARRANTY MAY BE COMMENCED MORE THAN ONE (1) YEAR AFTER THE DATE THE ALLEGED BREACH WAS OR SHOULD HAVE BEEN DISCOVERED. NO ACTION FOR BREACH OF ANY IMPLIED WARRANTY MAY BE COMMENCED MORE THAN ONE (1) YEAR AFTER DELIVERY OF THE PRODUCT TO THE PURCHASER.** This limited warranty is not transferable. **IF ANY PART OF THE PRODUCT IS NOT IN COMPLIANCE WITH THIS LIMITED WARRANTY OR ANY IMPLIED WARRANTY, THE REMEDY OF REPAIR OR REPLACEMENT IS THE EXCLUSIVE REMEDY AVAILABLE TO YOU.** In the event that the purchaser makes any claim under this limited warranty or any implied warranty, the Warrantor reserves the right to require the product to be returned for inspection, at the purchaser's expense, to the Warrantor's premises in Springfield, Missouri. Return of the enclosed warranty registration card is not required for warranty coverage, but is merely a way of establishing the date and place of purchase.

Stamina Products, Inc. **SHALL NOT BE LIABLE FOR THE LOSS OF USE OF ANY PRODUCT, LOSS OF TIME, INCONVENIENCE, COMMERCIAL LOSS OR ANY OTHER INDIRECT, CONSEQUENTIAL, SPECIAL OR INCIDENTAL DAMAGES DUE TO BREACH OF THE ABOVE WARRANTY OR ANY IMPLIED WARRANTY.**

This limited warranty is the only written or express warranty given by Stamina Products, Inc. This warranty gives you specific legal rights, and you may also have other legal rights which vary from state to state. **ANY OTHER RIGHT WHICH YOU MAY HAVE, INCLUDING ANY IMPLIED WARRANTY OR MERCHANTABILITY OR FITNESS FOR A PARTICULAR PURPOSE, IS LIMITED IN DURATION TO THE DURATION OF THIS WARRANTY.**

The laws in some jurisdictions restrict the rights of manufacturers and distributors of consumer goods to disclaim or limit implied warranties and consequential and incidental damages with respect thereto. If any such law is found to be applicable, the foregoing disclaimers and limitations of and on implied warranties and consequential and incidental damages with respect thereto shall be disregarded and shall be deemed not to have been made to the extent necessary to comply with such legal restriction.

TO CONTACT CUSTOMER SERVICE

For your convenience, Stamina's customer service representatives can be reached by email at customerservice@staminaproducts.com or by phone at 1-800-375-7520 (in the U.S.). Our customer service representatives are available Monday through Thursday from 7:30 a.m. until 5:00 p.m., and Friday 8:00 a.m. until 3 p.m. Central Time.



**ONLINE
CUSTOMER SERVICE**
customerservice@staminaproducts.com
www.staminaproducts.com



**TELEPHONE
CUSTOMER SERVICE**
Tel: 1 (800) 375-7520



**FAX
CUSTOMER SERVICE**
Fax: (417) 889-8064



**MAIL
STAMINA PRODUCTS, INC.**
ATTN: Customer Service
P.O. Box 1071 Springfield, MO. 65801-1071

Would you like to receive email information or special offers from Stamina Products? Register at contact.staminaproducts.com

TO REGISTER YOUR PRODUCT

To enact your warranty, please register your product by going to register.staminaproducts.com. Please have your product model number (printed on the cover of this owner's manual) and the serial number (printed on the black and white sticker on your product) ready.

If you don't have internet access, you can call customer service at 1-800-375-7520, or fill out and mail the product registration form below to Stamina Products, Inc.; P.O. Box 1071; Springfield, MO 65801-1071.

PRODUCT REGISTRATION FORM	Stamina Products, Inc. P.O. Box 1071 Springfield, MO 65801-1071
Model Number:	Serial Number:
Product Name:	
Place Purchased:	
Date of Purchase:	Purchase Price:
First Name:	Last Name:
City:	State: Zip Code:
Email Address:	Phone #: ()
Would you like to receive email information or special offers from Stamina Products?* <input type="checkbox"/> Yes <input type="checkbox"/> No *If yes, be sure your email address is included above.	



Detach and Mail or Fax the Form Above



TO ORDER PARTS

If there are missing or damaged parts, you can go to parts.staminaproducts.com and order those parts. If you have questions, please contact customer service. Do not return the product. To order parts by mail, fill out the sheet below and fax it to 417-889-8064. The part will be mailed to your address.

PARTS ORDER FORM	Stamina Products, Inc. P.O. Box 1071 Springfield, MO 65801-1071	
Mr./Ms:		
Address: Apt. #:		
City: State: Zip Code:		
IMPORTANT : We must have your phone number to process the order!		
Phone #: () Work Phone #: ()		
Date of Purchase:		
Model #:		
Purchased From:		
IMPORTANT : Before filling out the form below make sure you have the correct information. Refer to the parts list to make sure you're ordering the right parts!		
PART #	DESCRIPTION	QUANTITY
EXAMPLE: 1	Rear Unit Assembly	1



Detach and Mail or Fax the Form Below

