

THE STAND

Owner's Manual

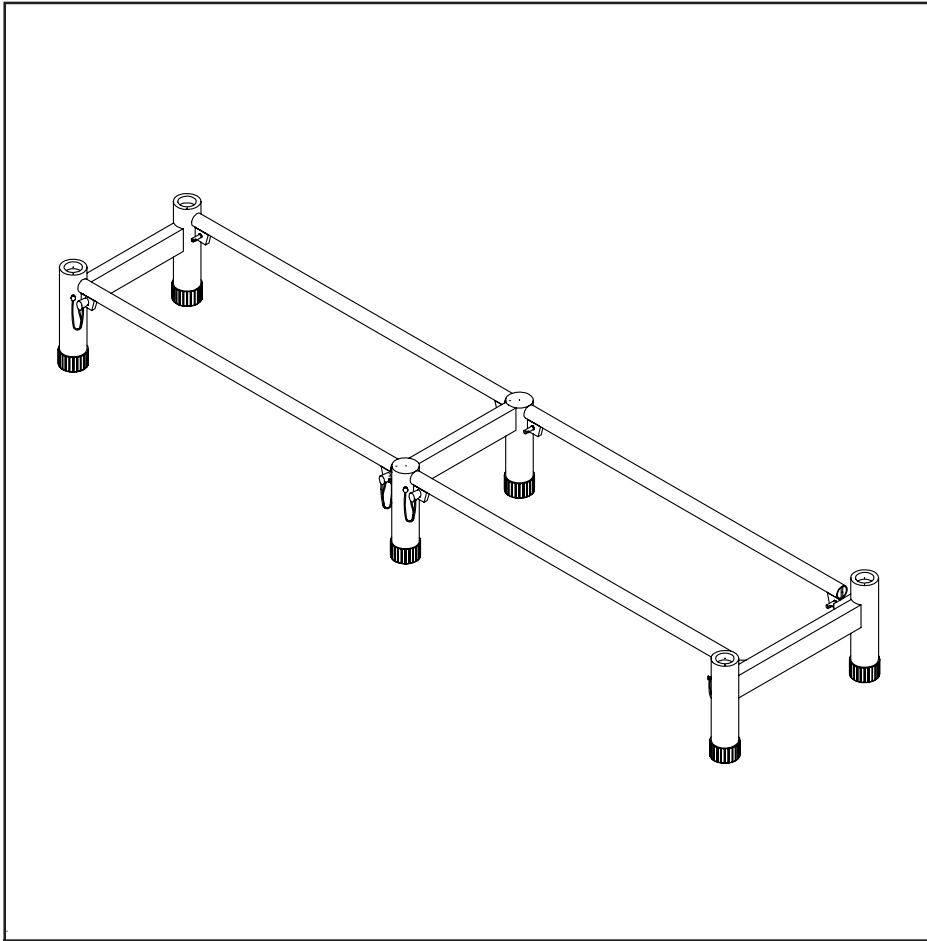

**Assembly
Instructions**

Warranty

Color	Model Number
Tan	55-4100
Black	55-4150

**Model Number
55-4100 / 4150**

**STAMINA PRODUCTS
MADE IN CHINA**

This Product is Produced Exclusively by

***Stamina*[®]
PRODUCTS, INC.**

2757 S. Austin, Springfield, MO 65807

Customer Service Number

1 (800) 375-7520

ASSEMBLY INSTRUCTIONS

Place all parts from the box in a cleared area and position them on the floor in front of you. Remove all packing materials from your area and place them back into the box. Do not dispose of the packing materials until assembly is completed. Read each step carefully before beginning. If you are missing a part please call our toll-free number for assistance **1 (800) 375-7520**.

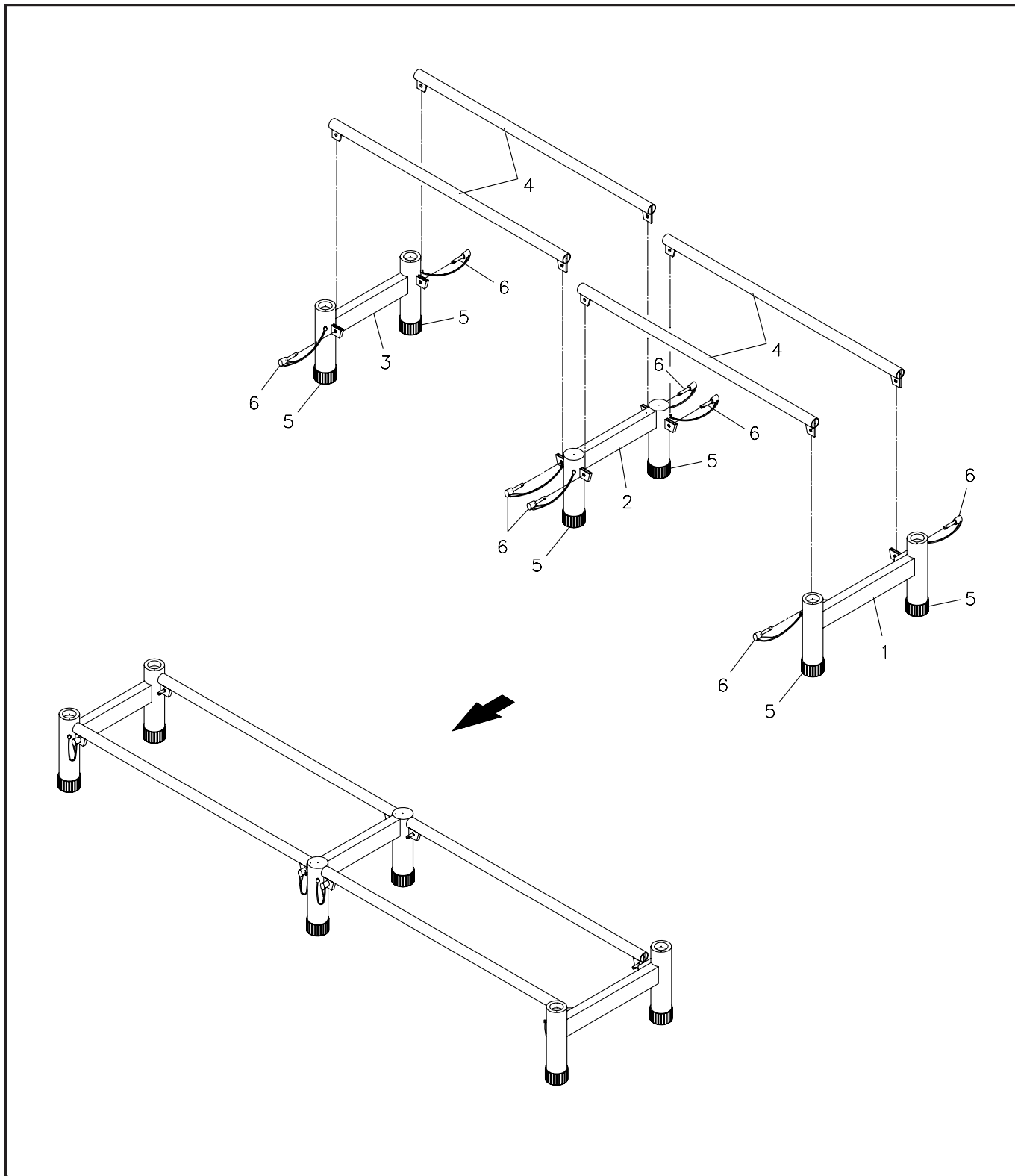

PARTS LIST

DIAGRAM#	PART NAME	QTY
1	Front Stand	1
2	Middle Stand	1
3	Rear Stand	1
4	Connection Bar	4
5	Endcap	6
6	Pull Pin	8
7	Manual	1

ASSEMBLY INSTRUCTIONS

Connect the **FRONT STAND(1)** to the **MIDDLE STAND(2)** with two **CONNECTION BARS(4)** and lock in the place with the **PULL PINS(6)**. Repeat to connect the **REAR STAND(3)** to the **MIDDLE STAND(2)**.

THE STAND is designed to elevate the **PILATES PREMIER** and the *Pilates Performer* machine. Place your PILATES machine onto the stand as shown in the illustration.

NOTE: The feet of the Pilates machines must fit into the **FRONT STAND(1)** and the **REAR STAND(3)**. The **FRONT STAND(1)** is wider than the **REAR STAND(3)**. The Foot Rest end of your Pilates machine will fit into the top of the **FRONT STAND(1)** and the Headrest end of your Pilates machine will fit into the **REAR STAND(3)**.

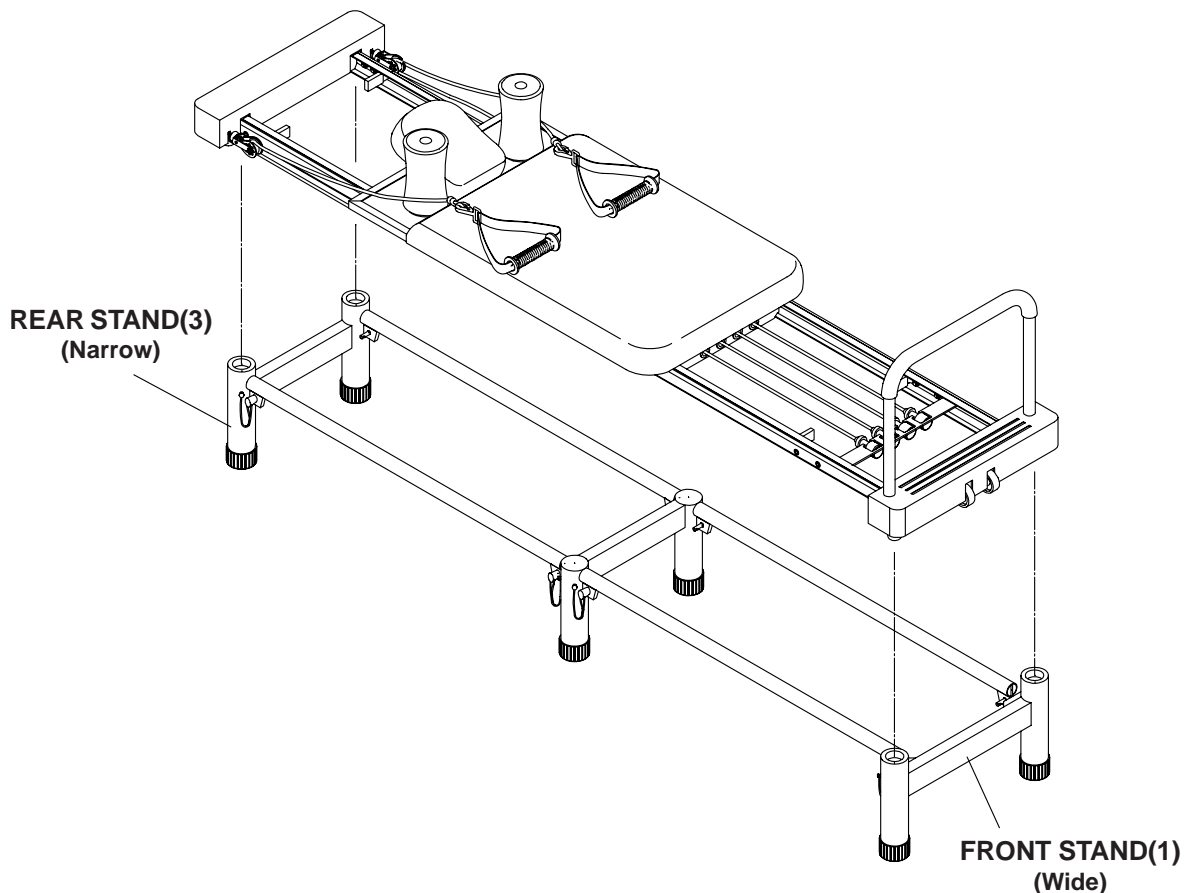

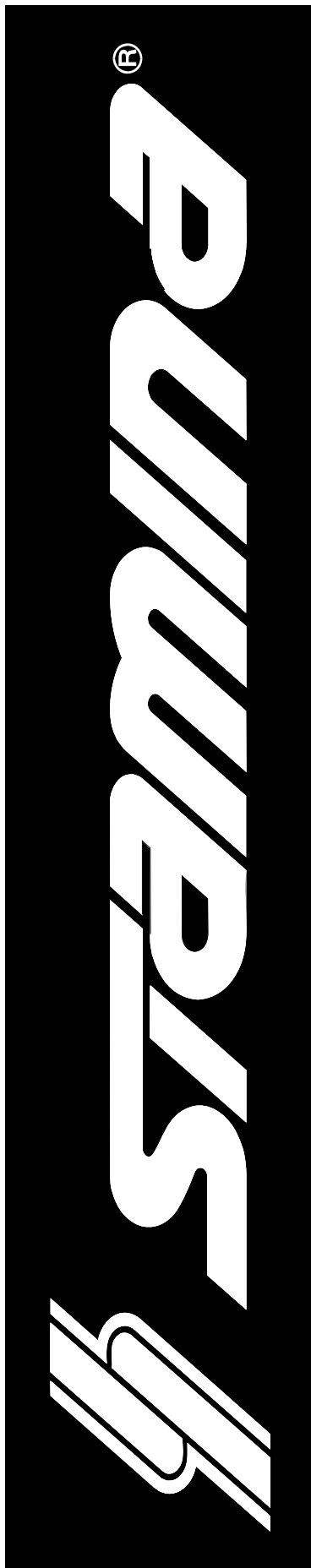

**CALL
US FIRST
1 (800) 375-7520**

THANK YOU FOR PURCHASING *The Stand*

Simply follow the few assembly instructions set forth in this manual. Within a few minutes you will be getting your body into shape and on your way to achieving a happier and healthier lifestyle.

Although Stamina tries to manufacture its products with the finest materials and uses the highest standards of manufacturing, occasionally a part that does not fit, is the incorrect size, or is otherwise inappropriate is found. Even with the highest inspection and quality controls in place these things will happen occasionally. Please do not return the product. For your convenience, Stamina has a Customer Service Department with a toll-free number. If a part is missing, does not fit, is the incorrect size, or is otherwise inappropriate, please call 1 (800) 375-7520 (in the U.S.) between 8:00 A.M. and 5:00 P.M. Central Time, Monday through Friday. Our operators will be able to assist you with your problem and the parts will be mailed directly to your house.

MANUFACTURER'S LIMITED WARRANTY

This product is warranted to be free of defects in material and workmanship and to be in perfect working order at the time of purchase.

If the product should, for any reason, become defective within 90 days of purchase, the manufacturer will replace the product once it is returned to the manufacturer. This warranty does not apply to any damage caused by accident, return transit, alteration, abuse, or misuse. There are no other warranties other than those expressly set forth herein.

Products shipped to the manufacturer must be in the original shipping carton with freight prepaid.

All expenses for repairing or replacing the product, including the cost of shipping it back to the original purchaser, will be covered by the manufacturer. This warranty gives you specific legal rights, and you may have other rights which vary from state to state.

