

S1/S2 Sport Series

LifeSpan™

Indoor Bike

Owner's Manual

LifeSpan™

by PCE
HEALTH & FITNESS

Welcome to LifeSpan

We all know that exercise is a key component to achieving the level of Health and Fitness that all of us desire. Whether or not our motivation is Weight Loss, Active Living, Sports Training or to manage a Chronic Disease like high blood pressure, exercise is a core element to accomplishing our goals and maintaining a long and healthy life.

At LifeSpan, we design and manufacture our equipment to meet the needs of our varied customers and what motivates them to exercise. LifeSpan Sport product models are specifically designed for people interested in Sports Training and Active Living. Special attention is given to ergonomics, and replicating the actual outdoor activity – indoors. In addition, we know that our Sports model customers are serious about exercise. As a result, we design all LifeSpan Sport product models to be durable and last through years of use.

To learn more about exercise for Sports Training, Healthy Living, Weight Management or Disease Management visit our web site at www.LifeSpanfitness.com

Before assembly and operation of your S1/S2 Indoor Bike please read this Owners Manual in its entirety. Remember that some service should only be performed by a qualified service technician. If service is required, please contact your authorized LifeSpan retailer or log onto the LifeSpan Fitness web site and click on customer support. Use the following information to contact us directly:

PCE Health and Fitness
PO Box 981316
Park City, Utah 84098-1316
Phone: (801) 973.9993 ext. 4
Fax: (801) 973.9923
Web site: www.LifeSpanFitness.com

Neither PCE Health and Fitness nor its representatives can accept responsibility for any damage or injury incurred as a result of information presented in the manual except under the terms of the product warranty.

Table of Contents

Welcome to Lifespan	3
Specifications	5
Limited Home Use Warranty	6
Important Safety Precautions	7
S1 Contents	8
S1 Assembly Instructions	9
S1 Assembly Instructions Continued	10
S2 Contents	11
S2 Assembly Instructions	12
S2 Assembly Instructions Continued	13
S1/S2 Adjustments	14
S1 Exploded View	15
S2 Exploded View	16
Extended Warranty	19
Serial Number Information	20

Specifications

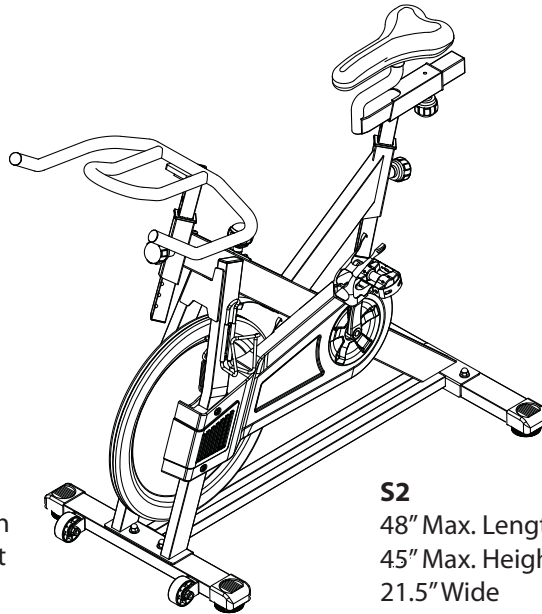

	S1	S2
Dimensions:	48" Max. Length 47" Max. Height 18" Wide	48" Max. Length 45" Max. Height 21.5" Wide
Product Weight:	84 lbs.	97 lbs.
Flywheel:	31 lbs.	40 lbs.
Adjustments:	Seat Height Handlebar Height Seat Fore/Aft	Seat Height Handlebar Height Seat Fore/Aft
Pedals:	Alloy with sealed bearings	Alloy with sealed bearings
Handlebars:	PVC Dipped	PVC Dipped
Tension Control:	Micro Adjustment knob with felt pad friction control	Micro Adjustment knob with felt pad friction control
Seat:	Standard Mount Seat	Standard Mount Two Tone Bike Seat
Misc.:	Water Bottle Holder Front Mounted Transport Wheels 4 Adjustable Foot Pads for Leveling	Water Bottle Holder Front Mounted Transport Wheels 4 Adjustable Foot Pads for Leveling
Max. User Weight:	300 lbs	300 lbs.

Limited Home Use Warranty

The LifeSpan Sport S1/S2 Indoor Bike(s) come with the following limited warranty, which applies only to the use of the Indoor Bike in the home, for residential, non-commercial purposes:

	S1	S2
Frame:	5 years	5 years
Parts:	90 days	1 year
Labor:	90 days	1 year
Wear Items:	90 days	90 days (friction pad, seat and pedals)

PCE Health and Fitness warrants that the equipment it manufactures is free from defects in material and workmanship under normal use and service. The periods above are based on the date of purchase. During these periods, PCE Health and Fitness will repair or replace any defective part. Free labor is included (see details above) for parts that are not considered customer repairable. For instance, seats and pedals are considered customer repairable and do not require a technician.

If within the time frames specified above, any part of the LifeSpan Sport S1/S2 Indoor Bike fails to operate properly, contact your authorized LifeSpan retailer or log into our web site at www.lifespanfitness.com and click on the Customer Support menu item. Be prepared to provide the product serial number, date of purchase, and a description of the problem to ensure accurate and quality care from one of our customer service advisors.

PCE Health and Fitness reserves the right to make changes and improvements in our products without incurring any obligations to similarly alter any product purchased. In order to insure our product warranty and to ensure the safe and efficient operation of your Indoor Bike, only authorized parts should be used. This warranty is void if any parts other than those provided by PCE Health and Fitness are used.

Exclusions and Limitations

- This warranty does not apply to any defects caused by negligence, misuse, improper assembly or maintenance, accident, or an "act of god".
- This warranty does not apply to discoloration of paint or plastics.
- PCE Health and Fitness shall not be responsible for incidental or consequential damages.
- This warranty is nontransferable from the original owner.
- Labor warranty does not cover replacement of customer assembled parts.

Registration

You must register your LifeSpan product before a warranty claim can be processed. To complete your registration online, go to www.lifespanfitness.com and fill out the registration or fill out the warranty card provided with your bike and mail it today. Registration cards must be completed and sent to PCE Health and Fitness within 30 days of purchase to activate the Product Warranty on your LifeSpan Sport equipment. Product warranties are not valid unless the registration is properly completed and sent to PCE within 30 days of purchase.

Important Safety Precautions

S1/S2 Sport Series

Indoor Bike

When using equipment, basic precautions should always be followed, including:

- Never operate your indoor bike if it has been damaged.
- Do not operate outdoors, near swimming pools or in areas of high humidity.
- Only operate this indoor bike on a solid stationary surface.
- Only use this product for its intended use as described in this Owners Manual.
- Do not use attachments that are not recommended by PCE Fitness.
- Wear shoes with rubber or high traction soles. Do not use shoes with heels, leather soles, cleats or spikes.
- Keep hands and feet away from moving parts.

Children and Pets









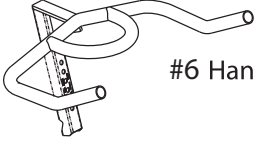

- Keep children off your indoor bike at all times.
- When in use, young children and pets should be kept at least 10 feet away.

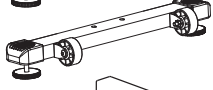
Other Safety Tips

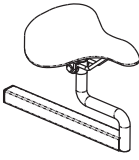
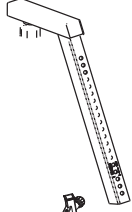
- Always consult a physician before beginning this or any exercise program.
- If you experience chest pains, nausea, dizziness or shortness of breath, stop exercising immediately and consult your physician before continuing.

Note: Read ALL instructions before using your LifeSpan Sport Indoor Bike.
Save these instructions

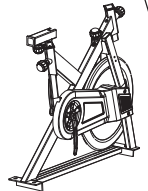
S1 Contents

 #19 Washers x4	 #6 Handle Bar x1	 #9 Rear Base x1
 #18 Screw x 4		 #8 Front Base x1 (with wheels)
 #20 Multi-function Wrench	 #3 Seat and Post x 1	 #2 Seat Bracket
 #21 Allen Wrench	 #10 Left pedal x 1	
 #16 Water Bottle Holder x 1	 #12 Right Pedal x 1	 #1 Main Frame Assembly
 Plastic Block x 2 (for shipping only)		

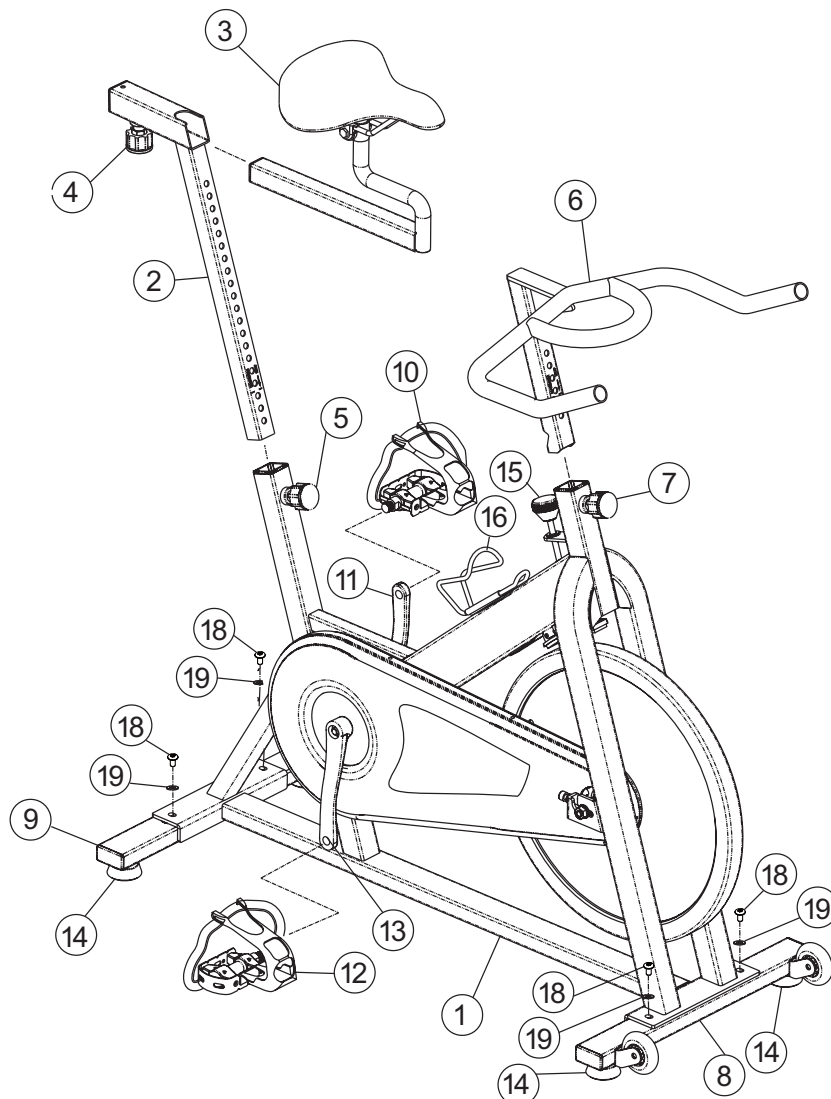

S1 Assembly Instructions

S1/S2 Sport Series

Indoor Bike

Warning: Unpacking and assembly requires two people.

Step 1: Attach Rear Base

- Remove plastic block attached to frame for protection during shipping.
- Remove bolts (18) and washers (19) from the rear base.
- Stand the main frame assembly upright with the rear base (9) positioned underneath the frame.
- Insert two bolts (18) with washers (19) down through the holes in the frame and into the rear base.
- Once both bolts are started, securely tighten rear base (9) to frame.

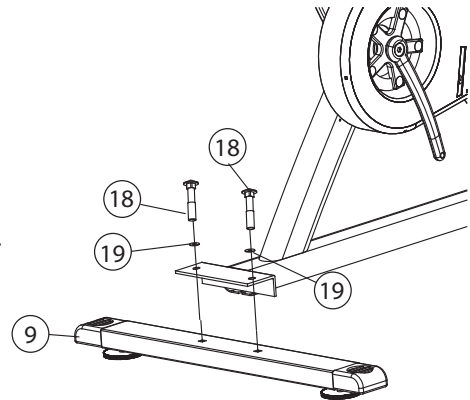

Step 2: Attach Front Base

- Remove plastic block attached to frame for protection during shipping.
- Remove bolts (18) and washers (19) from the front base.
- Position the front base underneath the frame.
- Insert the two bolts (18) with washers (19) down through the holes in the frame and into the front base (8).
- Once both bolts are started, securely tighten the front base (8) to the frame.

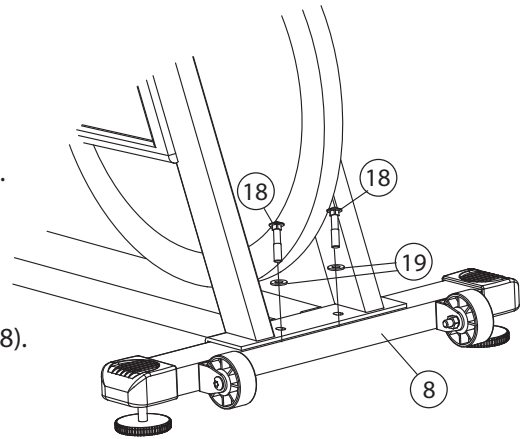

Step 3: Attach Pedals

Caution: DO NOT USE WRENCH TO START THREADING PEDAL

- Identify which pedal goes on the right side and which pedal goes on the left side by locating the "R" on the bolt of the right pedal (12) and the "L" on the bolt of left pedal (10).
- Hand tighten the right pedal into the right crank arm by turning **clockwise**.
- Hand tighten the left pedal into the left crank arm by turning **counter clockwise**. Be careful not to cross thread the threads.
- Tighten both pedals with the multifunction wrench (20).

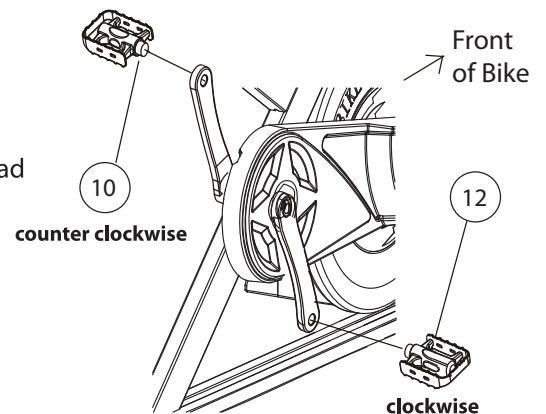

Round Adjustment Knob Instructions

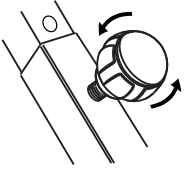
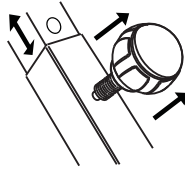
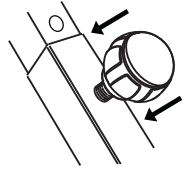
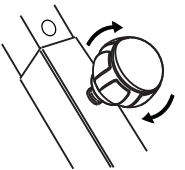
 <p>1 Turn knob counterclockwise to loosen</p>	 <p>2 Pull knob out to release pin, make desired adjustment</p>
 <p>3 Release knob, make sure pin locks in hole</p>	 <p>4 Turn knob clockwise to tighten</p>

Step 4: Install Handlebars

- a) Loosen the knob (7) in the front of the frame. (follow round adjustment knob instructions above)
- b) Insert handlebar post (6) into the frame, with holes facing out toward knob. Adjust height and tighten knob (7). (follow round adjustment knob instructions above)

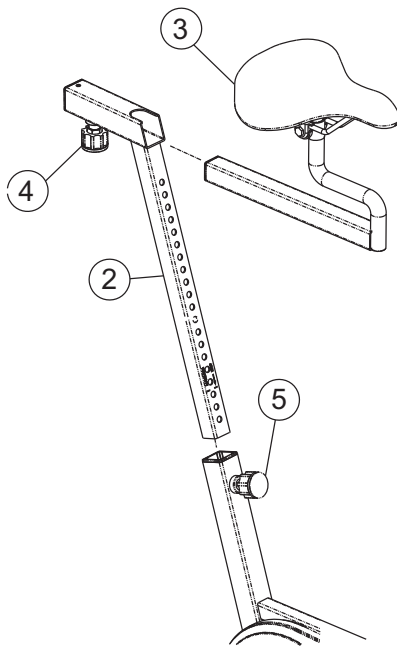
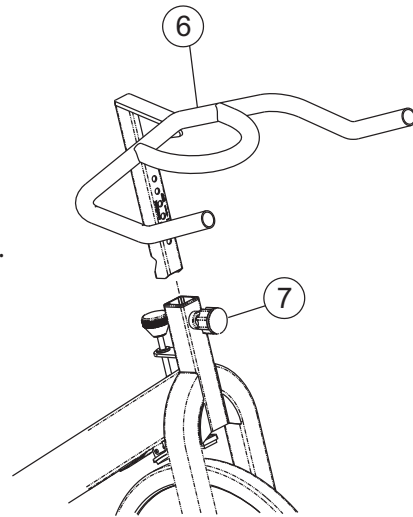









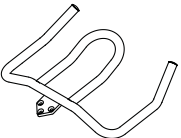
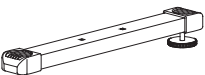

Step 5: Install Seat

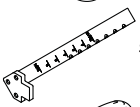
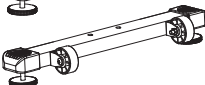
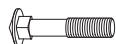
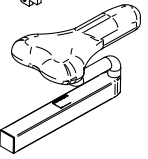
- a) Loosen the knob (5) on the front of the frame and slide the seat bracket (2) into the frame. (follow the round adjustment knob instructions above)
- b) Loosen the knob (4) on the bottom of the seat bracket (2) and slide the seat post (3) into the seat bracket. (follow the round adjustment knob instructions above)

S2 Contents

S1/S2 Sport Series

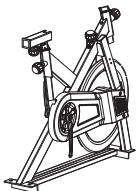
Indoor Bike

 #56 Cap Nuts x4	 #22 Handle Bar x1	 #52 Rear Base x1
 #55 Washers x4	 #16 Handle Bar Post x1	 #53 Front Base x1 (with wheels)
 #57 Bolt x4	 #63 Seat and Post x 1	 1 Multi-function Wrench
 #21 Handlebar Bolt x 3	 #64 Water Bottle Holder x 1	 1 Allen Wrench
 Block x1 (for shipping only)	 #62L Left pedal x 1	 #10 Main Frame Assembly
	 #62R Right Pedal x 1	

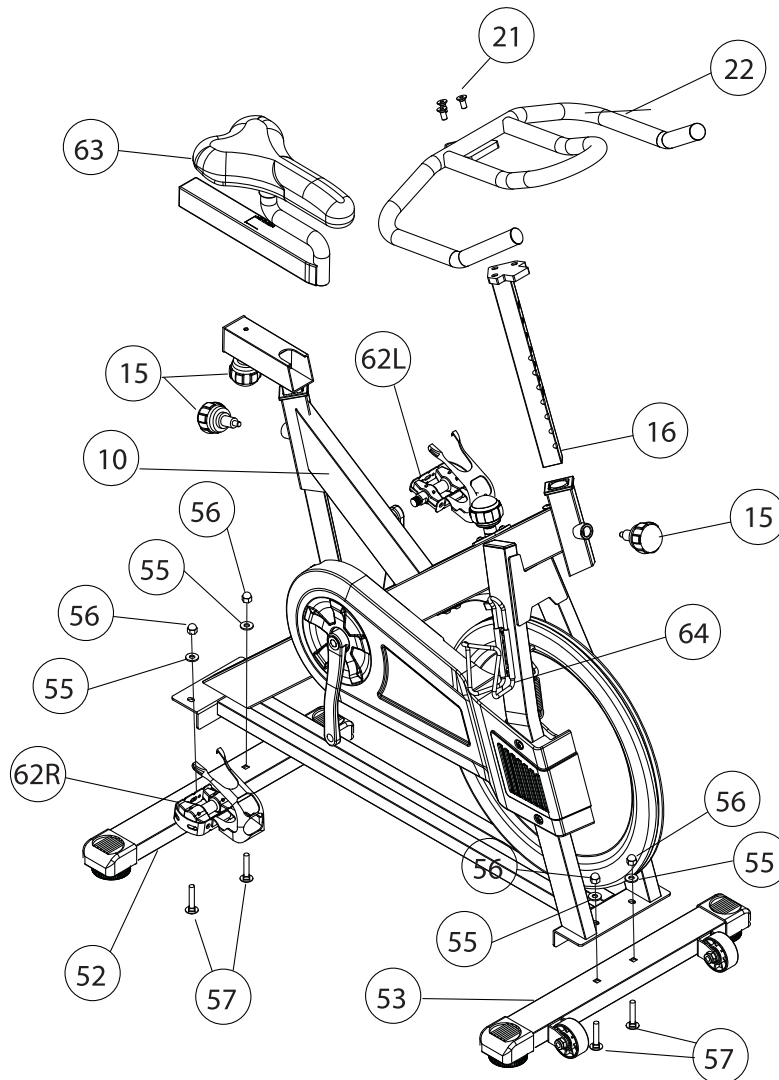

S2 Assembly Instructions

Warning: Unpacking and assembly requires two people.

Step 1: Attach Rear Base

- Stand the main frame assembly upright with the rear base (52) positioned underneath the frame.
- Insert two bolts (57) from underneath the rear base and through the holes in the frame.
- Place a washer (55) and cap nut (56) over each bolt and with the multifunction wrench secure the rear base in place.

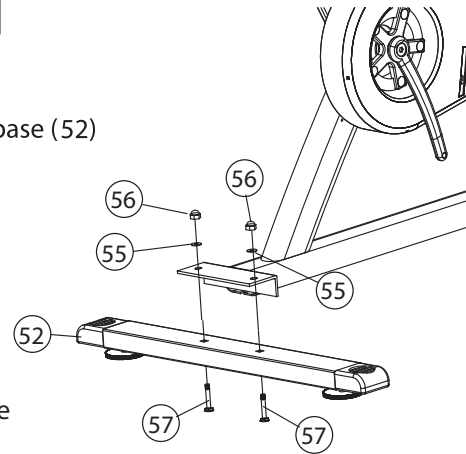

Step 2: Attach Front Base

Helpful hint: Use a second person to lift frame while attaching front base.

- Position the front base (53) underneath the frame.
- Insert the two bolts (57) from underneath the front base and through the holes in the frame.
- Place a washer (55) and cap nut (56) over each bolt and with the multifunction wrench secure the front base in place.

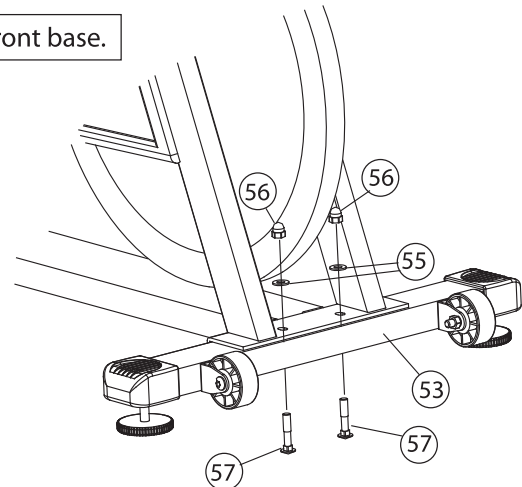

Step 3: Attach Pedals

Caution: DO NOT USE WRENCH TO START THREADING PEDAL

- Identify which pedal goes on the right side and which pedal goes on the left side by locating the "R" on the bolt of the right pedal (62R) and the "L" on the bolt of the left pedal (62L).
- Hand tighten the right pedal into the right crank arm by turning **clockwise**.
- Hand tighten the left pedal into the left crank arm by turning **counter clockwise**. Be careful not to cross thread the threads.
- Tighten both pedals with the multifunction wrench.

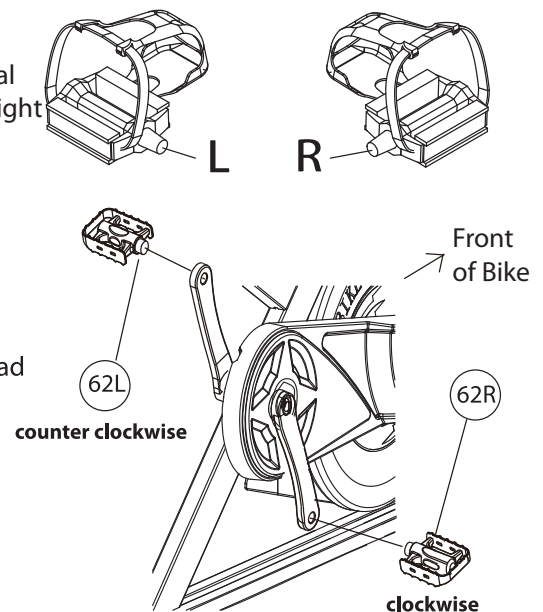

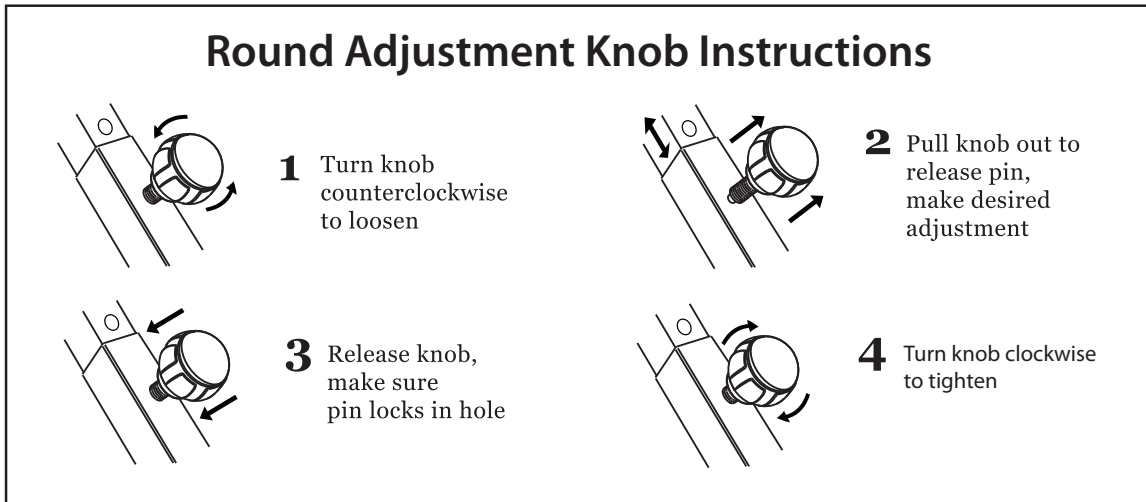

Step 4: Install Handlebars

- a) Loosen the knob (15) in the front of the frame. (follow round adjustment knob instructions above)
- b) Insert handlebar post (16) into the frame with holes facing out toward knob. Adjust height and tighten knob (15). (follow round adjustment knob instructions above)
- c) Place the handlebars (22) on top of the supporting bracket and align three bolt holes.
- d) Install three bolts (21) and tighten with wrench provided.

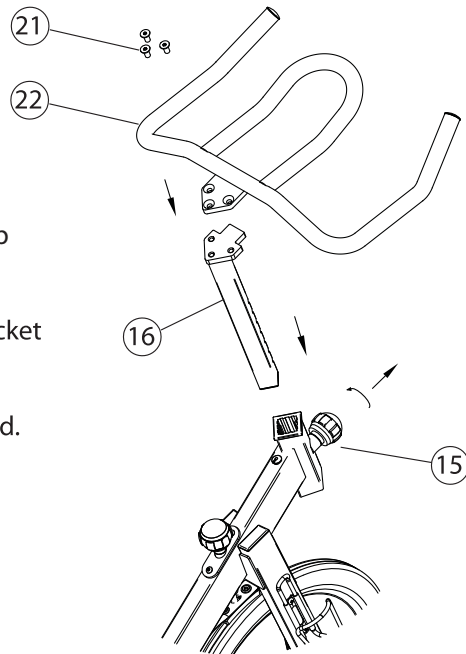

Step 5: Install Seat

- a) Loosen the knob (15) on the bottom of the seat bracket (17). (follow round adjustment knob instructions above)
- b) Slide seat post (63) into the seat bracket (17) from the front of the bracket as illustrated. (follow round adjustment knob instructions above)

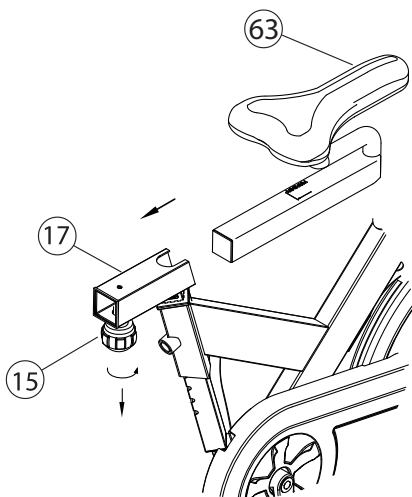

Where to Place your Indoor Bike

Place your Indoor Bike in a pleasant area that gives you something to look at while you're working out, such as a window or television. Maintaining an exercise program in a poorly lit area is more difficult than when located in a pleasant and active location.

Stabilizing Your Exercise Bike

After you have placed the bike where you will be using it, check the stability by rocking it back and forth in all directions. Any movement indicates that the bike needs to be leveled. First determine which foot is not resting on the floor. Adjust the foot down until it touches the floor. Repeat if necessary until the bike is completely stable.

Seat Adjustment

Before working out, make sure that the seat is properly adjusted. Do this by sitting on the seat and placing the balls of your feet on the pedals. Your knee should be slightly bent when the pedal is at the furthest point of rotation from your body. You should be able to pedal without locking your knee or shifting in the seat.

Pedal Straps

The straps should be tight enough to keep the ball of your foot on the pedals throughout the complete pedal rotation. Before your workout, test each strap and adjust if required. To tighten the strap simply pull down on the loose end of the strap until the strap is properly tensioned. To loosen the strap, press down on the top of the clip and pull the strap up.

S1 Exploded View

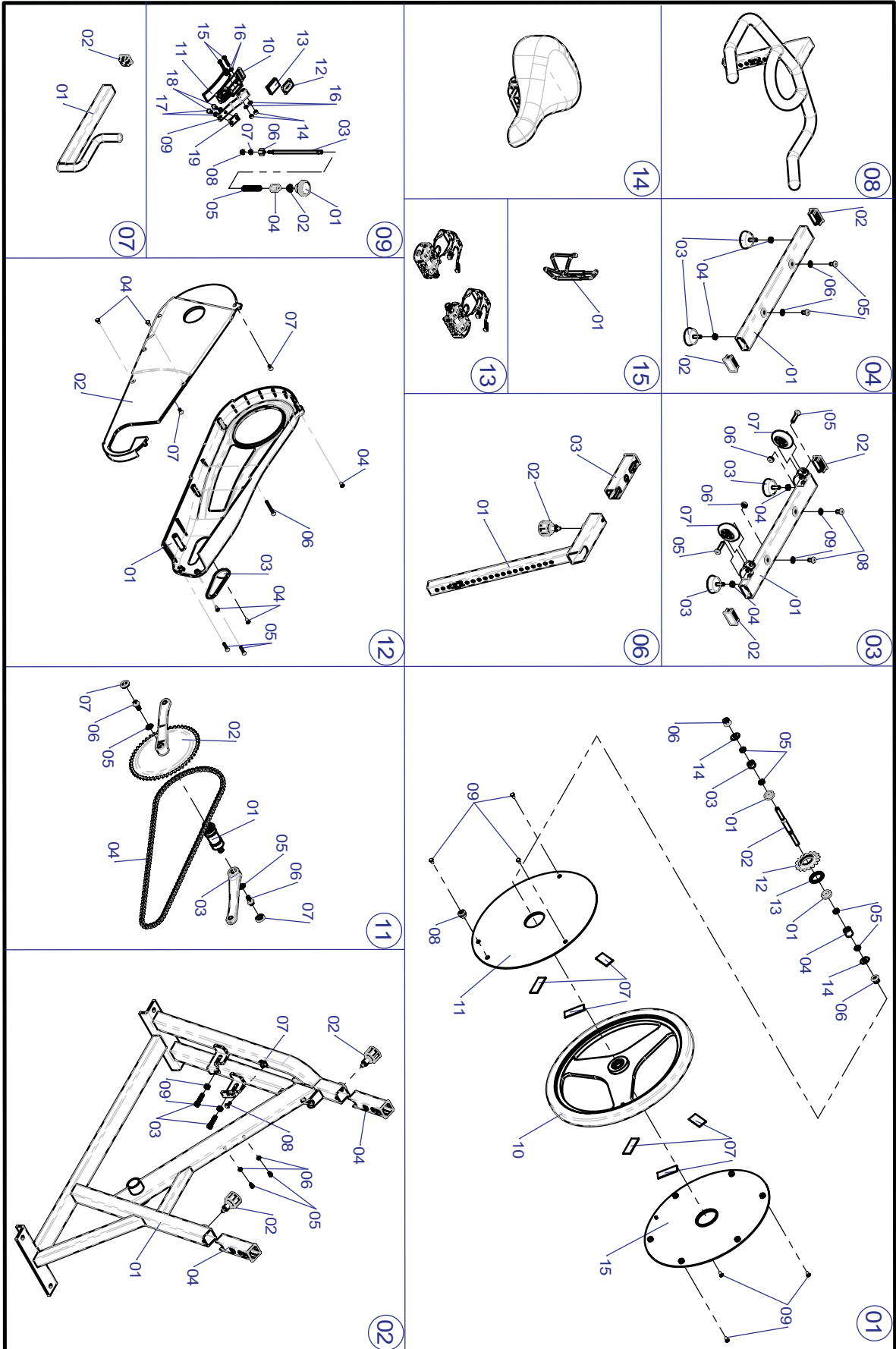

S2 Exploded View

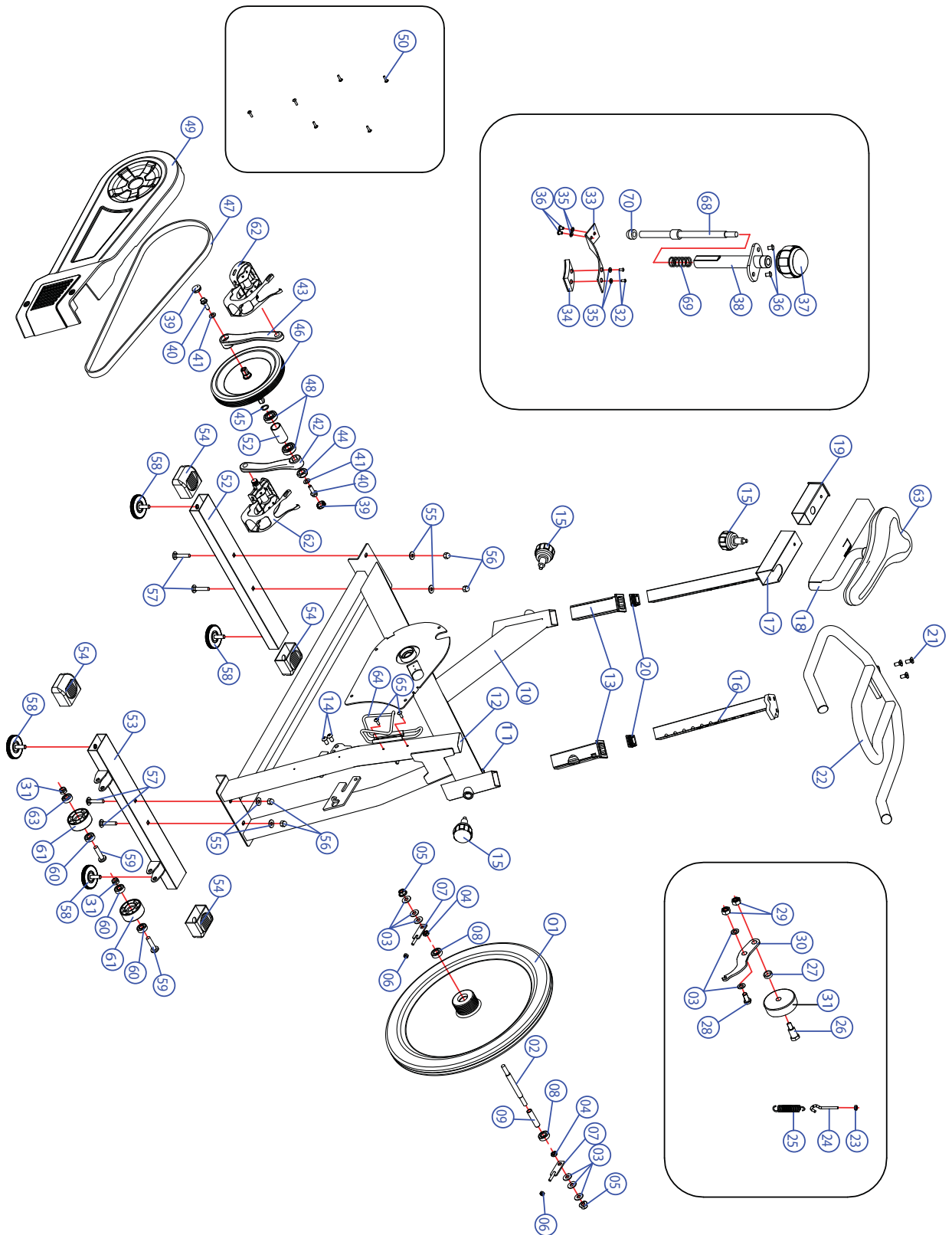

S1/S2 Sport Series

Indoor Bike

LifeSpan™

Treadmill Doctor

The Most Trusted Name In
Fitness Equipment

Extended Service Plans

360°
GUARANTEE

Up to **4 Years of Coverage**
for just **Pennies a Day**

Treadmill Doctor's 360 Degree Guarantee

Extended Service Plan program is a money saver for YOU!

- ✓ We will Extend your original Manufacturer's warranty for parts & labor coverage.*
- ✓ We will cover failures due to normal wear and tear.*
- ✓ We will replace your machine if we can't repair it.*
- ✓ We provide unlimited on-site visits!*
- ✓ We will cover failures due to power surges.
- ✓ Your coverage is transferable.
- ✓ Over 3,000 certified technicians.
- ✓ National toll-free repair hotline.
- ✓ Simple repair claim procedure & no claim forms.

Did You Know

a single repair can cost TWICE the amount of a 3 year service plan?

That is because a single repair is not one service trip it is two! One trip for the diagnosis and one for the repair after parts have been ordered.

Labor Cost	-\$260
Parts Cost	-\$170
Total Repair Cost	-\$430

3 Year Treadmill Doctor
Service Plan **\$169.99**

Get your 360 Guarantee NOW

ONE OF THE INDUSTRY'S BEST GUARANTEES!

Copyright © 2010, TreadmillDoctor.com, Inc. All rights reserved. Treadmill Doctor and 360 Degree Guarantee are registered trademarks of TreadmillDoctor.com, Inc. All rights reserved.

Enroll Now:

360guarantee.com/Lifespan

You will need the following information:

- Purchase Date*
- Model Number*
- Serial Number*
- Retailer/ Etailer Name
- * Required Field

Purchase Price	1 Year	2 Year	3 Year	4 Year
\$300-\$999	\$99.99	\$129.99	\$169.99	\$229.99
\$1000-\$1999	\$129.99	\$149.99	\$229.99	\$299.99
\$2000-\$2999	\$169.99	\$199.99	\$299.99	\$399.99
\$3000-\$3999	\$199.99	\$249.99	\$399.99	\$499.99
\$4000-\$4999	\$299.99	\$399.99	\$599.99	\$899.99



LifeSpan Fitness
785 West 1700 South
Salt Lake City, UT 84104

* Limitations and exclusions apply. See terms and conditions available online at 360guarantee.com/Lifespan for full agreement details.

Contract begins at the expiration of the manufacturer's labor warranty.

TREADMILL MODEL NUMBER- ***S1/S2***

SERIAL NUMBER :

MADE IN TAIWAN