

WARING PRO[®]

PROFESSIONAL TOASTER OVEN/TOASTER

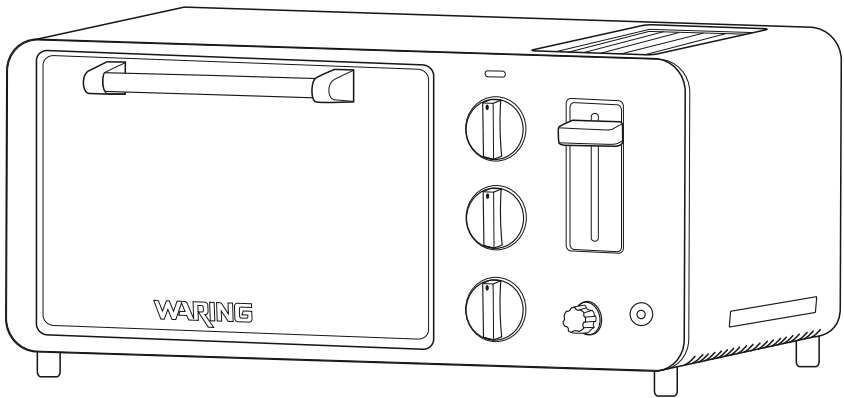

WTO150

For your safety and continued enjoyment of this product,
always read the instruction book carefully before using.

IMPORTANT SAFEGUARDS

SAVE AND READ THESE INSTRUCTIONS

When using electrical appliances, basic safety precautions should always be followed, including the following:

1. **READ ALL INSTRUCTIONS.**
2. **Unplug from outlet when not in use and before cleaning. Allow to cool before putting on or taking off parts, and before cleaning.**
3. Do not place anything on top of the oven.
4. Close supervision is necessary when any appliance is used by or near children.
5. To protect against electric shock, do not immerse cord, plug, or any parts of the oven in water or other liquids.
6. Do not operate appliance with damaged cord or plug, or after the appliance malfunctions or has been damaged in any manner. Return appliance to the nearest Authorized Service Center for examination, repair, or adjustment.
7. The use of accessory attachments not recommended by the appliance manufacturer may cause hazard or injury.
8. Do not use outdoors.
9. Do not place on or near a hot gas or electric burner, or in a heated oven.
10. Do not let the cord hang over the edge of table or counter, or touch hot surfaces, including the stove.
11. When operating the oven, keep at least four inches of space on all sides of the oven to allow for adequate air circulation.
12. To disconnect, turn the Timer control to OFF, then remove the plug. Always hold the plug, never pull the cord.

13. Extreme caution must be used when moving an appliance containing hot oil or other hot liquids.
14. Do not clean with metal scouring pads. Pieces can break off the pad and touch electrical parts, creating a risk of electric shock.
15. Extreme caution should be used when using containers other than metal or glass.
16. Do not cover crumb tray or any part of the oven with metal foil. This will cause overheating. Foil can be used to cover approved cooking containers. Do not place any of the following materials in the oven: cardboard, plastic, paper, or anything similar.
17. Do not put face in close proximity with the tempered safety glass door, in the event that the safety glass breaks.
18. Use extreme caution when removing trays or disposing of hot grease or other hot liquids.
19. Do not store any materials, other than manufacturer's recommended accessories, in this oven when not in use.
20. This appliance is off when the Timer/Toast Shade and Function controls are in the OFF position. When not in use, the oven should always remain unplugged from the wall outlet.
21. Always wear protective, insulated oven mitts when inserting or removing items from the hot oven.
22. This appliance has a tempered safety glass door. The glass is stronger than ordinary glass and more resistant to breakage. Tempered glass can break, but the pieces will not have sharp edges. Avoid scratching door surface or nicking edges. If the door has a scratch or nick, contact our toll-free Customer Service line at 1-800-492-7464 before using the oven.
23. Do not use appliance for other than intended use.

24. Do not cook, warm, or toast rice cakes, fried foods, non-bread items or toaster pastries in your toaster. Toaster pastries should be heated in the toaster oven broiler. Do not toast any food product that has been spread with margarine, butter, jelly, frosting, syrup, or other spread.
25. Oversized foods or metal utensils must not be inserted in the appliance, as they may create a fire or risk of electric shock.
26. Never cover toaster or toast slots during operation.
27. Do not operate while unattended.
28. Do not touch hot surfaces. Use handles or knobs.
29. Do not attempt to dislodge food when toaster is plugged in.
30. Do not operate your appliance in an appliance garage or under a wall cabinet. **When storing in an appliance garage always unplug the unit from the electrical outlet.** Not doing so could create a risk of fire, especially if the appliance touches the walls of the garage or the door touches the unit as it closes.

SAVE THESE INSTRUCTIONS FOR HOUSEHOLD USE ONLY

ADDITIONAL SAFETY INFORMATION

A short power-supply cord is provided to reduce the hazards resulting from entanglement or tripping over a longer cord. If it is necessary to use an extension cord, it should be positioned so that it does not drape over the counter or tabletop where it can be pulled on by children or tripped over.

An extension cord may be used if care is exercised in its use.

NOTE: The marked rating of the extension cord must be equal to or greater than the rating of this appliance. The electrical rating is listed on the bottom of this unit.

Important: This oven is rated 1500 watts. Be sure this is the only appliance operating on the circuit.

NOTICE:

This appliance has a polarized plug (one blade is wider than the other). To reduce the risk of electric shock, this plug is intended to fit into a polarized outlet only one way. If the plug does not fit fully into the outlet, reverse the plug. If it still does not fit, contact a qualified electrician. Do not attempt to modify the plug in any way.

NOTE: When using the oven/bake/toast function and the toaster function at the same time, the bottom oven heater will be turned off.

PARTS

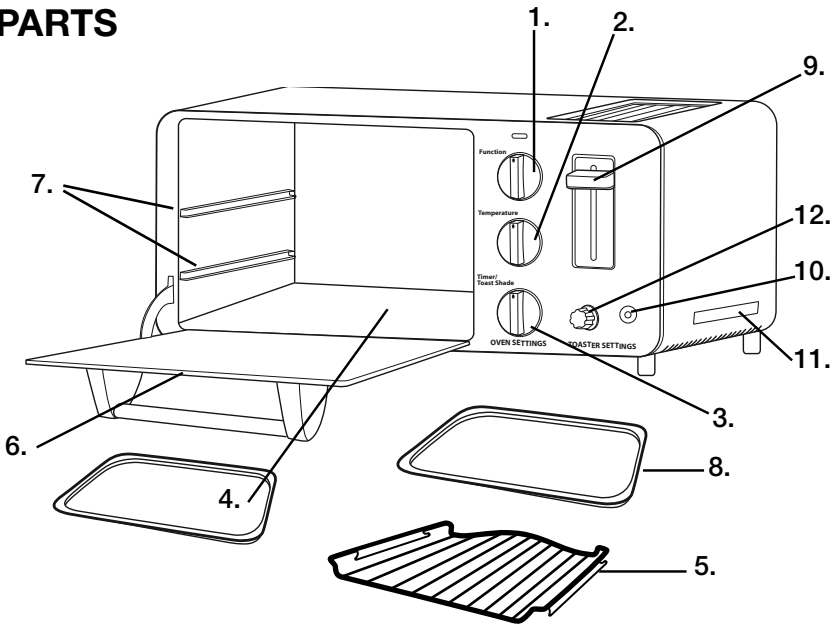

1. **Function Selector Dial** – Select cooking function by turning knob to desired setting.
2. **Temperature Control Dial** – Adjust the thermostat to the desired temperature.
3. **Timer/Toast Shade Control Dial with Bell Signal** – Set cooking time up to 30 minutes. Will automatically turn the oven off at the end of the cooking time.
4. **Removable Oven Crumb Tray** – Located at the bottom of oven. Collects crumbs or fallen food particles.
5. **Reversible Oven/Broil Rack** – See Oven Rack Position section, pages 9–10.
6. **Tempered Glass Door** – For front viewing of food.
7. **Two Rack Levels** – To accommodate a variety of foods.
8. **Baking Pan** – Use for all your baking and roasting needs. Attaches to oven/broil rack to broil.
9. **Carriage Lever**
10. **Bagel Button**
11. **Slide-out Toaster Crumb Tray**
12. **Toaster Shade Control**

BEFORE FIRST USE

Read all instructions in this manual carefully.

Place your oven on a level surface such as a countertop or table. Be sure the sides, back and top of the oven are at least four inches away from any walls, cabinets or objects on the counter or table.

Remove oven rack, baking pan and crumb trays (one from toaster side and one from oven side). Wash them in hot, sudsy water and dry thoroughly before placing in the oven.

When you are ready to use the oven, be sure that the Function and Timer/Toast Shade controls are in the OFF position. Plug the cord into a 120-volt AC outlet.

We recommend a “trial run” at a high temperature to familiarize yourself with your oven and to eliminate any protective substance or oil that may have been used for packing and shipping. Set the Temperature control to 400° F, the Timer/Toast Shade control to 15 minutes and the Function control to Toast or Bake to activate the oven’s heating element. After the first 10 minutes, switch the Temperature control to 450° F/Broil/Toast to activate the upper and lower heating elements. For the toaster, turn the Shade control to DARK and depress the carriage lever. A small amount of smoke and odor may be detected in both your oven and toaster during this trial run. This is normal.

To avoid scratching, marring, discoloration or fire hazard, do not store anything on top of the oven, especially during operation.

This appliance requires 1500 watts and should be the only appliance operating on the circuit.

GENERAL GUIDELINES

Baking: Baking function can be used as you would normally use your large kitchen oven for roasting meats including chicken, or baking cakes, cookies and more.

Broiling: Broiling function can be used for beef, chicken, pork, fish and more. It also can be used to top-brown casseroles and gratins. Caution: Aluminum foil is not recommended for covering the baking pan. Foil is extremely dangerous when broiling fatty foods. Grease will accumulate and may catch fire. The use of foil is not recommended, but if foil is used to cover baking pan, be sure foil is tucked neatly around it and does not touch the walls or heating rods. Never cover crumb tray.

Toasting: Always have the rack in the DOWN position B, as indicated in the diagram on page 9, for even toasting. Always center your item/items in the middle of the rack.

WARNING: Placing the rack in the top position with the rack upwards while toasting may result in a fire. Refer to rack position B on page 9 for proper placement.

Turning off the toaster oven broiler: Turn the Function and Timer/Shade controls to OFF. The indicator light will turn off.

OPERATION OF YOUR OVEN

Caution: Appliance surfaces are hot during and after use! Do not place anything on top of this appliance.

- Be sure that the Function and Timer/Toast Shade controls are turned to OFF before plugging the cord into the outlet before use and when unplugging the oven after use.
- Plug your appliance into a 120 volt AC outlet.
- Set the Temperature control and the Function control before setting the Timer/Toast Shade control.
- The oven will only operate if the Timer/Toast Shade control is turned to a time setting or if it is in the ON position.

Cooking Containers

- The bake tray included with the oven is suitable for cookies, rolls, biscuits, nachos, pork chops, etc. It may be easier to use a nonstick spray when using the bake tray or broil pan.
- Any oven-safe baking pans or casserole dishes are suitable for your Toaster Oven.
- Choose bakeware made of metal, oven-proof glass or ceramic.
- Many convenience foods are packaged in nonmetallic containers suitable for use in microwave ovens as well as a regular oven. **Check package directions carefully to determine if the container is suitable for use in a regular oven.**

USE AND CARE

Positioning Rack

Note: Rack must be in the UP position C to accommodate the bake tray and broil pan.

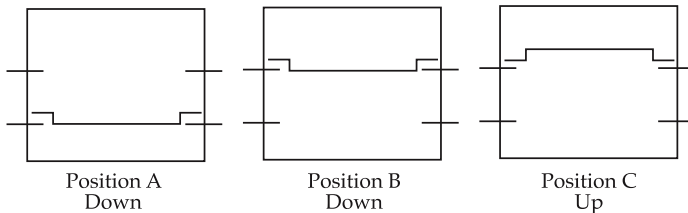

Check that the crumb trays are in place and that there is nothing in the oven. Plug power cord into the wall outlet.

Broil:

To broil most items, place rack in position C.

NOTE: Never use glass oven dishes to broil.

OPTION: To reduce the chance of sizzling or spattering, you may add approximately $\frac{1}{4}$ cup water to the bottom of the bake tray.

Attach baking pan to base of oven/broil rack by sliding the pan under the rack to fit into the metal brackets on the sides. Put food on rack and slide broiling assembly into upper rack guides in oven. Set Temperature and Function controls to Broil. It is not necessary to preheat oven on the broil function. **Always leave door ajar when broiling.** The oven indicator light will turn on. To stop broil operation, turn Function and Timer/Toast Shade controls to OFF, and turn Temperature control to MIN.

Bake:

To bake, turn the Function control to Bake position and Temperature control to desired temperature. The oven indicator light will turn on after the timer is set. Oven rack not required for use with baking pan. Simply slide baking pan into position.

Preheat oven for five minutes, then begin to bake. Timer: To use the timer, set the knob to the desired time, up to 30 minutes. To set the timer less than 20 minutes, turn the knob past the 20-minute mark, then back to desired bake time.

Toast – Oven Side:

To toast, make sure the oven rack is in the rack position B, as indicated in the diagram on page 9. If toasting two items, center them in the middle of the rack. Four items should be evenly spaced – two in front, two in back. Close the glass door.

Toast/Shade Selection:

Set Function control to Toast. Set Temperature control to Toast. Turn Timer/Toast Shade control to desired toast/shade setting. The indicator light will turn on. Timer: Turn the timer past the 20-minute mark then back to desired toast time anywhere between the toast symbols.

Stop Toasting – Oven Side:

When the toasting cycle is finished, the oven bell will sound and turn off. If you wish to stop the toasting cycle before it is

finished, turn Timer/Toast Shade control to OFF, which will cancel your toast cycle.

Important Notes on Toasting:

The oven rack must be in rack position B as indicated in the diagram on page 9.

OPERATION OF YOUR TOASTER

1. Place bread in slots. Turn Shade control to preferred shade and press down on the carriage lever.
2. At the end of the toasting cycle, the bread will pop up automatically. To stop the toasting cycle sooner, turn Shade control dial counterclockwise to Cancel; **do not force the carriage lever up.**
NOTE: The carriage lever will not stay down unless the toaster is plugged in.
3. For bagels, set the Timer/Toast Shade control to desired level, depress the carriage lever, and press the Bagel button. The Bagel feature will evenly toast both sides of the bagel.

TOASTER CONTROLS

Shade Control – Sets desired toast color from light to dark.

Bagel Button – Adds extra time to toasting cycle and will toast both sides of the bagel. Slide-out Crumb Tray – Pull out to clean crumbs that collect in bottom of toaster (see Parts diagram, page 6).

HELPFUL HINTS

- Toast shades are affected by many things, such as whether or not the bread has been refrigerated or is at room temperature, the moisture content of the bread, thickness, density, bagels vs. English muffins, etc. Some bread will require different toasting shades, or two toasting cycles to achieve your desired results.

CARE AND CLEANING

1. Turn the Function control to OFF and the Timer/Toast Shade control to OFF and unplug before cleaning. Wait until your oven and toaster have completely cooled before cleaning.
2. Clean the outside of the oven with a damp cloth and dry thoroughly. Clean stubborn stains with a nonabrasive liquid cleaner. Rinse and dry thoroughly. Do not use metal scouring pads or abrasive cleaners that will scratch the surface.
3. Clean the glass door with a cloth or sponge dampened with warm, sudsy water and dry thoroughly.
4. Wash the oven rack, bake tray, broil pan and toaster crumb trays in hot sudsy water. **NOTE:** These parts are not dishwasher safe. Please hand wash and dry.
5. Blot dry with a paper towel or soft, dry cloth.
6. DO NOT use cleaning agents, cleansers or metal scouring pads.
7. Empty the toaster crumb tray, which is located on the side of the toaster and the oven crumb tray, which is located on the inside bottom of oven.
8. Any other servicing should be performed by a Waring Authorized Service Representative or call Waring Customer Service at 800-492-7464.

Trademarks or service marks of third parties used herein are the trademarks or service marks of their respective owners.

©2011 Waring Consumer Products
150 Milford Road
East Windsor, NJ 08520

www.waringpro.com

Printed in China
WTO150 IB

11WR125070

IB-9032A