

COASTER
FINE FURNITURE®

120519

24" BARSTOOL

ASSEMBLY INSTRUCTION
COASTER FINE FURNITURE



www.coastercompany.com

Assembly Instruction

ASSEMBLY TIPS:

1. Remove hardware from box and sort by size.
2. Please check to see that all hardware and parts are present prior to start of assembly.
3. Please follow attached instructions in the same sequence as numbered to assure fast & easy assembly.

⚠ Warning!

1. Don't attempt to repair or modify parts that are broken or defective. Please contact the store immediately.
2. This product is for home use only and not intended for commercial establishment.

PARTS IDENTIFICATION

(A)



COMPLETE SEAT

1 PCS

(B)

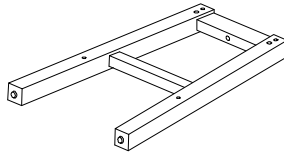

LEG

2 PCS

(C)

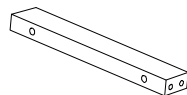

SMALL CROSS BAR

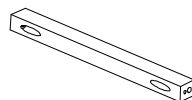

2 PCS

(D)

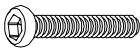
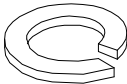

LARGE CROSS BAR

2 PCS

| Z | HARDWARE IDENTIFICATION | | |
|---|-------------------------|---|-------|
| 1 | ALLEN WRENCH M5mm |  | 1PC |
| 2 | BOLT Ø5/16"x1-3/4" |  | 4PCS |
| 3 | LOCK WASHER Ø5/16" |  | 4PCS |
| 4 | WOOD CAP 19mm×R15MM |  | 4PCS |
| 5 | SCREW Ø 8x1-1/2" |  | 10PCS |

STEP 1

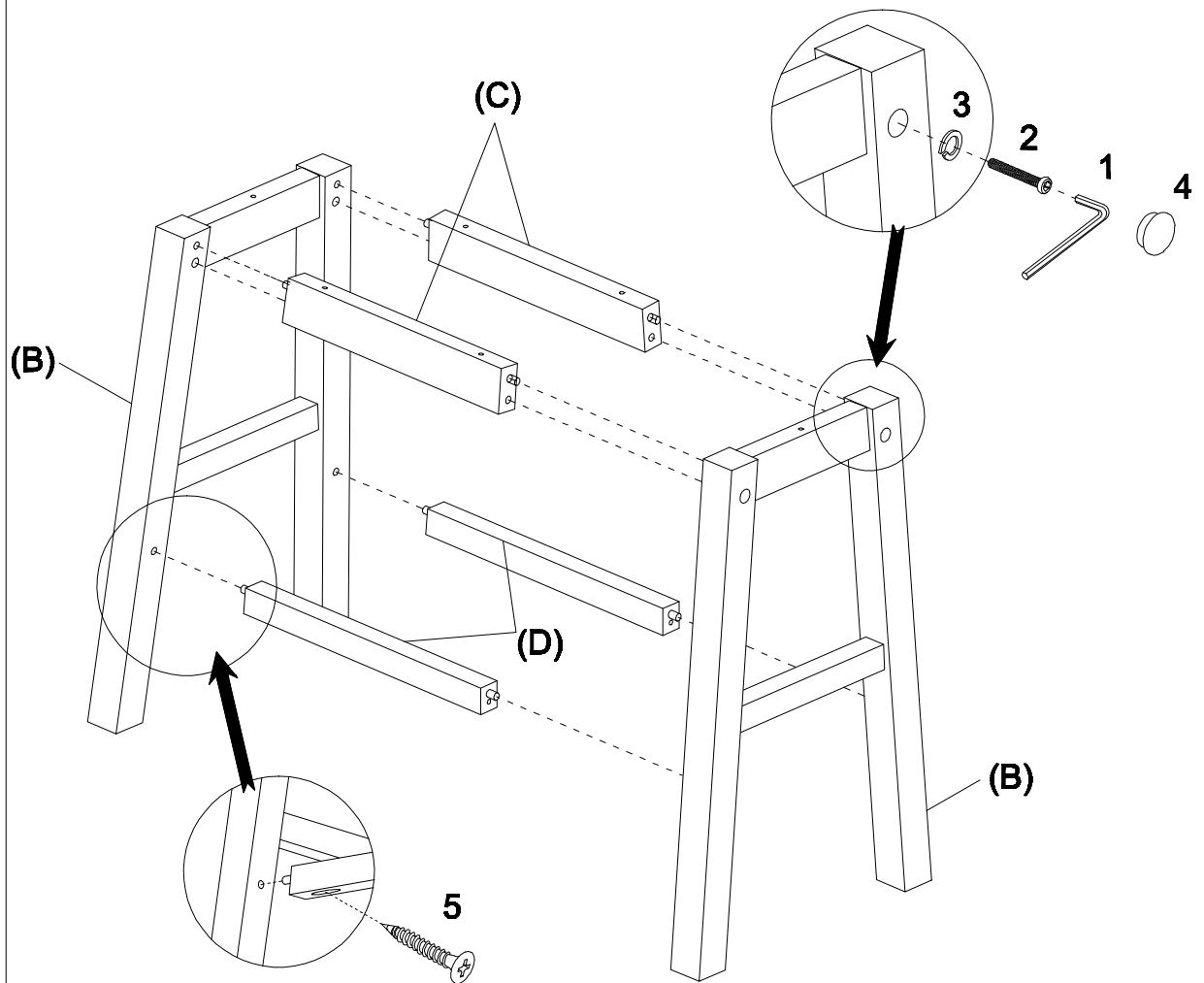

Insert the wood dowel into the cross bar. Use lock washer and bolts to secure cross bar to legs. Then insert the wood caps

STEP 2

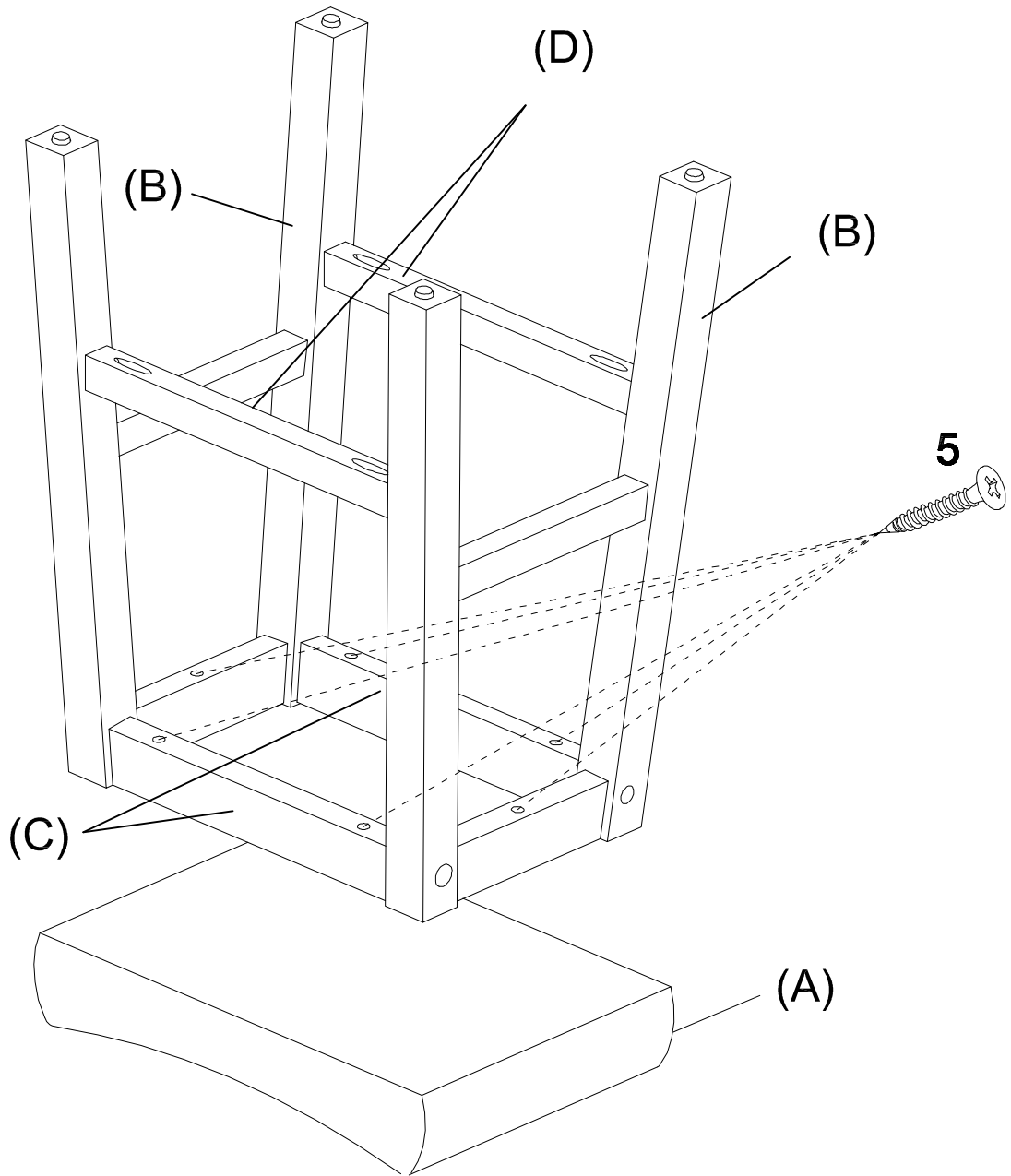

Use screws to secure legs to the seat. Tighten all bolts and screws with Allen Wrench.

STEP 3

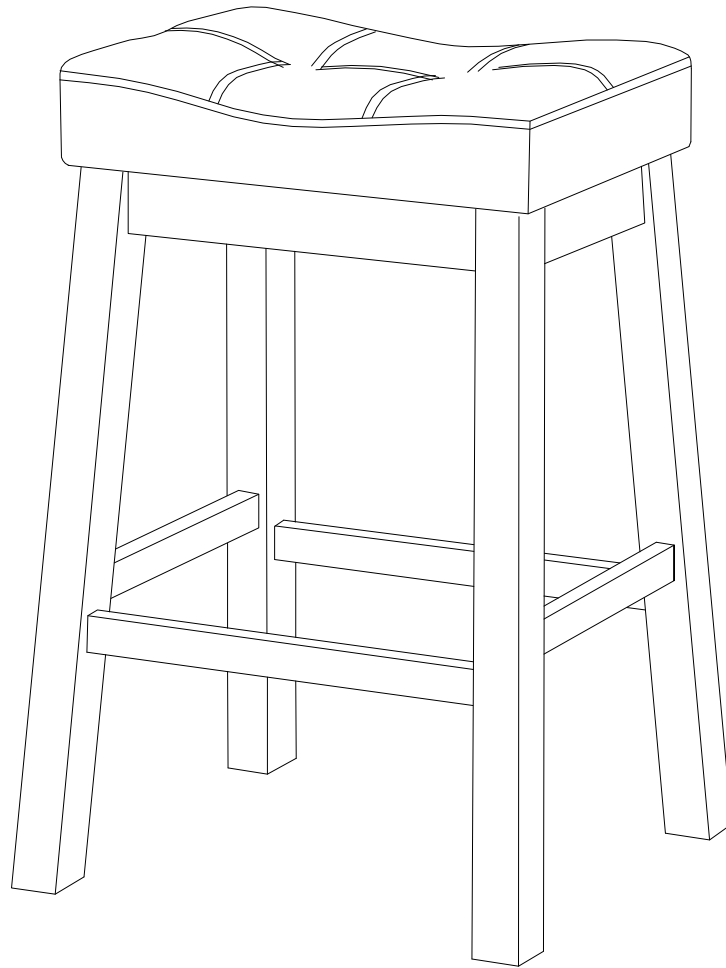

Assembly completed