

Tools Required:

- 4mm hex key
- 11/32" Nut driver
- Phillips medium screwdriver

CSA certified to U.S. and Canadian standards.
Suitable for wet locations.

Protection Class: IP65

Weight: 6.61 lbs.

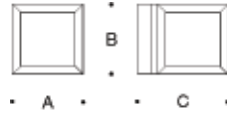

Dimensions

- A:** 6-1/4 "
- B:** 6-1/4 "
- C:** 8-1/4 "



Notice to Installer for 2453LED:

1. This product must be installed in accordance with the applicable installation code by a person familiar with the construction and operation of the product and the hazards involved.
2. Mounts directly to wall over standard octagonal 4" wiring box (by others).
3. Integral LED module and driver provided by BEGA within luminaire housing.

2453LED - installation:

1. Loosen (2) 4mm housing hex screws and remove outer casting and lens.
2. Make supply wiring and luminaire wiring connections in the wiring box:
 MAIN VOLTAGE SUPPLY WIRE TO BLACK LUMINAIRE WIRE
 NEUTRAL (COMMON) SUPPLY WIRE TO WHITE LUMINAIRE WIRE
 Dimming (if applicable):
 DIMMING CONTROL WIRE (+) TO POSITIVE DRIVER DIM CONTROL WIRE
 DIMMING CONTROL WIRE (-) TO NEGATIVE DRIVER DIM CONTROL WIRE
3. Place a small bead of silicone around the back side of the luminaire base that will come in contact with the finished wall (exterior applications only).
4. Attach the housing directly to the wall over a 4" standard octagonal wiring box using hardware (by others) see Figures for details.
5. Replace outer casting and glass and tighten (2) screws, making sure the gasket is seated properly.

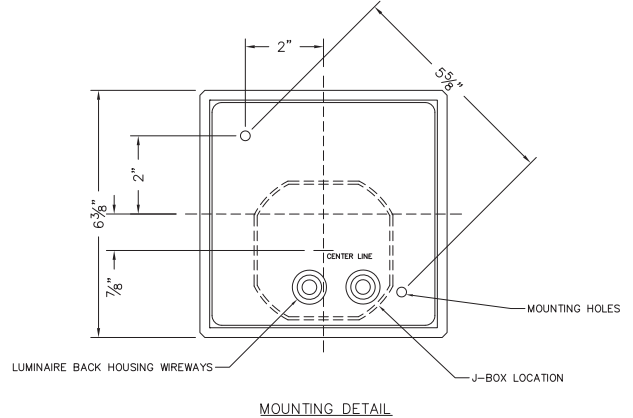
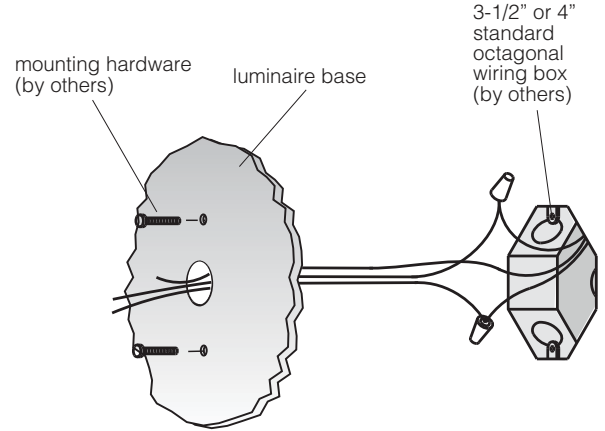

Relamping/Maintenance

No relamping required.

Accessories

Please refer to the appropriate accessory installation sheet for further instruction when applicable.

Replacement Parts

Description	Part No
Lens	11281411
Lens gasket	830535
LED module	LED-0263/830
LED driver	75929

Lamp: 6.6W LED module

In the interest of product improvement, BEGA reserves the right to make technical changes without notice.