

**Tools Required:**

- 3mm hex key
- 11/32" Nut driver
- Phillips medium screwdriver

CSA certified to U.S. and Canadian standards.  
Suitable for wet locations.

**Protection Class:** IP65

**Weight:** 3.20 lbs.

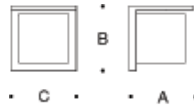

**Dimensions**

- A:** 4-3/4 "
- B:** 4-3/4 "
- C:** 5-5/8 "



**Notice to Installer for 3327LED:**

1. This product must be installed in accordance with the applicable installation code by a person familiar with the construction and operation of the product and the hazards involved.
2. Mounts directly to a standard octagonal 4" wiring box (by others) using mounting kit (supplied).
3. Integral LED module and driver provided by BEGA within luminaire housing.

**3327LED - installation:**

1. Loosen (2) 3mm housing hex screws and remove outer casting and lens.
2. Install (2) long 8-32 x 1 1/2" mounting screws (provided) in the back of the adapter plate as shown.
3. Attach adapter plate to wiring box using (2) 8-32 x 1/2" screws provided. Feed luminaire wires through luminaire base and around adapter plate.
4. Make supply wiring and luminaire wiring connections in the wiring box:  
 MAIN VOLTAGE SUPPLY WIRE TO BLACK LUMINAIRE WIRE  
 NEUTRAL (COMMON) SUPPLY WIRE TO WHITE LUMINAIRE WIRE  
 Dimming (if applicable):  
 DIMMING CONTROL WIRE (+) TO POSITIVE DRIVER DIM CONTROL WIRE  
 DIMMING CONTROL WIRE (-) TO NEGATIVE DRIVER DIM CONTROL WIRE
5. Place a small bead of silicone around the back side of the luminaire base that will come in contact with the finished wall (exterior applications only).
6. Attach luminaire base to adapter plate over the mounting screw using the (2) nuts provided in the mounting kit. Tighten the nuts to back the screws into the wiring box and secure the plate to the box.  
 IMPORTANT: note position of orientation arrow on mounting plate and install accordingly.
8. Replace outer casting and glass and tighten (2) screws, making sure the gasket is seated properly.

Fig.1

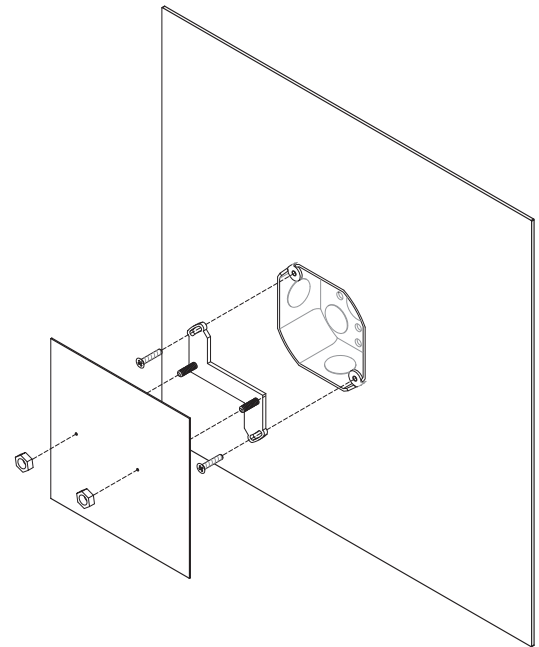

**Relamping/Maintenance**

No relamping required.

**Accessories**

Please refer to the appropriate accessory installation sheet for further instruction when applicable.

**Replacement Parts**

Description	Part No
Lens	11281311
Lens gasket	831156
LED module	LED-0261/830
LED driver	75945

**Lamp:** 4.3W LED module

In the interest of product improvement, BEGA reserves the right to make technical changes without notice.