

Tools Required:

- 2.5mm hex key
- 3mm hex key
- Phillips head screw driver medium

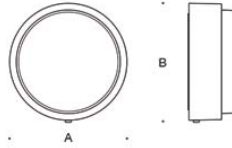

UL listed, suitable for damp locations.



Dimensions

- A: 8-1/4"
- B: 2 3/4"



Weight: 3.9 lbs.

Notice to Installer for 3535LED:

1. **BEGA luminaires may be damaged if connected to conduit systems containing water- Article 300-5G of National Electric Code requires that "Conduits or raceways through which moisture may contact energized live parts shall be sealed or plugged at either or both ends".**
2. Mounts directly to a standard octagonal 4" wiring box (by others) using BEGA mounting kit (supplied).
NOTE: Recommended that installer uses (2) screws (by others) to lock in place back housing, along with BEGA mounting kit, to wall surface for eased installation. (Fig. 2)
3. In conformance with U.L. Standards 1598, a silicone-based sealant **MUST** be used between the mounting plate edge and supporting wall.
4. LEDs are high-quality electronic components! Please avoid touching the light output opening of the LED directly during installation.

3535LED - installation:

1. Loosen 3mm set screw on luminaire outer trim ring and turn ring to the stop (ccw). Remove trim ring with glass from luminaire base.
2. Loosen (2) hex screws on LED module plate and CAREFULLY remove LED module - trying not to come into direct contact with the LED chips.
3. Feed luminaire wires through fixture base, IP nipple (provided), and center hole in mounting strap.
4. Make supply wiring and luminaire wiring connections in the octagonal wiring box:
MAIN VOLTAGE SUPPLY WIRE TO BLACK LUMINAIRE WIRE
NEUTRAL (COMMON) SUPPLY WIRE TO WHITE LUMINAIRE WIRE
WIRE GREEN GROUND WIRE TO GREEN LUMINAIRE WIRE
Dimming (if applicable):
DIMMING CONTROL WIRE (+) TO POSITIVE DRIVER DIM CONTROL WIRE
DIMMING CONTROL WIRE (-) TO NEGATIVE DRIVER DIM CONTROL WIRE
5. Attach mounting strap (provided) to wiring box using outlet box screws (by others).
6. Place a small bead of silicone around the back side of the luminaire base that will come in contact with the finished wall (exterior applications only).
7. Attach 1/4" nipple to mounting strap and place luminaire over nipple.
8. Use lockwasher and nut (provided) to secure luminaire on nipple. Tighten nut. Use (2) screws (by others) to lock back housing into place for ease of trim ring installation. Refer to Figure 3 for screw hole locations.
9. Replace the LED module carefully along with luminaire lens and trim ring. Turn trim ring to the stop (cw) and tighten outer set screw to secure.

Figure 1

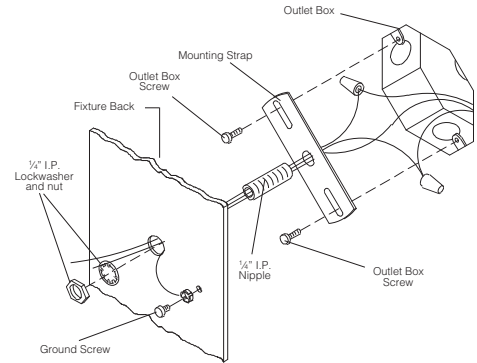
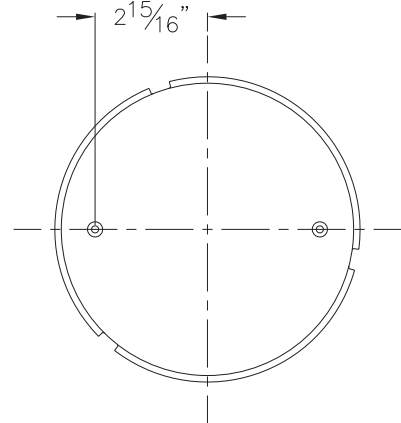

Figure 3: Secondary Wall Mount Screw Holes



Relamping/Maintenance

No relamping required.

Accessories

Please refer to the appropriate accessory installation sheet for further instruction when applicable.

Replacement Parts

Description	Part No
Lens	11286411
Lens gasket	831313
LED driver (120-277V)	75939
LED module (3000K)	LED-0338/830
LED module (4000K)	LED-0338/840

Lamp: 6W LED Module