

Tools Required:

- 3mm hex key
- 11/32" Nut driver
- Phillips medium screwdriver

CSA certified to U.S. and Canadian standards. Suitable for wet locations.

Protection Class: IP64

Weight: 3.5 lbs.

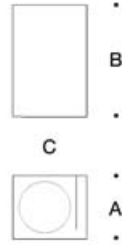

Dimensions

- A:** 4-3/8 "
- B:** 7-1/2 "
- C:** 5 "



Notice to Installer for 3580LED:

1. Mounts directly to a standard 4" octagonal recessed wiring box (by others) using adapter plate (supplied).
2. This product must be installed in accordance with the applicable installation code by a person familiar with the construction and operation of the product and the hazards involved.
3. LEDs are high-quality electronic components! Please avoid touching the light output opening of the LED directly during installation.

IMPORTANT: SILICONE RTV MUST BE APPLIED ON BOTH SIDES OF THE ADAPTOR PLATE TO ENSURE AGAINST WATER INTRUSION.

3580LED - installation:

1. Loosen (2) 3mm set screws under luminaire and remove outer casting with lens.
2. Feed luminaire wires through luminaire base and adapter plate.
3. Make supply wiring and luminaire wiring connections in the wiring box:
 CONNECT NEUTRAL SUPPLY WIRE TO WHITE FIXTURE LEAD
 CONNECT MAIN VOLTAGE (LINE) SUPPLY WIRE TO BLACK FIXTURE LEAD
 CONNECT GREEN SUPPLY WIRE TO GREEN FIXTURE LEAD
 Dimming (if applicable):
 DIMMING CONTROL WIRE (+) TO POSITIVE DRIVER DIM CONTROL WIRE
 DIMMING CONTROL WIRE (-) TO NEGATIVE DRIVER DIM CONTROL WIRE
4. Attach adapter plate to wiring box using (2) 8-32 x 1/2" screws provided.
5. Place a small bead of silicone around the back side of the luminaire base that will come in contact with the finished wall (exterior applications only).
6. Attach luminaire base to adapter plate over the mounting screws using the (2) nuts provided in the mounting kit. Tighten the nuts to back the screws into the wiring box and secure the plate to the box.
 IMPORTANT: note position of orientation arrow on mounting plate and install accordingly.
7. Replace outer casting and tighten (2) set screws, making sure the gasket is seated properly.

Figure 1

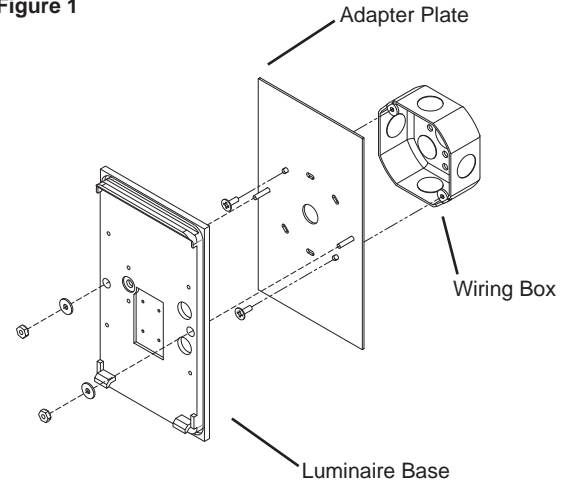

Relamping/Maintenance

No relamping required.

Accessories

Please refer to the appropriate accessory installation sheet for further instruction when applicable.

Replacement Parts

Description	Part No
Face Plate	FP3580
Housing gasket	831220
LED driver (120-277V)	75930
LED module (3000K)	LED-0124/830
LED module (4000K)	LED-0124/840

Lamp: 6.5W LED Module

In the interest of product improvement, BEGA reserves the right to make technical changes without notice.