

# ASSEMBLY INSTRUCTIONS

ITEM: 2458-36 / 2458-36(3A)

5pcs Pack Counter Height Set  
Ant Oak / Black Finish

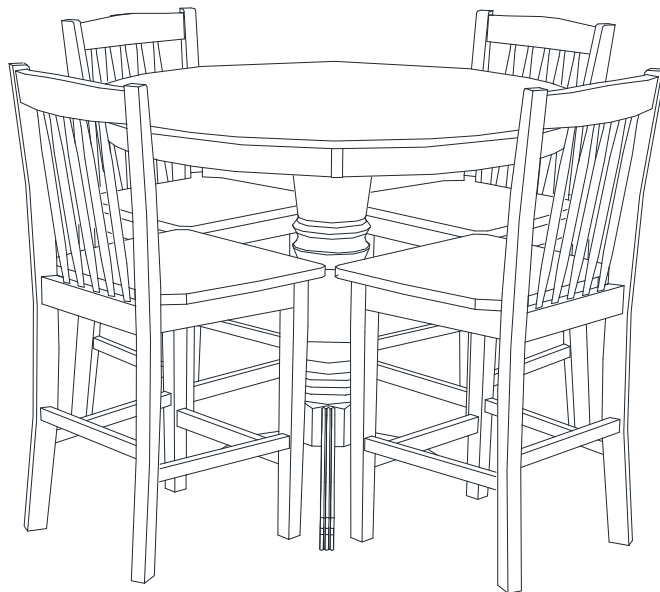







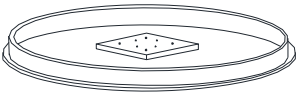
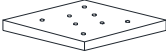

This page lists all the contents included in the box. Please take the time to identify the hardware as well as the individual components to this product. As you unpack and prepare for assembly, place the contents on a carpeted or padded area to protect them from damage.

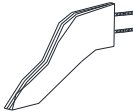
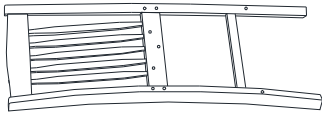
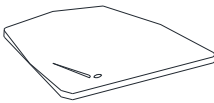
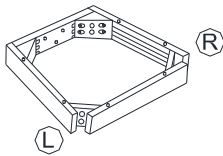
**cleaning & care** Treat surface with care. Clean surfaces with a dry or damp soft cloth. Do not use abrasive cleaners. Hardware may loosen over time. Periodically check that all connections are tight.

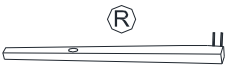



A Phillips head screwdriver is necessary for assembly.

# PART LIST

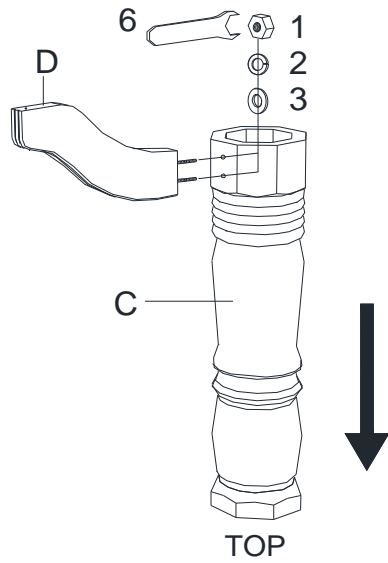
<p><b>A</b></p> 	<p><b>B</b></p> 
<p>TABLE TOP 1 PC</p>	<p>CONNECTOR PANEL 1 PC</p>
<p><b>C</b></p> 	<p><b>D</b></p> 
<p>CENTER POST 1 PC</p>	<p>LEG 4 PCS</p>
<p><b>E</b></p> 	<p><b>F</b></p> 
<p>CHAIR BACK 4 PCS</p>	<p>CHAIR SEAT 4 PCS</p>
<p><b>G</b></p> 	<p><b>H</b></p> 
<p>CHAIR SEAT FRAME 4 PCS</p>	<p>CHAIR FRONT LEFT LEG 4 PCS</p>
<p><b>I</b></p> 	<p><b>J</b></p> 
<p>CHAIR FRONT RIGHT LEG 4 PCS</p>	<p>CHAIR FRONT CROSSBAR 4 PCS</p>
<p><b>K</b></p> 	<p><b>L</b></p> 
<p>CHAIR LEFT SIDE CROSSBAR 4 PCS</p>	<p>CHAIR RIGHT SIDE CROSSBAR 4 PCS</p>

**STEP 1**



REQUIRED HARDWARE IN THIS STEP			
NO.	DESCRIPTION	SKETCH	QTY
1.	NUT		8 PCS
2.	SPRING WASHER		8 PCS
3.	FLAT WASHER		8 PCS
6.	OPEN WRENCH		1 PC

Place center post (C) upside down on a clean, smooth surface. Attach table legs (D) to the center post (C) using nuts (1), spring washers (2) and flat washers (3). Fasten nuts (1) with wrench (6).

**STEP 2**

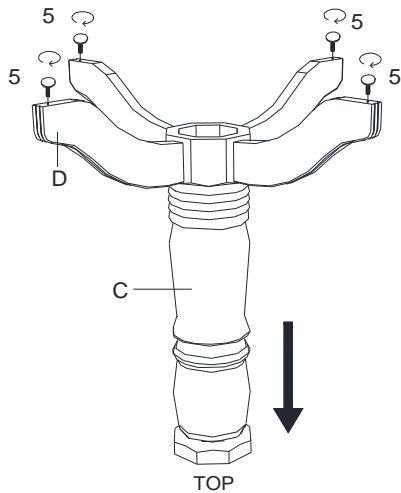



REQUIRED HARDWARE IN THIS STEP			
NO.	DESCRIPTION	SKETCH	QTY
5.	LEVELER		4 PCS

Attach levelers (5) into the pre-drilled holes on the bottom of the legs (D).

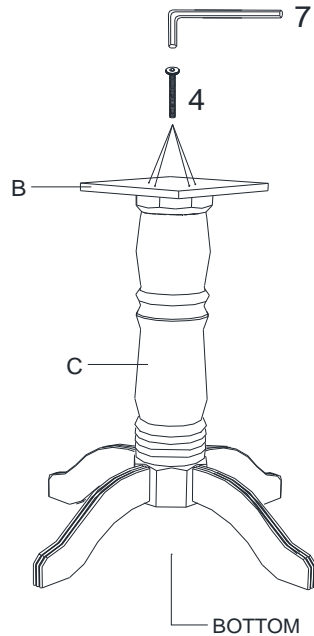
### STEP 3





REQUIRED HARDWARE IN THIS STEP			
NO.	DESCRIPTION	SKETCH	QTY
4.	LONG ALLEN BOLT		4 PCS
7.	ALLEN KEY		1 PC

Turn the assembled pedestal upright. Attach table base panel (B) to the center post (C) using long allen bolts (4). Tighten the allen bolts (4) with allen key (7).

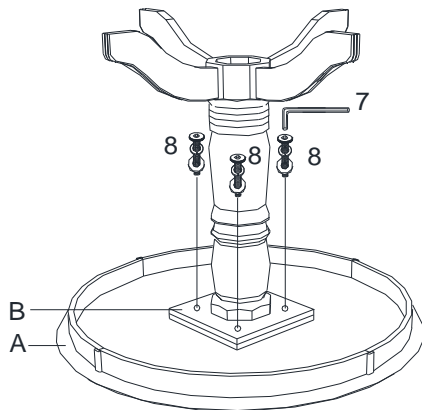
### STEP 4



REQUIRED HARDWARE IN THIS STEP			
NO.	DESCRIPTION	SKETCH	QTY
7.	ALLEN KEY		1 PC
8.	SHORT BOLT		4 PCS

Gently place the table top (A) upside down on a clean smooth surface. Attach the assembled table base to the table top (A) using short bolts (with spring and flat washers) (8). Tighten bolts (8) with allen key (7).

## STEP 5



Turn the table upright.  
The table is now ready for use

## STEP 6

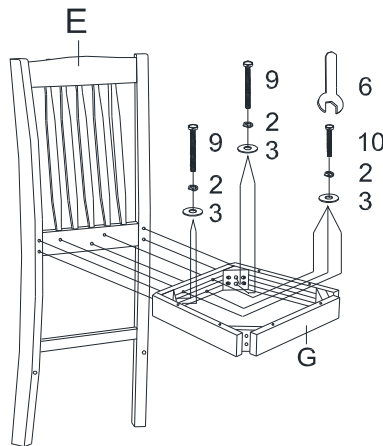

REQUIRED HARDWARE IN THIS STEP			
NO.	DESCRIPTION	SKETCH	QTY
2.	SPRING WASHER		7 PCS
3.	FLAT WASHER		7 PCS
6.	OPEN WRENCH		1 PC
9.	LONG BOLT		4 PCS
10.	SHORT BOLT		3 PCS

Attach seat frame (G) to chair back frame (E) using short bolts (10), long bolts (9), spring washers (2) and flat washers (3) as shown. Do not tighten the bolts in this step.

Note: Seat frame (G) has holes on each side. These holes are to attach the seat board (F) in the next step. Ensure that the wider end of the holes face down towards the ground.



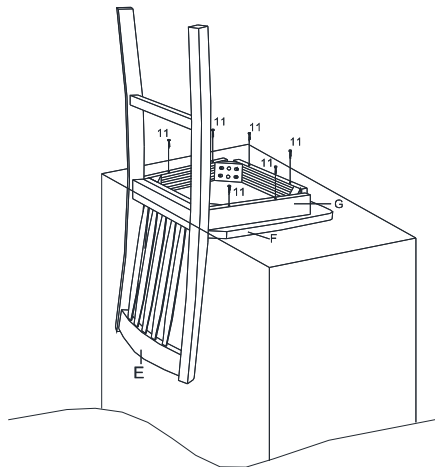

## STEP 7



REQUIRED HARDWARE IN THIS STEP			
NO.	DESCRIPTION	SKETCH	QTY
11.	WOOD SCREW		6 PCS

Place seat board (F) upside down on a clean smooth surface. Attach assembled chair frame to the seat board (F) with wood screw (11) using a Phillips head screw driver (not included).

# STEP 8

REQUIRED HARDWARE IN THIS STEP			
NO.	DESCRIPTION	SKETCH	QTY
1.	NUT		4 PCS
2.	SPRING WASHER		4 PCS
3.	FLAT WASHER		4 PCS
6.	OPEN WRENCH		1 PC
11.	WOOD SCREW		6 PCS

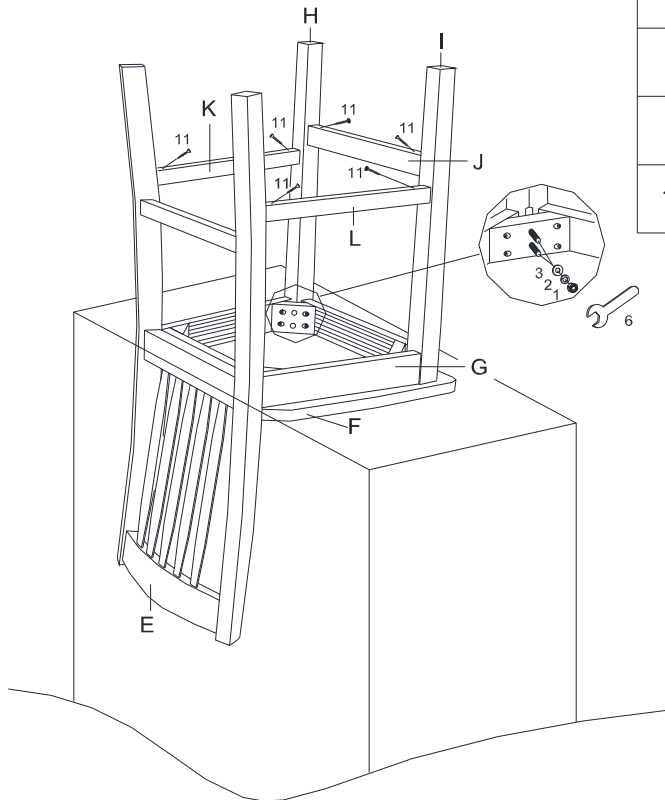

Attach chair left and right front legs (H & I) to seat frame (G) with flat washers (3), spring washers (2), and nuts (1) as shown. Do not fully tighten nuts (1). Insert chair left side crossbar and chair right side crossbar (K & L) into the front left and right chair legs (H & I) and chair back frame (E).

Note: The small holes on all the crossbars must face towards the ground (when chair in the normal use position).

Tighten all nuts previously installed with wrench (6). Secure the front crossbar (J), chair left side crossbar (K) and chair right side crossbar (L) to the chair legs using wood screws(11) and a Phillips head screw driver (not included) as shown below.

## STEP 9

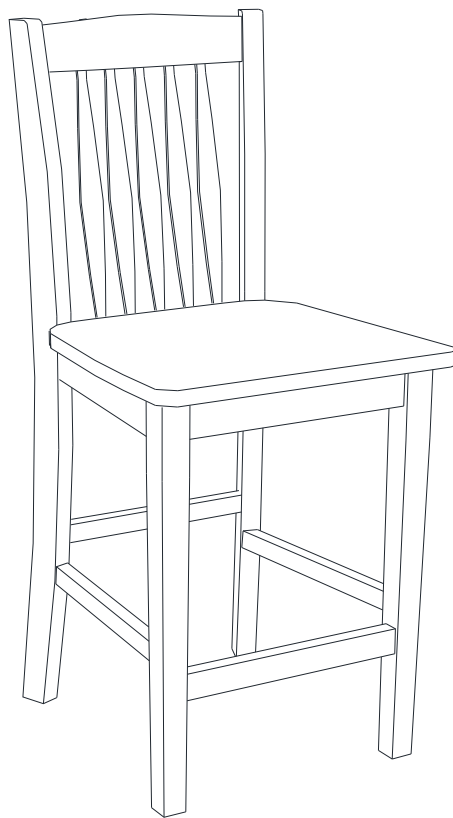

Turn the chair upright.  
The chair is now ready for use

Repeat Step 6-8 to assemble the remaining chairs.