

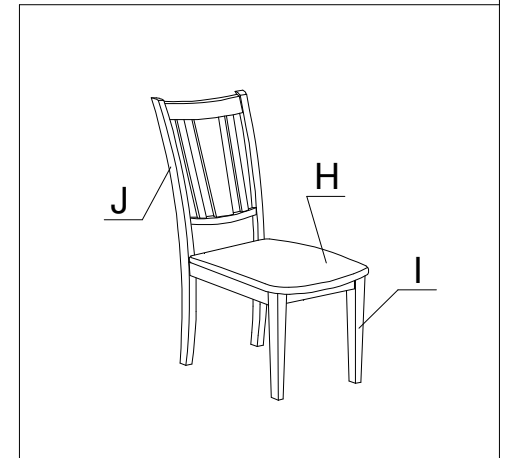

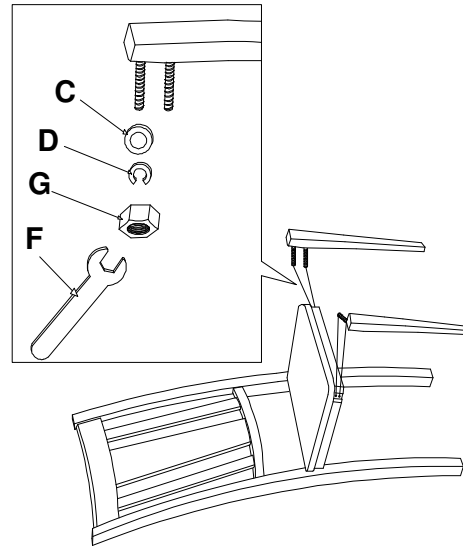

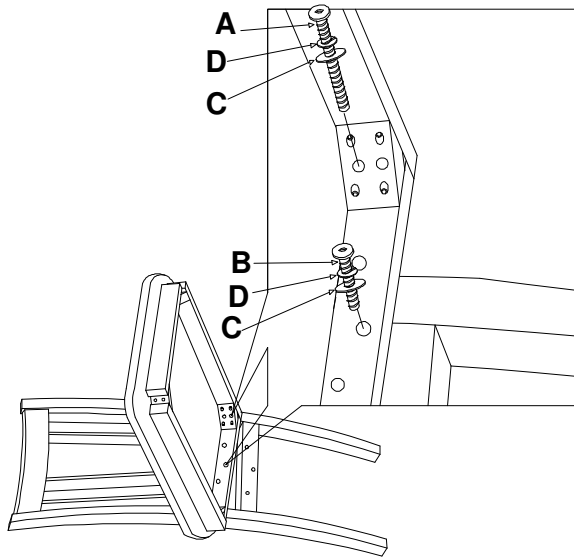



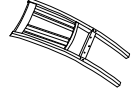

# ASSEMBLY INSTRUCTIONS



1. LAY THE CHAIR BACK FRAME (J) UP-SIDE DOWN ON A SOFT SURFACE. ATTACH CHAIR SEAT TO CHAIR BACK FRAME BY USING LONG SCREW ( A ), SPRING WASHER (D), WASHER (C), ( SIDE OF CHAIR SEAT ) SHORT SCREW (B), SPRING WASHER (D), WASHER (C) ( MIDDLE OF CHAIR SEAT ) AND SECURE BY ALLEY KEY (E). DO NOT TIGHTEN SCREWS AT THIS STEP.
2. USE NUT (G), SPRING WASHER (D), WASHER (C) TO ATTACH CHAIR SEAT (H) WITH FRONT LEG (I) AS SHOWN ON THE PICTURE. SECURE BY WRENCH (F). DO NOT TIGHTEN SCREWS AT THIS STEP.
3. PUT THE CHAIR ON UP POSITION, LEVEL THE CHAIR AND TIGHTEN ALL THE SCREWS.

(A) LONG SCREW	(B) SHORT SCREW	(C) FLAT WASHER	(D) SPRING WASHER	(E) ALLEN KEY	(F) WRENCH	(G) NUT	(H) CHAIR SEAT	(I) FRONT LEG	(J) CHAIR BACK FRAME
									
A = 4 PCS	B = 3 PCS	C = 11 PCS	D = 11 PCS	E = 1 PC	F = 1 PC	G = 4 PCS	H = 1 PC	I = 2 PCS	J = 1 PC