

ASSEMBLY INSTRUCTIONS

ITEM NO:1390A

ARM CHAIR

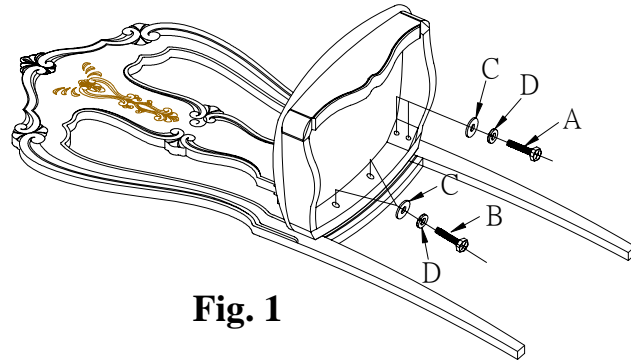
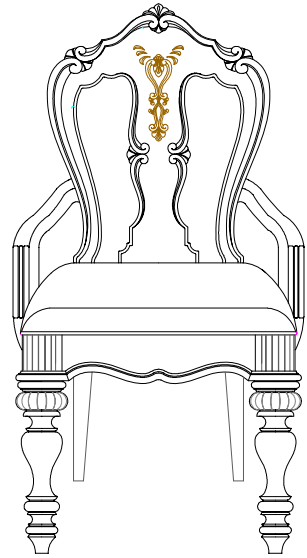

Fig. 1

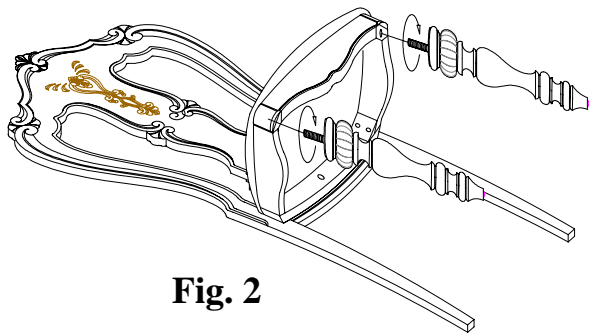

Fig. 2

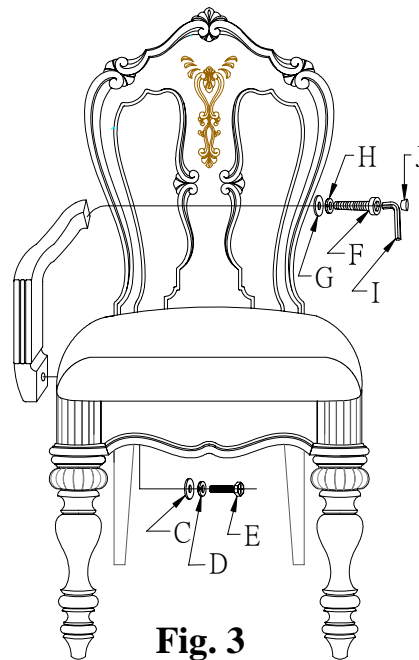

Fig. 3

LIST OF HARDWARE

NO.	SKETCH	DESC	SIZE	Q'TY
A		Bolt	5/16"x3"	4PCS
B		Bolt	5/16"x1 1/2"	2PCS
C		Flat washer	5/16"x9/10"	8PCS
D		Spring washer	5/16"	8PCS
E		Bolt	5/16"x2 1/4"	2PCS
F		Bolt	1/4"x1 1/2"	2PCS
G		Flat washer	1/4"x1/2"	2PCS
H		Spring washer	1/4"	2PCS
I		Wrench	1/6"x2"x1"	1PC
J		Wood plug		2PCS

1. Put the Chair Back down on a soft clean surface, attach the Seat Frame to the Chair Back using bolts (A) and (B), lock washer (D) and flat washer (C) as shown in Fig.1. Don't securely tighten the bolts this time;
2. Screw the Front Legs to the Chair Frame, as shown in Fig.2;
3. Attach the Chair Arms to the seat back using bolts (F), lock washer (H), flat washer (G) and wrench (I), then insert the wood plugs (J) into the hole, as shown in Fig.3. Don't securely tighten the bolts this time;
4. Place the chair on a completely level surface and adjust legs until the chair does not rock. Then securely tighten all bolts;

MADE IN CHINA