













Before you begin:

- Consider enlisting a family member or friend to help; it will make assembly easier, faster, and more fun.
- Layout all of the parts listed below.
- Save all packing materials until assembly is complete to avoid accidentally discarding smaller parts or hardware.
- You will need a Phillips head screw driver (not included)

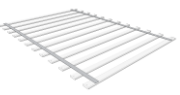
Parts List

Part	Description	Quantity
	A Metal washer (Part# 80000107)	8
	B Metal lock washer (Part# 80000108)	8
	C Machine screw (Part# 80000109)	8
	D Wood screw (Part# 80000110)	24
	E Allen wrench (Part# 80000111)	1
	F LightHeaded™ headboard (Part# 80000251 Chocolate; Part# 80000257 Black; Part# 80000263 White) ships with LightHeaded™ lighting component kit already installed	1
	G Right headboard leg (Part# 80000252 Chocolate; Part# 80000258 Black; Part# 80000264 White)	1
	H Left headboard leg (Part# 80000253 Chocolate; Part# 80000259 Black; Part# 80000265 White)	1
	I Footboard (Part# 80000254 Chocolate; Part# 80000260 Black; Part# 80000266 White)	1
	J Right side rail (Part# 80000255 Chocolate; Part# 80000261 Black; Part# 80000267 White)	1
	K Left side rail (Part# 80000256 Chocolate; Part# 80000262 Black; Part# 80000268 White)	1
	L Roll-out slats (12 pieces of wood connected with nylon straps) (Part# 80000154)	1
	M Center support rail for slats (Part# 80000333)	1
	N Support legs (short and long) for Center support rail (Part# 80000334)	6
	O LightHeaded™ TechBox contains your remote control, power cord, LightHeaded™ Lighting Instructions (for use and LightHeaded™ Image changing), and most importantly your \$20 LightHeaded™ Image gift coupon (Part# 80000152)	1

Step 1

1. Open the hinged top of your LightHeaded™ headboard, then remove the protective foam insert and attached paper and discard.
2. Your LightHeaded™ light component is pre-assembled in the headboard and ready to use. Please refer to your LightHeaded™ Lighting Assembly Instructions in the TechBox for information on how to connect power to your light, insert LightHeaded™ Images, general use, and troubleshooting if necessary.

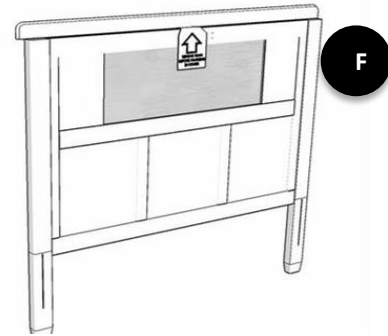

Step 2

1. With the help of your assistant, gently lay your LightHeaded™ headboard panel face down on a soft surface with the hinged top in the open position.
2. Align left leg (G) with the left side headboard post (F).
3. Align the cutout in the top of the leg with the corresponding cutout in the bottom of the headboard post. The 4 holes in the leg will align with the 4 threaded inserts in the back of your headboard panel.
4. Select 4 metal washers (A), 4 metal lock washers (B), and 4 machine screws (C). Using the Allen wrench supplied (E), tighten screws into legs through the lock washer then washer.
5. Repeat these steps for the right leg (H).

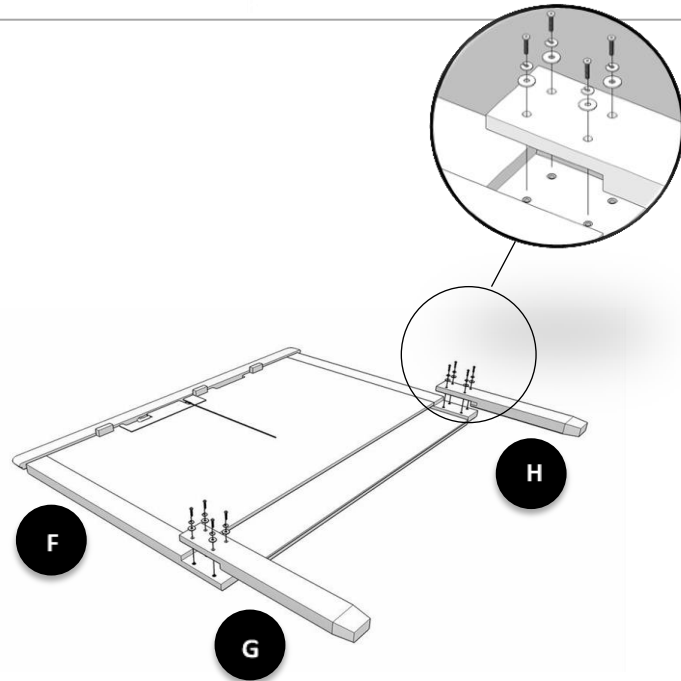

Box Spring & Mattress or **Mattress only**

It's your choice!

Your LightHeaded™ bed can be assembled to use a box spring and mattress set or a mattress only. Don't worry, you can change it at any time with a couple simple steps and no tools.

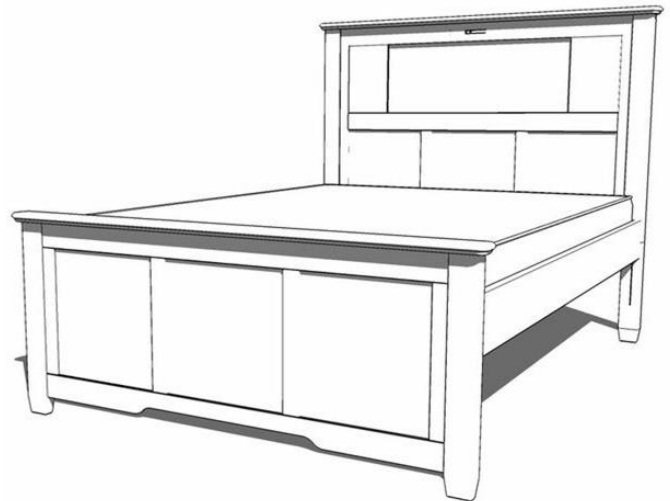
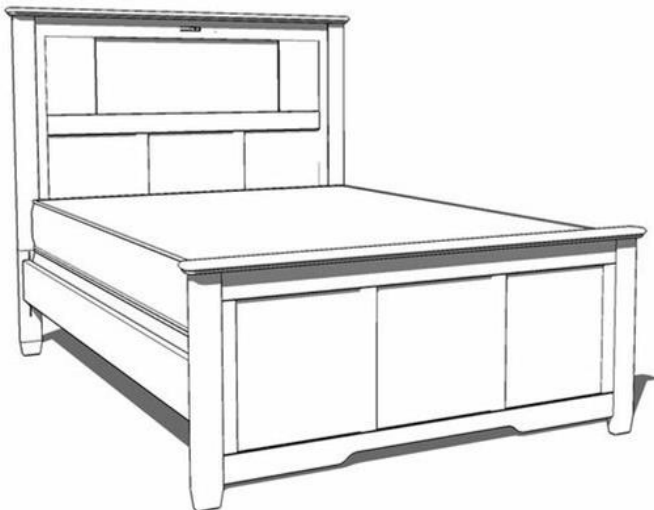

Step 3

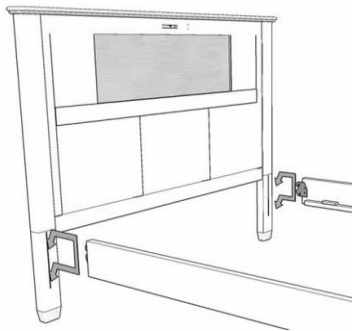

If you're using a box spring and mattress, hook your wooden side rails (J,K) onto the bottom two metal pins in the vertical slot on the headboard and footboard legs.

If you're using a mattress only, hook your wooden side rails (J,K) onto the top two metal pins in the vertical slot on the headboard and footboard legs.

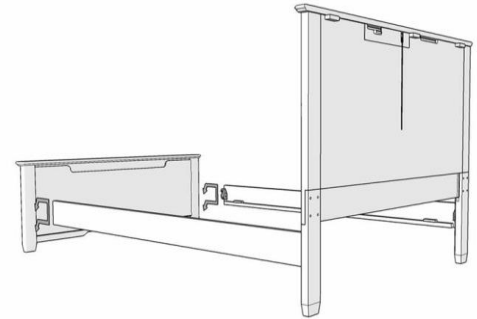

Step 4

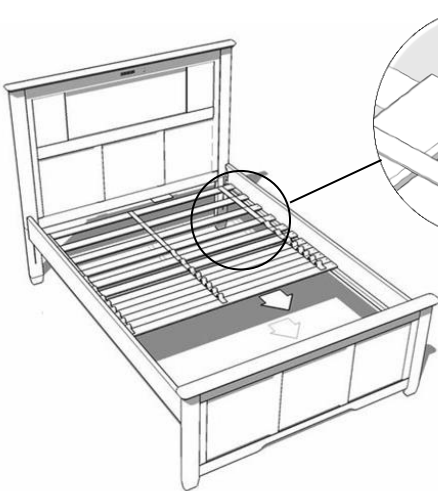

Rollout wooden slats (L) onto your side rails so that the two end slats lock into place with the wood blocks near the headboard and footboard.

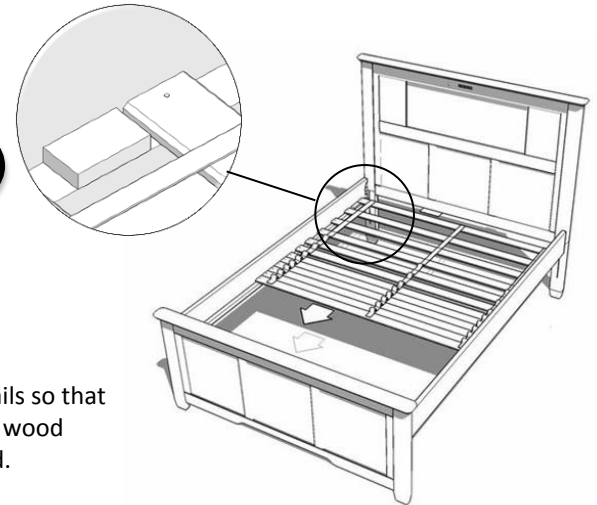

Step 5

1. If using a box spring and mattress and your side rails have been placed into the bottom two metal pins in the vertical slot on the headboard and footboard legs, choose the short support legs with cap end (N).
2. Have your assistant lift the middle of the wooden slats; align the center support rail from headboard to footboard, using the center set of pre-drilled holes. Screw 1 support leg through the center support rail (M) and into the receiver in the middle wooden slat.
3. Replace the slats and move to the foot of the bed and screw another support leg through the center support rail and into the receiver in the end wooden slat.
4. Repeat with the final support leg at the head of the bed.

1. If using a mattress only and your side rails have been placed into the top two metal pins in the vertical slot on the headboard and footboard legs, screw 1 long and 1 short support leg (N) together. Repeat to make 3 extended legs.
2. Have your assistant lift the middle of the wooden slats; align the center support rail from headboard to footboard, using the center set of pre-drilled holes. Screw 1 extended leg through the center support rail (M) and into the receiver in the middle wooden slat.
3. Replace the slats and move to the foot of the bed and screw another extended leg through the center support rail and into the receiver in the end wooden slat.
4. Repeat with final extended leg at the head of the bed.

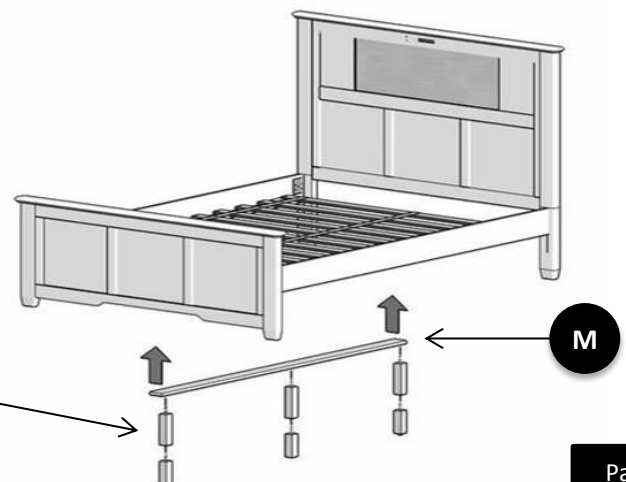
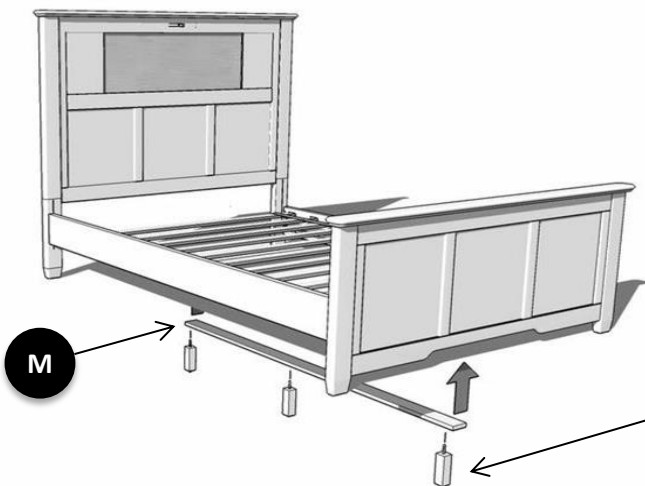

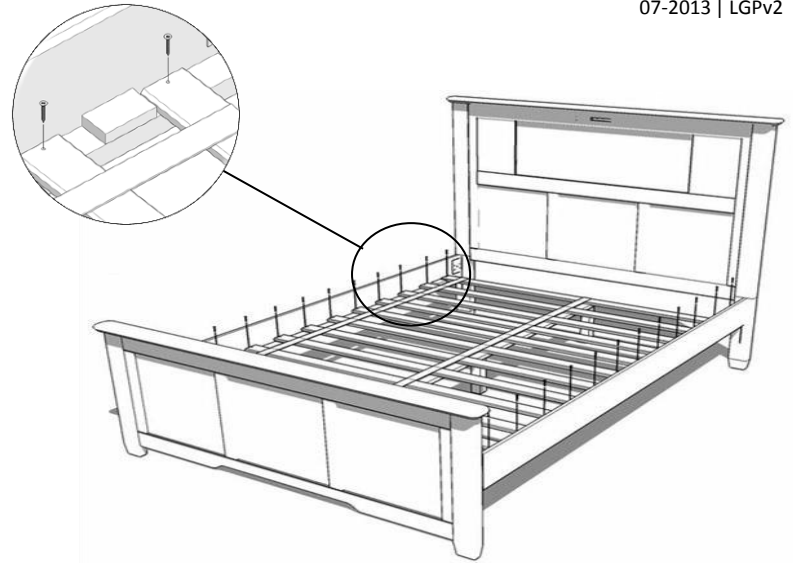

Step 6

Secure each slat into the side rails with the (D) wood screws using a Phillips head screwdriver (not included).

You have now completed the bed assembly.

Display in your headboard. Store in your footboard.

Your LightHeaded™ Bed comes with a built-in image storage on the inside of your footboard. This specially designed area allows you to organize and safely store up to 25 interchangeable LightHeaded™ Images.

Please refer to the Lighting Assembly Instructions contained in your TechBox. Locate the page titled *Using Your LightHeaded Bed* for instructions to easily remove one LightHeaded™ Image from the headboard and replace it with another.

The LightHeaded™ Image which you just removed from the headboard can now be placed into the storage area in the footboard and your LightHeaded™ Image will be ready for the next time you want to personalize your LightHeaded™ Bed.

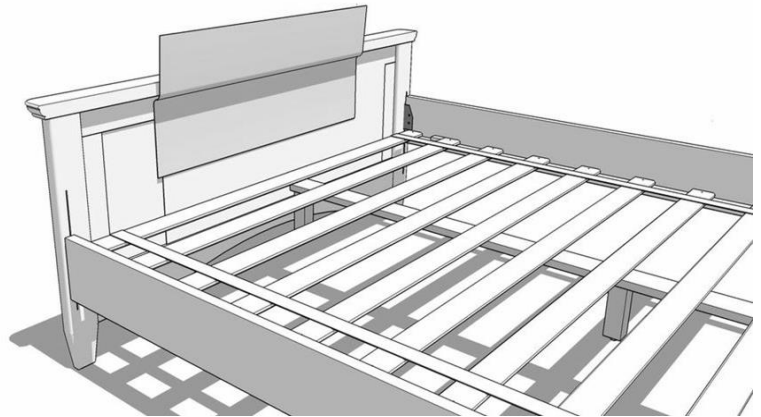

On/Off switch

On the back of your LightHeaded headboard, located just below the hinged top, is an On/Off switch which can be used to toggle the light component on or off. Please refer to your user manual in the TechBox for additional information.

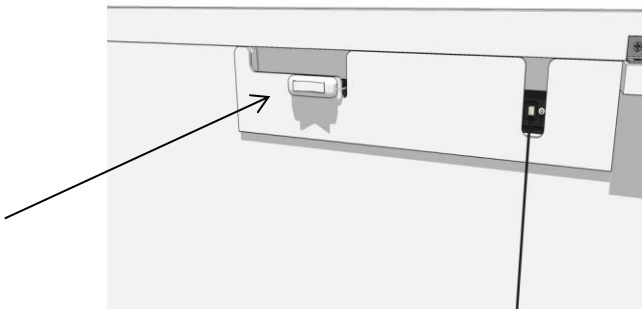

Light component positioning hole

If, after review of the Lighting Assembly Instructions contained in the TechBox, you find that your LightHeaded™ Image does not slide in and out of the headboard with little to no resistance, we've provided a 1" diameter hole located in the center of the headboard back panel. With your finger, simply apply gentle pressure to the back of the light component to reposition it, and your LightHeaded™ Image will slide effortlessly in and out of your headboard.

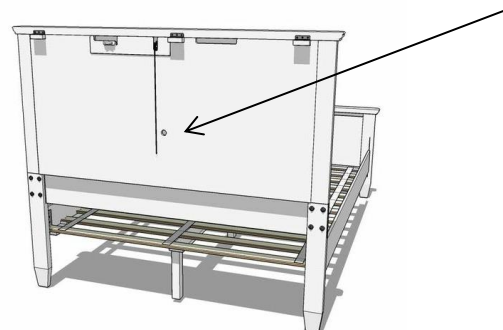

Trundle

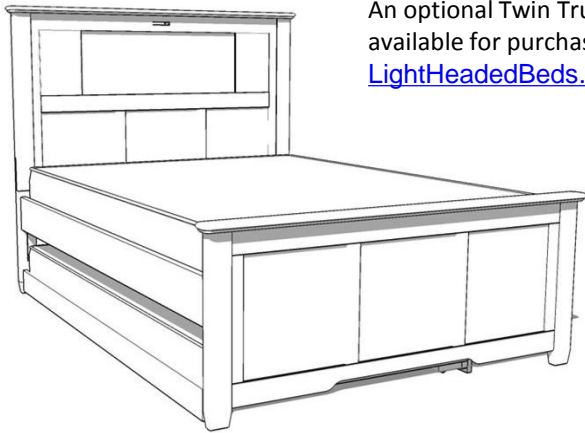

An optional Twin Trundle bed is available for purchase at LightHeadedBeds.com

Underbed storage

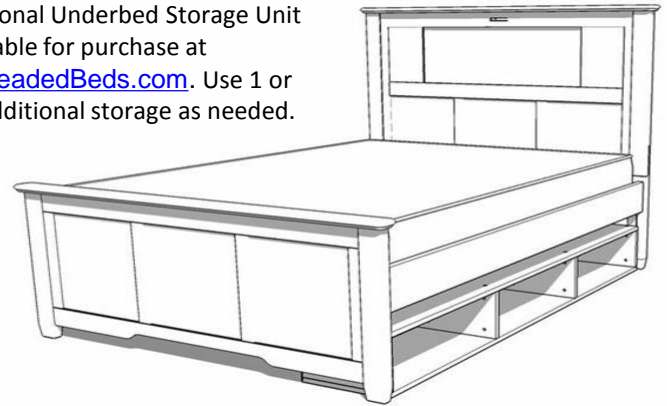

An optional Underbed Storage Unit is available for purchase at LightHeadedBeds.com. Use 1 or 2 for additional storage as needed.



Congratulations! Your LightHeaded™ bed is assembled and you are ready for the real fun.

- Hop online and surf our website LightHeadedBeds.com where you can apply your \$20 gift coupon toward your first LightHeaded™ Image and personalize your bed.
- Create your own custom images or select from our massive gallery of amazing images including your favorite Disney®, Marvel®, and other super characters.

One Year Limited Warranty

LightHeaded™ Beds warrants that for a period of one year from the date of purchase, this product will be free from defects in material and workmanship. LightHeaded™ Beds, at its option, will repair or replace the product or any component of the product found to be defective during the warranty period. Replacement will be made with a new or remanufactured product or component. If the product is no longer available, replacement may be made with a similar product of equal or greater value. This is your exclusive warranty.

This warranty is valid for the original retail purchaser from the date of initial retail purchase and is not transferable. Keep the original sales receipt. Proof of purchase is required for warranty service. LightHeaded™ Beds dealers, service centers, or retail stores selling LightHeaded™ Beds products do not have the right to alter, modify, or in any way change the terms and conditions of this warranty.

This warranty does not cover normal wear and tear of parts or damage resulting from any of the following: negligent use or misuse of the product, use on improper voltage or current, use contrary to the operating instructions, electronics disassembly, repair or alteration by anyone other than LightHeaded™ Beds authorized service representatives.

What are the Limits on LightHeaded™ Beds Liability?

LightHeaded™ Beds shall not be liable for any incidental or consequential damages caused by the breach of any express, implied, or statutory warranty or condition. Except to the extent prohibited by applicable law, any implied warranty or condition of merchantability or fitness for a particular purpose is limited in duration to the duration of the above warranty. LightHeaded™ Beds disclaims all other warranties, conditions or representations, express, implied, statutory or otherwise. LightHeaded™ Beds shall not be liable for any damages of any kind resulting from the purchase, use or misuse of, or inability to use the product including incidental, special, consequential or similar damages or loss of profits, or for any breach of contract, fundamental or otherwise, or for any claim brought against purchaser by any other party.

How to Obtain Warranty Service

We suggest you complete and return the product registration card that was included with your bed. This will help us to promptly facilitate verification of the date of your original purchase. If you have any questions regarding this warranty or would like to obtain warranty service, please call (435) 565-4490 and a friendly Customer Service Representative will assist you.

Got questions?

Our friendly LightHeaded™ Customer Service Rep can help you at 435-565-4490 or e-mail us at info@LightHeadedBeds.com. Assembly videos are available on YouTube. Thanks from the folks at www.LightHeadedBeds.com

