



TM/MC

ASSEMBLY INSTRUCTIONS INSTRUCTIONS D'ASSEMBLAGE INSTRUCCIONES DE ENSAMBLAJE

Model/ Modèle/ Modelo

-3560-3576-



WARRANTY
GARANTIE
GARANTÍA

Article/ Item/ Artículo

-043-

Media Chest
Commode média
Cómoda multimedia



- Imagine Collection



- Collection Imagine



ADULT ASSEMBLY REQUIRED

DOIT ÊTRE ASSEMBLÉ PAR UN ADULTE

DEBE SER ENSAMBLADO POR UN ADULTA

ENGLISH

N.B.: It is important to carefully read the instructions before beginning the assembly.

Identify all the parts and hardware. We recommend that you assemble the unit on a carpeted floor to avoid scratches. To facilitate assembly 2 people are required. Keep the assembly instructions for future use and for warranty purposes. It contains all pertinent information regarding replacement parts and maintenance.

FRANÇAIS

N.B. Il est important de bien lire les instructions avant de commencer l'assemblage.

Bien identifier les pièces et la quincaillerie. Il est recommandé d'assembler l'unité sur un tapis pour éviter les égratignures. Pour un assemblage facile et agréable ; 2 personnes sont requises. Gardez les instructions d'assemblage pour utilisation future et pour la garantie. Elles contiennent toutes les informations pour un remplacement de pièce ou pour l'entretien périodique.

ESPAÑOL

N.B. Lea con detenimiento las instrucciones antes de comenzar a ensamblar su mueble.

Identifique las piezas y los artículos de ferretería. Se recomienda ensamblar la unidad sobre una alfombra para evitar los rasguños. Para un ensamblaje mas facil se necesitan dos personas. Guarde el instructivo de ensamble para un futuro uso y para usos de garantía. Este instructivo contiene todas las informaciones necesarias para un sustitución de pieza o un mantenimiento periodico.

1-800-290-0465

10014239

Rev.:Ci3

23/10/2012

⚠ WARNING

Serious or fatal crushing injuries can occur from furniture tip-over. To help prevent tip-over :

- It is **important to place the safety bracket** included.
- Place heaviest items in the lowest storage space.
- Never allow children to climb or hang on drawers, doors, or shelves.
- Never open more than one drawer at a time.
- If a heavy object is placed on top or inside the furniture, consider this risk.

Use of tip-over restraints reduce, but not eliminate, the risk of tip-over.

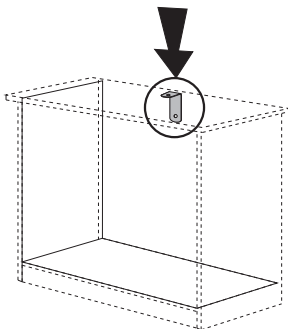

⚠ AVERTISSEMENT

Des blessures graves ou fatales peuvent résulter de basculement du meuble.

Afin de prévenir le basculement :

- Il est **important d'installer le crochet de sécurité** inclus.
- Placer les items les plus lourds dans les espaces de rangement du bas.
- Ne jamais laisser un enfant grimper sur les tiroirs, les portes et les tablettes ou s'accrocher à ceux-ci.
- Ne jamais ouvrir plus d'un tiroir à la fois.
- Si un objet lourd est placé sur l'unité ou à l'intérieur, considérez le risque de basculement.

L'utilisation de dispositif antibasculement réduit les risques de basculement, sans les éliminer totalement.

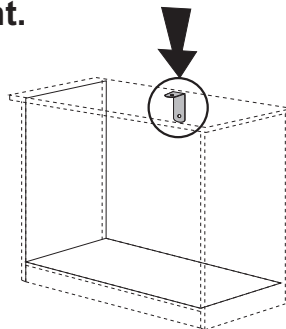

⚠ ADVERTENCIA

El vuelco del mueble puede ser causa de lesiones graves o de un aplastamiento fatal.

Para evitar el vuelco :

- Es importante instalar el gancho de seguridad.
- Ponga las cosas pesadas en los compartimentos más bajos.
- Nunca permita que un niño se suba o se cuelgue en cajones, puertas o estantes.
- Nunca abra más de un cajón a la vez.
- Si un objeto pesado está colocado dentro o sobre el mueble, considere el riesgo de que se puede voltear.

El uso de sujetadores para evitar el vuelco sólo puede disminuir el riesgo de un vuelco, pero no lo elimina.

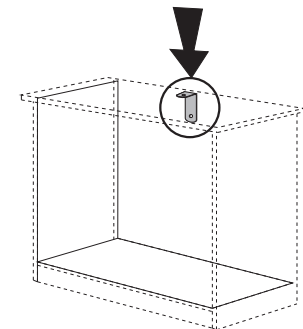

-Safety bracket installation
-Installation de l'équerre de sécurité
-Instalacion del escuadra de seguridad

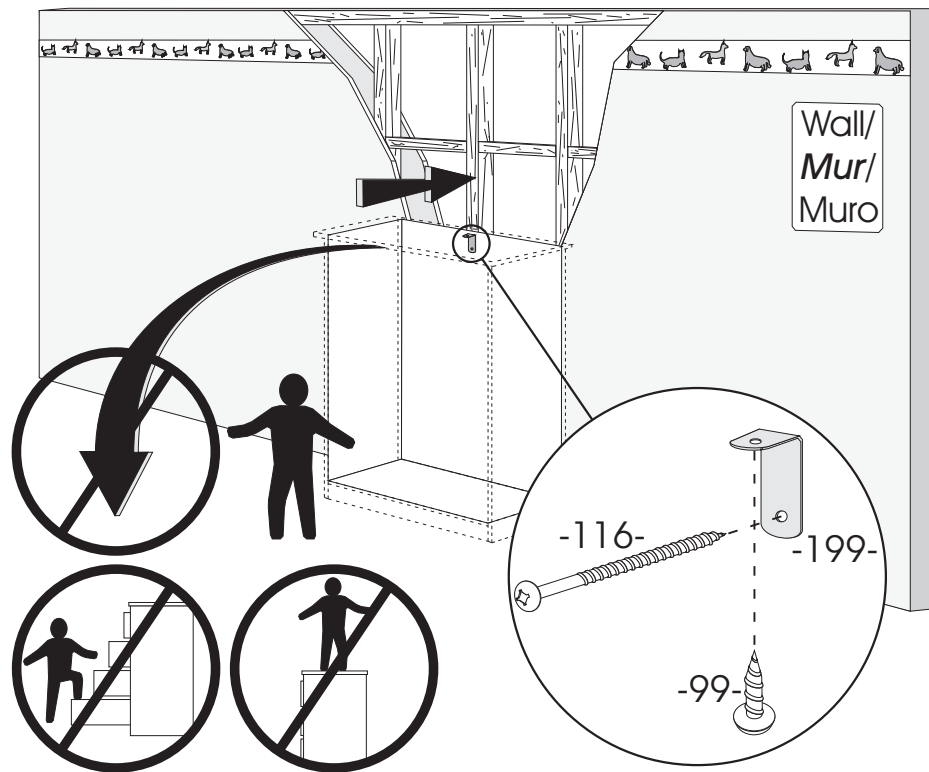

- TO PREVENT THE UNIT FALLING ON CHILDREN
Locate a stud in the wall behind the unit. Screw -199- under the top with -99-. And through the back of the unit with -116- into the solid part of the wall.
- If the safety bracket is not in the box, please contact the consumers service in order to obtain another one before using the furniture.

- **POUR EMPÊCHER LE MEUBLE DE BASCULER SUR LES ENFANTS**
Localiser un colombage, dans la largeur du meuble.
Visser -199- sous le dessus du meuble avec -99-.
Et à travers le dos du meuble avec -116-, dans la partie solide du mur.
- Si le crochet est absent, veuillez contacter notre service aux consommateurs pour obtenir cette pièce avant l'utilisation.

- POR IMPEDIR EL MUEBLE QUE VOLCAR SOBRE LOS NIÑOS.
Localizar uno entramado, en la anchura del mueble.
Atornillar -199- debajo la pieza del encima con -99-.
Y a través del dorso del mueble con -116-, en la parte solida del muro.
- Si falta el gancho de seguridad, debería que ponerse en contacto con nuestro servicio al cliente para obtener un gancho antes de utilizar el mueble.

CUSTOMERS SERVICE/ SERVICE À LA CLIENTÈLE/ SERVICIO A LA CLIENTELA

If you have any difficulty assembling this unit, or to order replacement parts, do not hesitate to contact us.

Do not return any parts to the store, find the number(s) of the part(s) in the "Exploded view" or the "Hardware list", and CALL our customer service !



Si vous éprouvez des difficultés à assembler les pièces, ou pour commander des pièces de remplacement, n'hésitez pas à communiquer avec nous.

Ne rapporter aucune pièce au magasin, repérez le(s) numéro(s) de(s) pièce(s) en question, dans la "Vue explosée" ou "la Liste de quincaillerie", et TÉLÉPHONEZ à notre service à la clientèle.

Si el Ensamblaje del mueble presenta ciertas dificultades, o para enviarle unas piezas de reemplazo, no dude en llamarnos.

No traiga ninguna pieza al comercio.

Identifique el o los número(s) de la(s) pieza(s) en cuestión en "la Lista de ferretería" o la "visión de conjunto" y LLAME a nuestro servicio a la clientela.

 **1-800-290-0465** 

N.B.: Discard two end packing parts.

These are for protection during shipping.

N.B.: *Les pièces aux extrémités de la boîte ne vous sont d'aucune utilité pour l'assemblage du meuble. Ce ne sont que des protecteurs.*

N.B.: Las piezas en las extremidades de la caja son inútiles para ensamblar el mueble. Sirven únicamente para protegerlo.

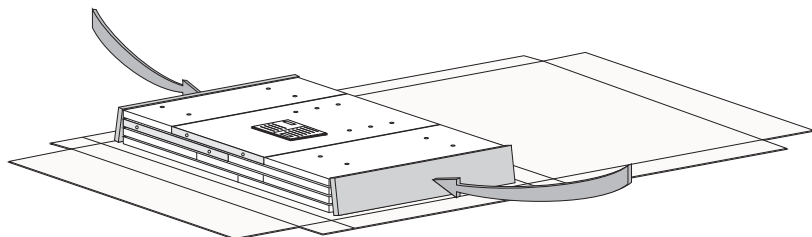

MAINTENANCE TIPS/CONSEILS D'ENTRETIEN/CONSEJOS DE MANUTENIMIENTO

- Never let liquids or damp cloths sit on this furniture.
- *Ne jamais laisser de liquide ou linge humide sur le meuble.*
- Nunca deje un líquido o un trapo húmedo sobre el mueble.



- Never use ammonia-based cleaning products, as they will damage the finish.
- *Ne jamais utiliser de nettoyeur à base d'ammoniaque, cela va endommager le fini.*
- Nunca utilice un producto de limpieza a base de amoníaco, esto dañará el acabado.



- To avoid dulling of the finish, do not place furniture in direct sunlight.
- *Ne pas placer le meuble directement au soleil pour prévenir le ternissement.*
- No exponga el mueble directamente al sol para prevenir empañamiento.

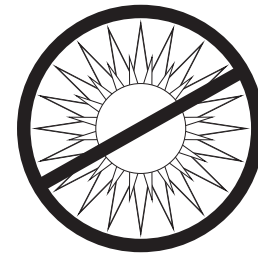

- Do not put plastic or rubber rings under appliances. Use cloth or felt protectors.
- *Évitez de déposer des appareils avec des rondelles de plastique ou de caoutchouc. Utilisez un protecteur en tissu ou en feutre.*
- Evite apoyar aparatos con redondeles de plástico o de goma. Utilizar un protector de tela o de fieltro.

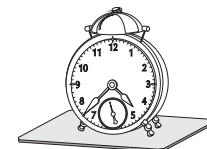

- To clean, use a soft or slightly damp cloth, then wipe with a clean, dry cloth.
- *Pour nettoyer, utilisez un linge doux ou légèrement humecté.*
- Para limpiar, utilice un trapo suave o ligeramente humedecido. Seque luego con un trapo limpio y seco.

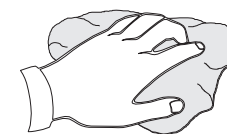

-EXPLODED VIEW (Piece numbers for reference)FACING THE UNIT
 -VUE EXPLOSÉE (Numéros des pièces pour références)FACE AU MEUBLE
 -VISIÓN DE CONJUNTO (Número de las piezas para referencia)FRETE AL MUEBLE

35XX-043

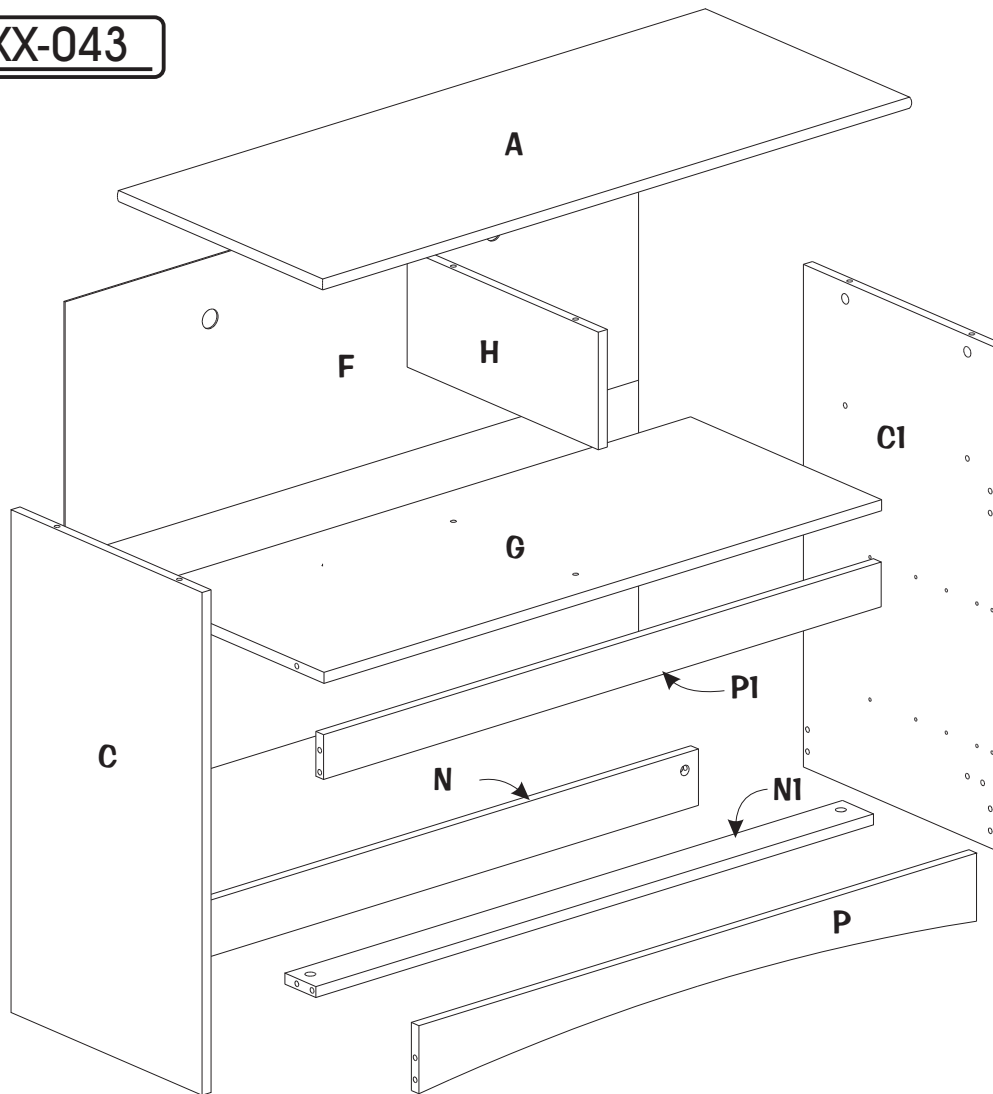





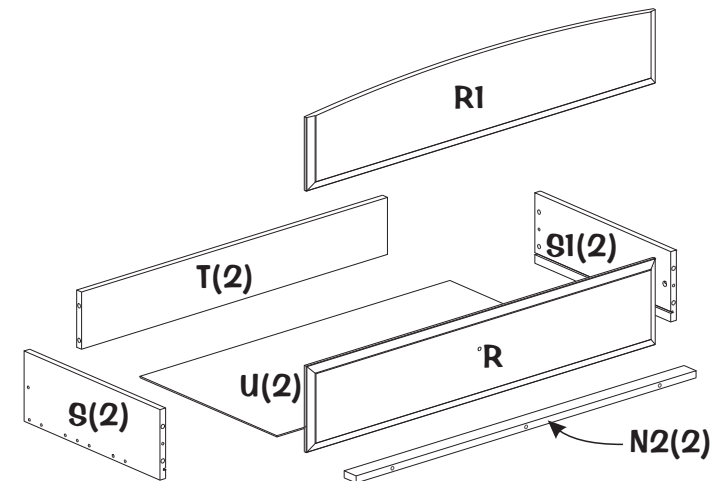





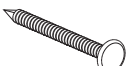
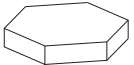
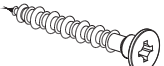
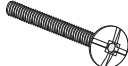
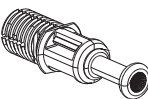

LEFT SIDE
 CÔTÉ GAUCHE
 LADO IZQUIERDO

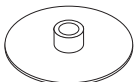
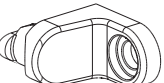
RIGHT SIDE
 CÔTÉ DROIT
 LADO DERECHO

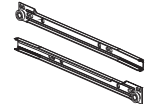
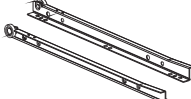

- All parts, except for F and U(2) are marked out or labelled on one side.
- *Toutes les pièces, sauf F et U(2) sont repérées par marquage sur un des côtés, ou par étiquetage sur une des faces.*
- Todas las piezas, a excepción de F y U(2) están identificadas con una marca en los lados o con etiquetas en una de las caras.

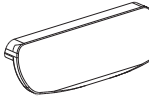
CODE CODE CODIGO	QTY QTE CANTIDAD	HARDWARE DESCRIPTION DESCRIPTION DE LA QUINCAILLERIE DESCRIPCION DE LA FERRETERÍA	
6	4	FELT FEUTRE FIELTRO	
90	22	3/4" COMMON NAIL CLOU À TÊTE 3/4" CLAVO DE 3/4" CON CABEZA	
92	16	10 MM EURO SCREW VIS EURO 10MM TORNILLO EURO 10 MM	
99	4	9/16" ROUND HEAD SCREW VIS 9/16" TÊTE RONDE TORNILLO 9/16" CABEZA REDONDA	
106	12	CRENELATED NAIL CLOU CRÉNELÉ CLAVO DENTADO	
109	4	BUMPER COUSSINET COJINETE	
111	8	1 1/4" FLAT HEAD SCREW VIS 1 1/4" TÊTE PLATE TORNILLO 1 1/4" CABEZA PLANA	
128	8	3/4" HANDLE SCREW VIS 3/4" POUR POIGNÉE TORNILLO 3/4" PARA MANIJA	
144	16	QUICK FIT DOWEL GOUJON À ENFONCER CLAVIJA DE FIJACIÓN	
158	16	15X12MM CAM KLIX ÉCROU KLIX 15 X 12MM TUERCA KLIX 15X12 MM	
171	11	PLASTIC CAP CAPUCHON DE PLASTIQUE CAPUCHÓN DE PLÁSTICO	
184	8	FIXING BRACKET ÉQUERRE DE FIXATION ESCUADRA DE FIJACIÓN	

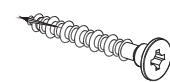
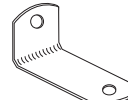
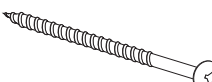
CODE CODE CODIGO	QTY QTE CANTIDAD	HARDWARE DESCRIPTION DESCRIPTION DE LA QUINCAILLERIE DESCRIPCION DE LA FERRETERÍA	
207	Pairs 2 Paires Pares	METAL DRAWER SLIDE (R/L) 350 MM COULISSE DE MÉTAL (D/G) 350 MM CORREDERA DE MÉTAL (I/D) 350 MM	
208	Pairs 2 Paires Pares	METAL DRAWER SLIDE (R/L) 350 MM COULISSE DE MÉTAL (D/G) 350 MM CORREDERA DE MÉTAL (I/D) 350 MM	
229	4	PLASTIC DOWEL GOUJON DE PLASTIQUE TARUGO DE PLASTICO	
231	15	PLASTIC DOWEL GOUJON DE PLASTIQUE TARUGO DE PLÁSTICO	
242	8	PLASTIC DOWEL GOUJON DE PLASTIQUE TARUGO DE PLASTICO	
278	8	13 MM EURO SCREW VIS EURO 13 MM TORNILLO EURO 13 MM	
358	4	-3576-	
475		-3560-	
414	6	29mm FLAT HEAD SCREW VIS 29mm TÊTE PLATE TORNILLO 29mm CABEZA PLANA	
199	1	SECURITY BRACKET ÉQUERRE DE SÉCURITÉ ESCUARDA DE SEGURIDAD	
116	1	2 1/2" ROUND HEAD SCREW VIS 2 1/2" TÊTE RONDE TORNILLO 2 1/2" CABEZA REDONDA	

* TOOLS REQUIRED/OUTILS REQUIS/HERRAMIENTAS REQUERIDOS:

- 2 PEOPLES/2 PERSONNES/2 PERSONAS

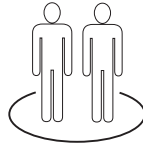

- HAMMER/MARTEAU/MARTILLO

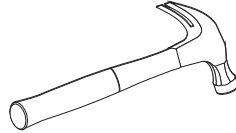

- PHILLIPS/ÉTOILE/ESTRELLA

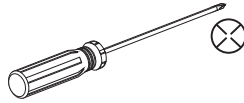

OR/OU/O

- ROBERTSON #1 and #2
- CARRÉ #1 et #2
- CUADRADO #1 y #2

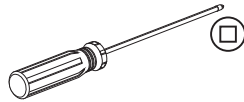

1

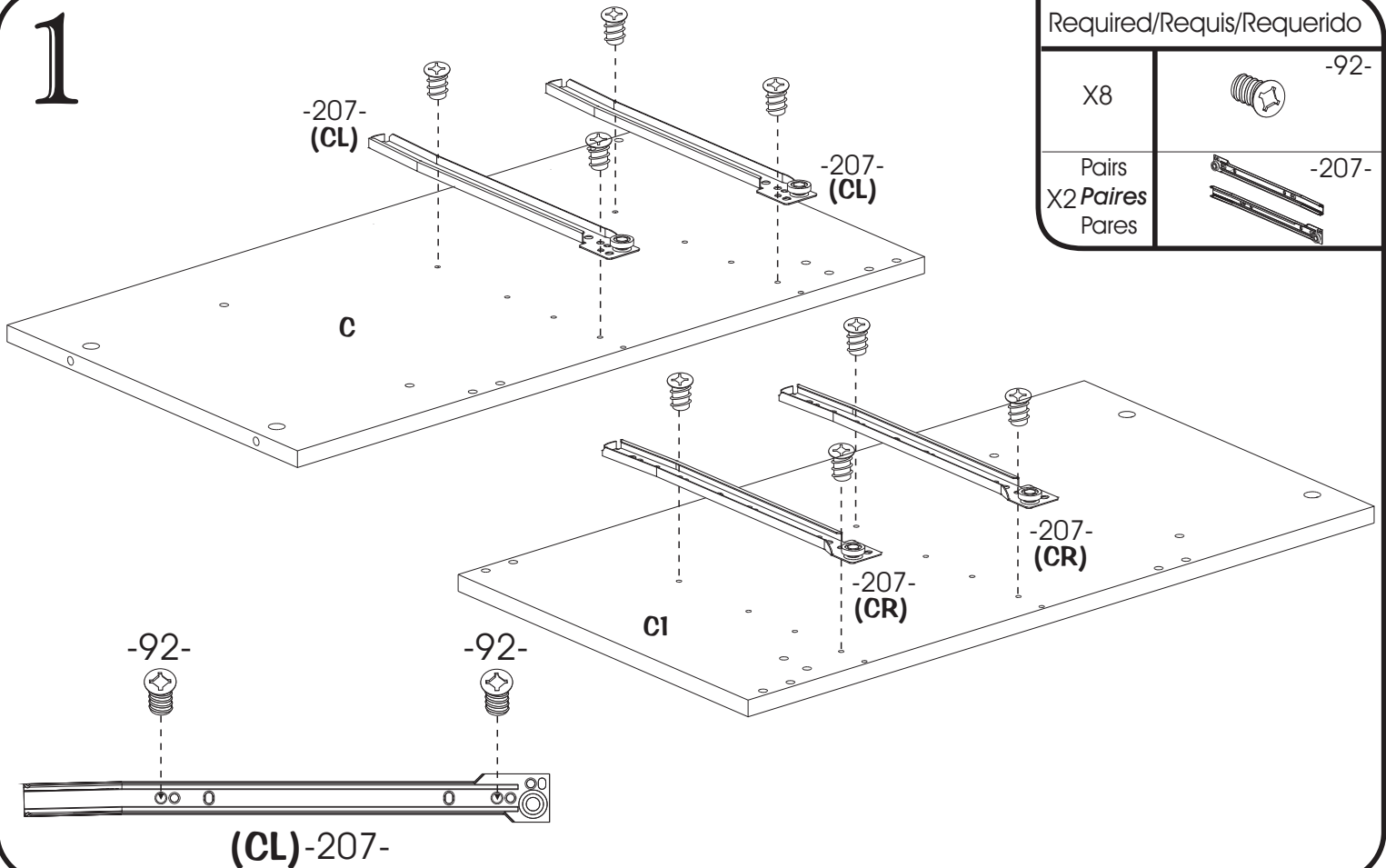

2

Required/Requis/Requerido

X4

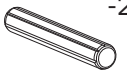

-229-

X8

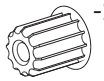

-242-

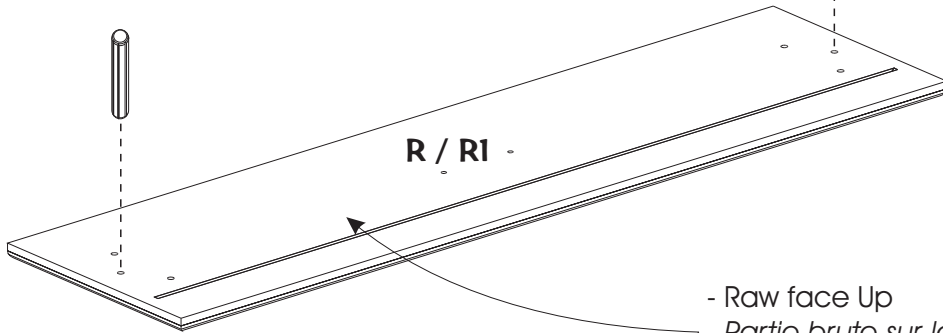

R / RI

- Raw face Up
- *Partie brute sur le dessus*
- Lado bruto encima

2x Drawers
Tiroirs
Cajones

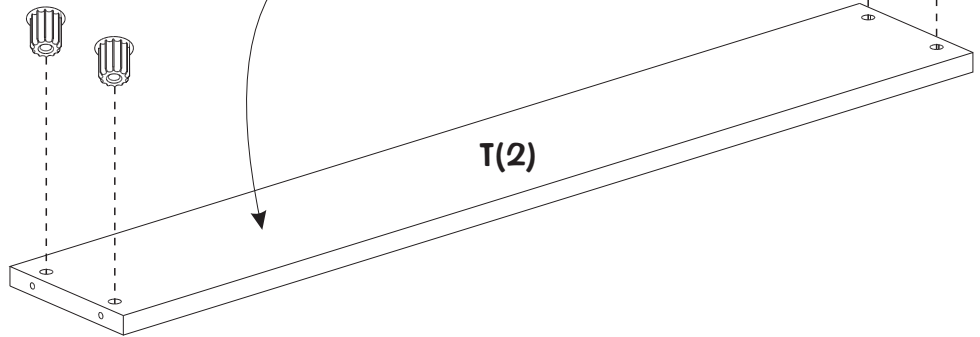

T(2)

3

Required/Requis/Requerido

X8



-92-

Pairs
X2 Paires
Paras

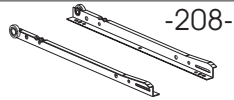

-208-

2x Drawers
Tiroirs
Cajones

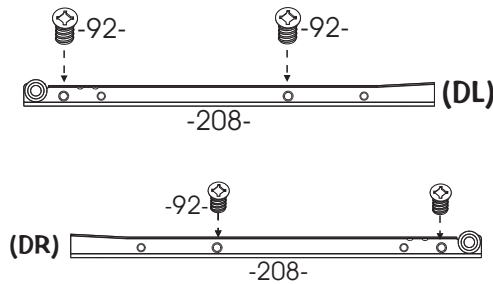

(DL)

(DR)

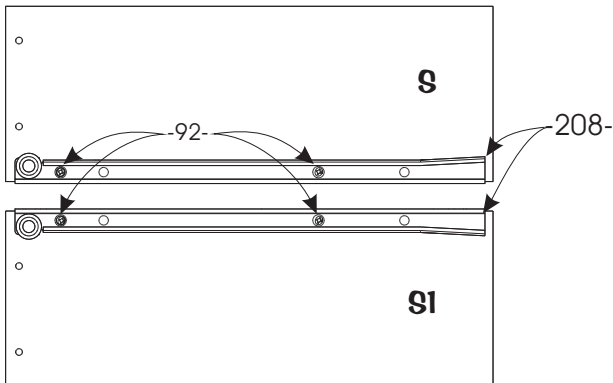

S

SI

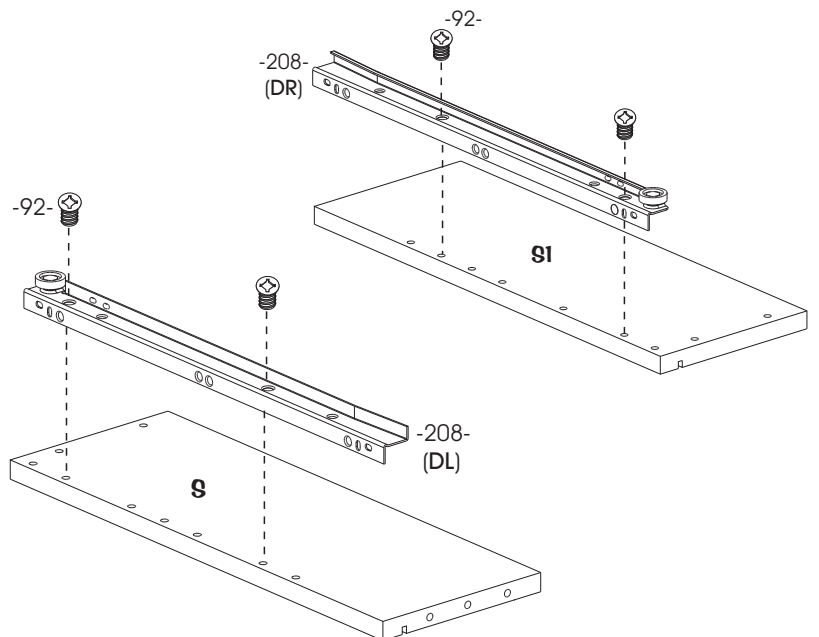

-208- (DR)

SI

-208- (DL)

S

4

Required/Requis/Requerido

X8

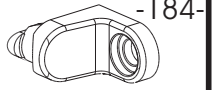

-184-

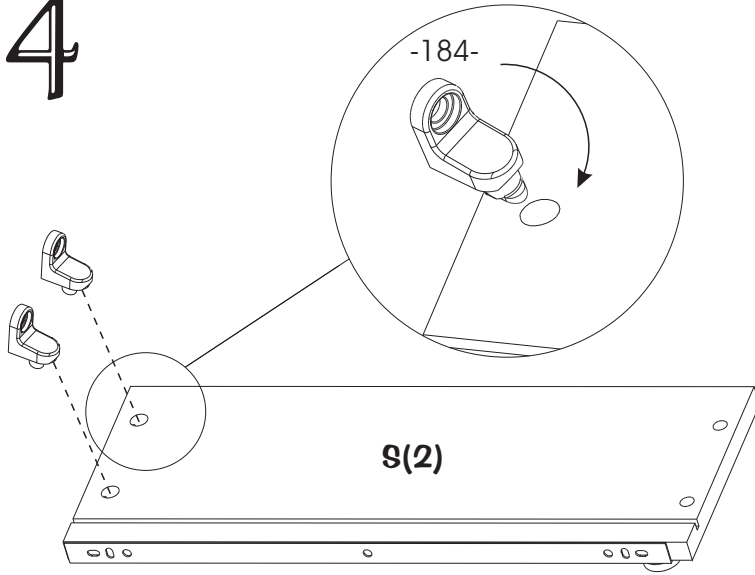

2x Drawers
Tiroirs
Cajones

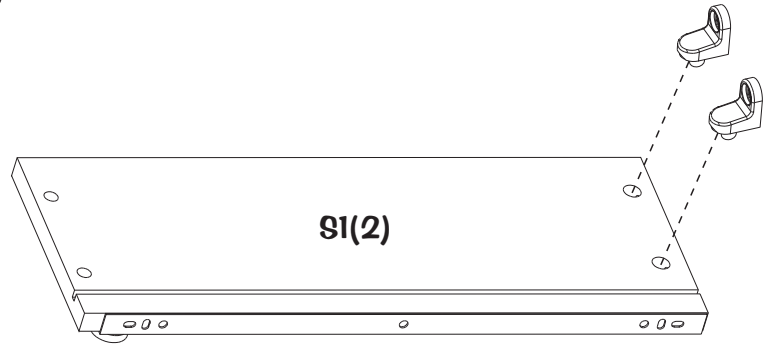

5

Required/Requis/Requerido

X6

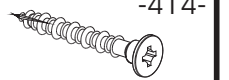

-414-

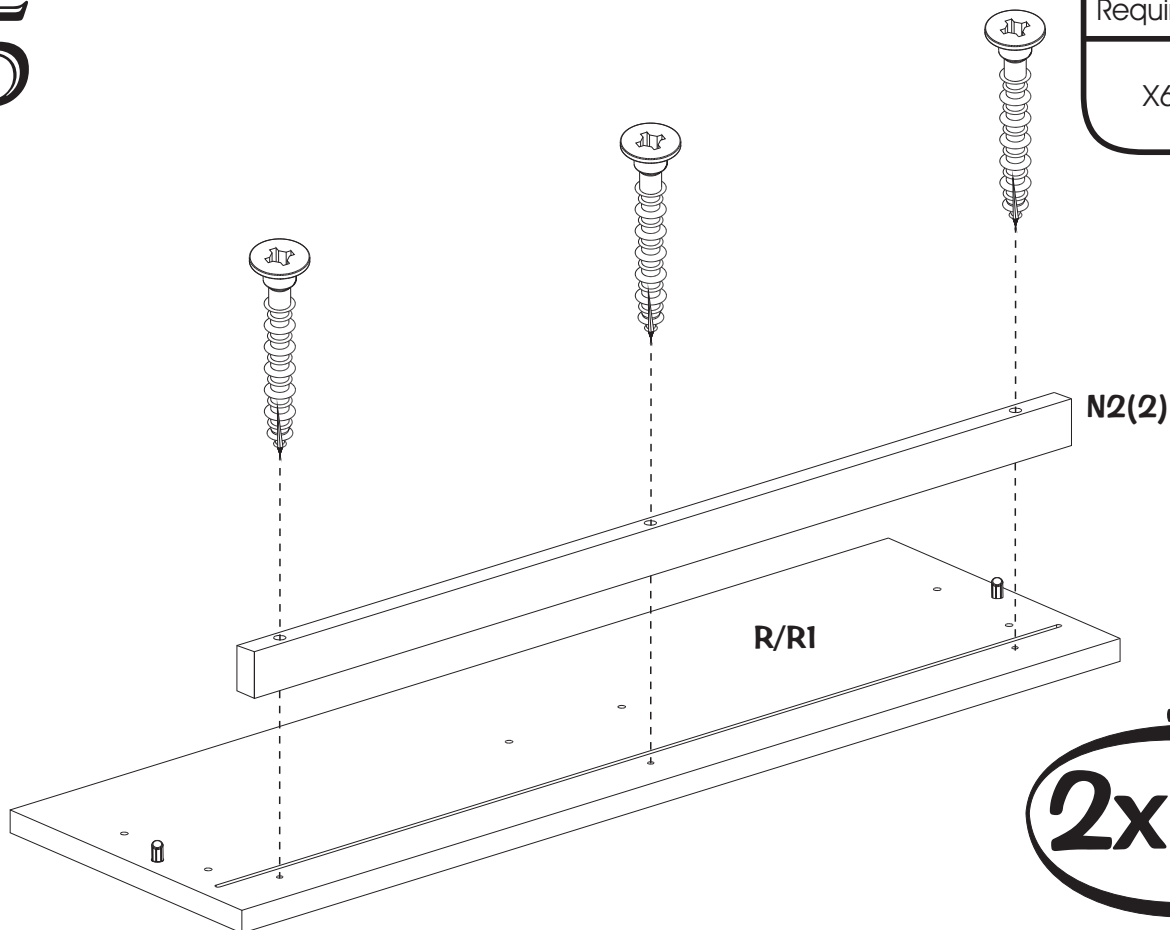

2x Drawers
Tiroirs
Cajones

6

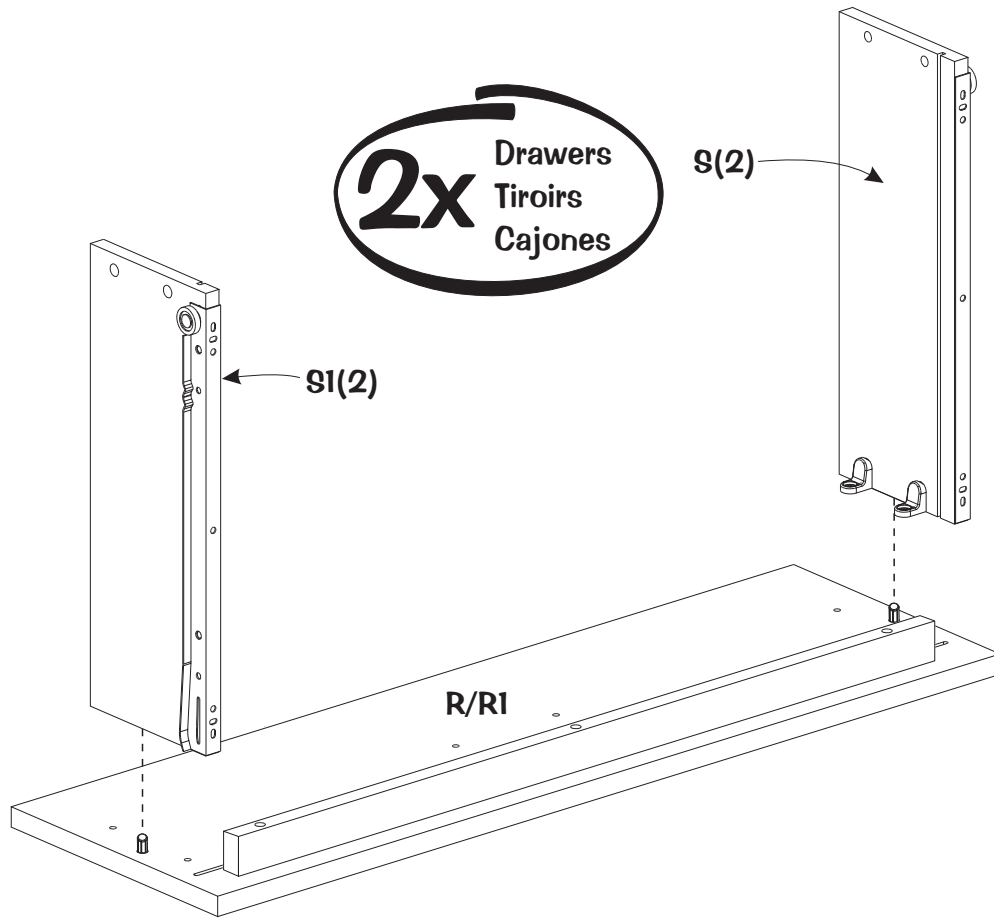

7

Required/Requis/Requerido

X8

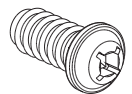

-278-

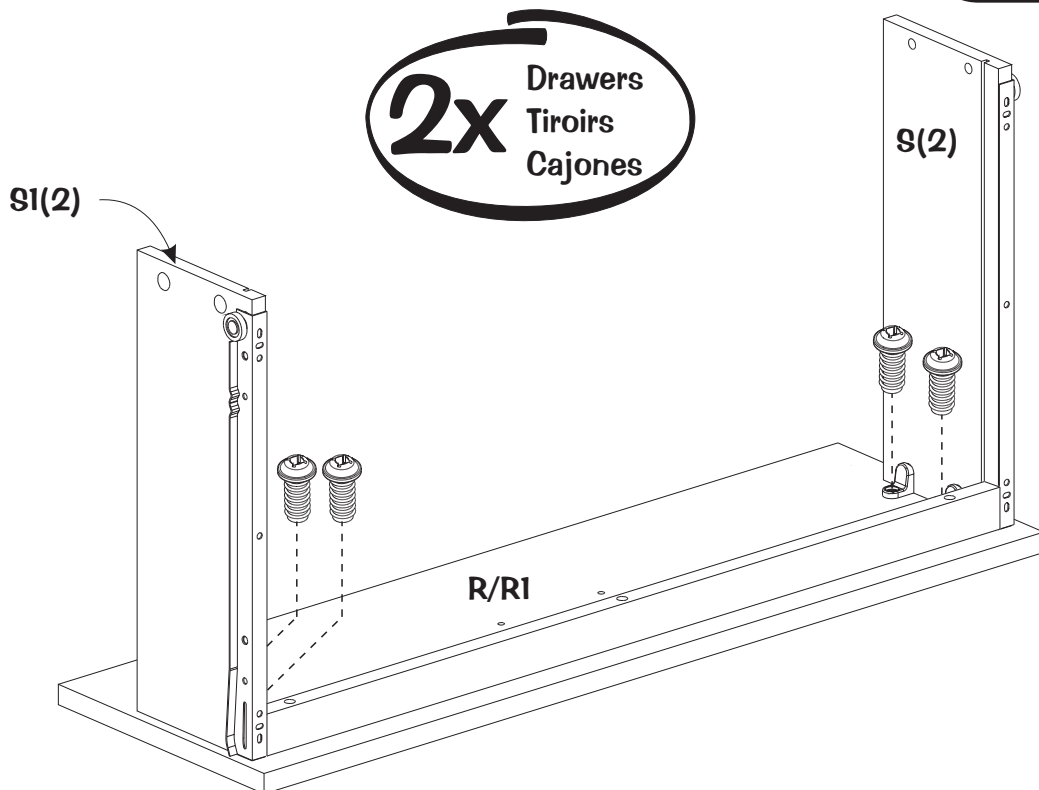

8

2x Drawers
Tiroirs
Cajones

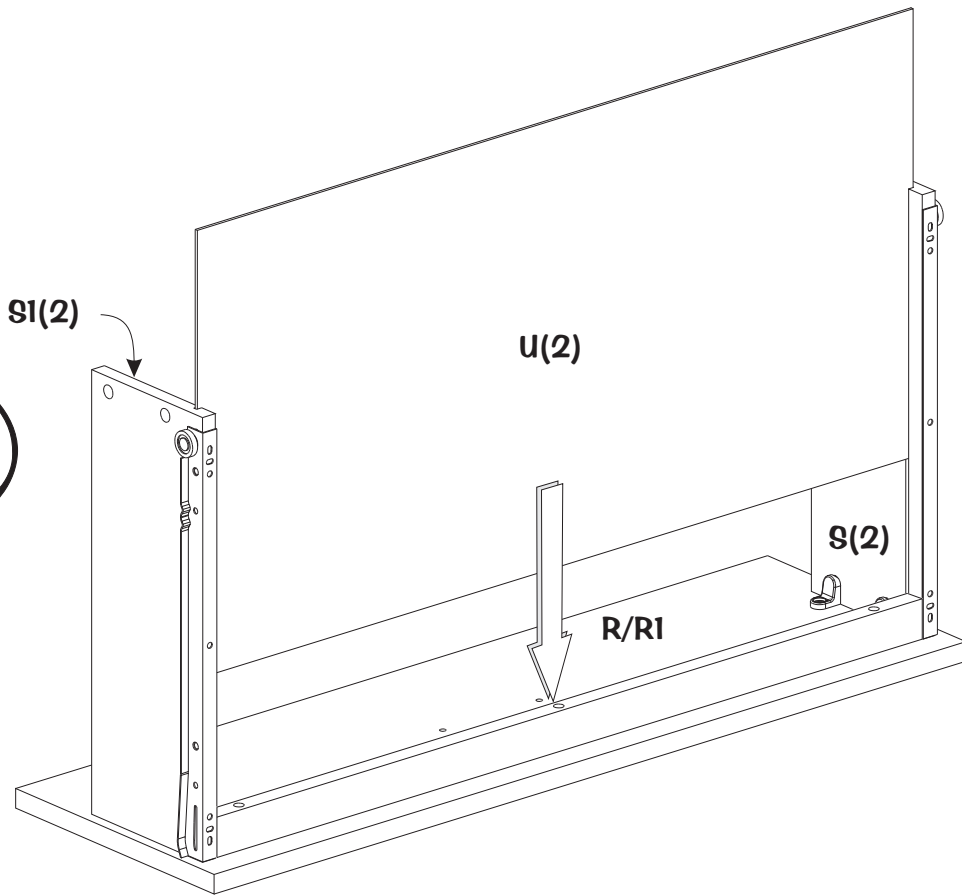

9

With care
Avec précaution
Con preconción

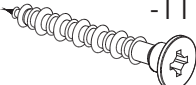
Required/Requis/Requerido	
X8	 -111-

2x Drawers
Tiroirs
Cajones

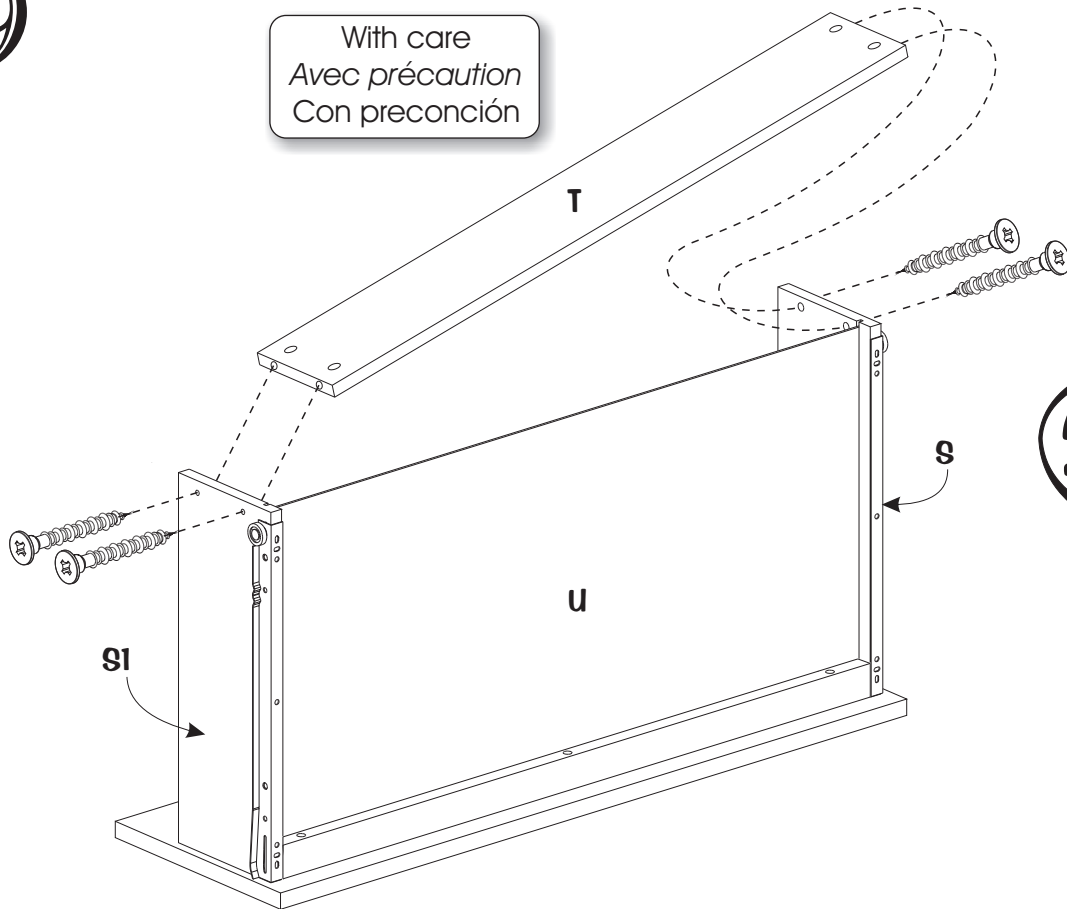

10

Required/Requis/Requerido

X12

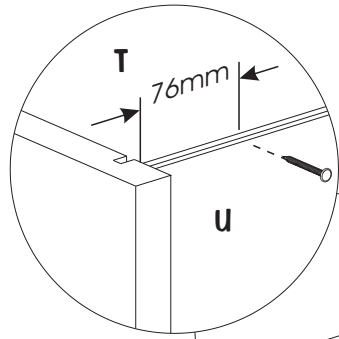
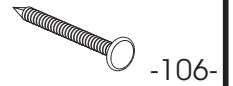

2x Drawers
Tiroirs
Cajones

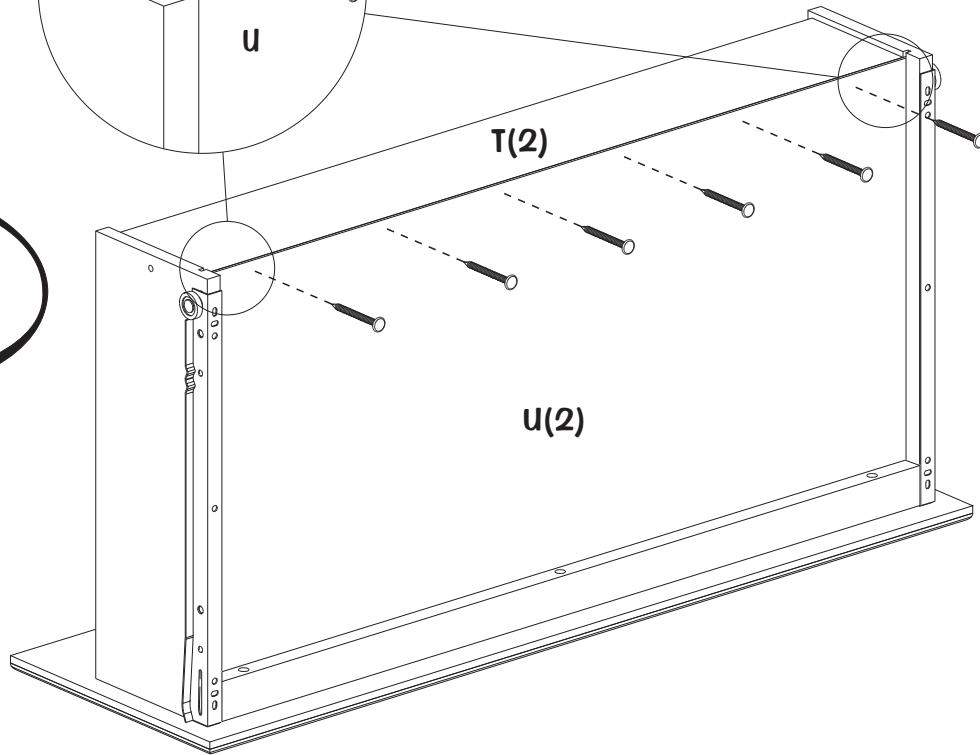

11

Required/Requis/Requerido

X8

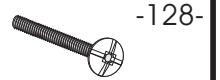

2x Drawers
Tiroirs
Cajones

X4 **-3576-** -358-

X4 **-3560-** -475-

X4 -109-

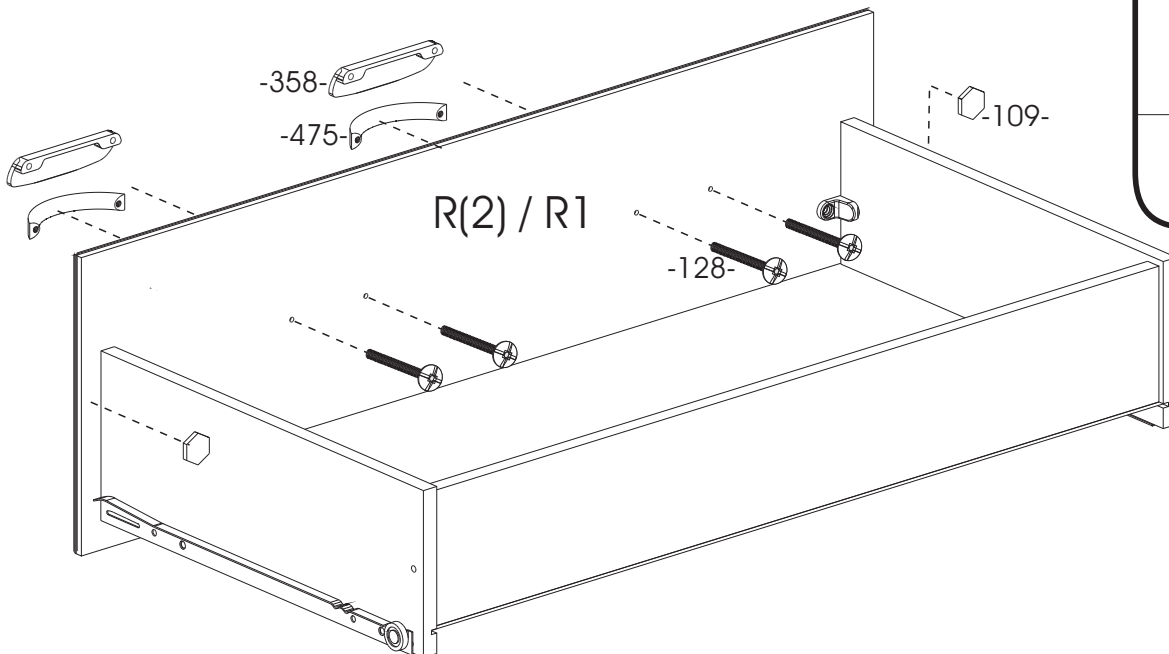

12

Required/Requis/Requerido

X12

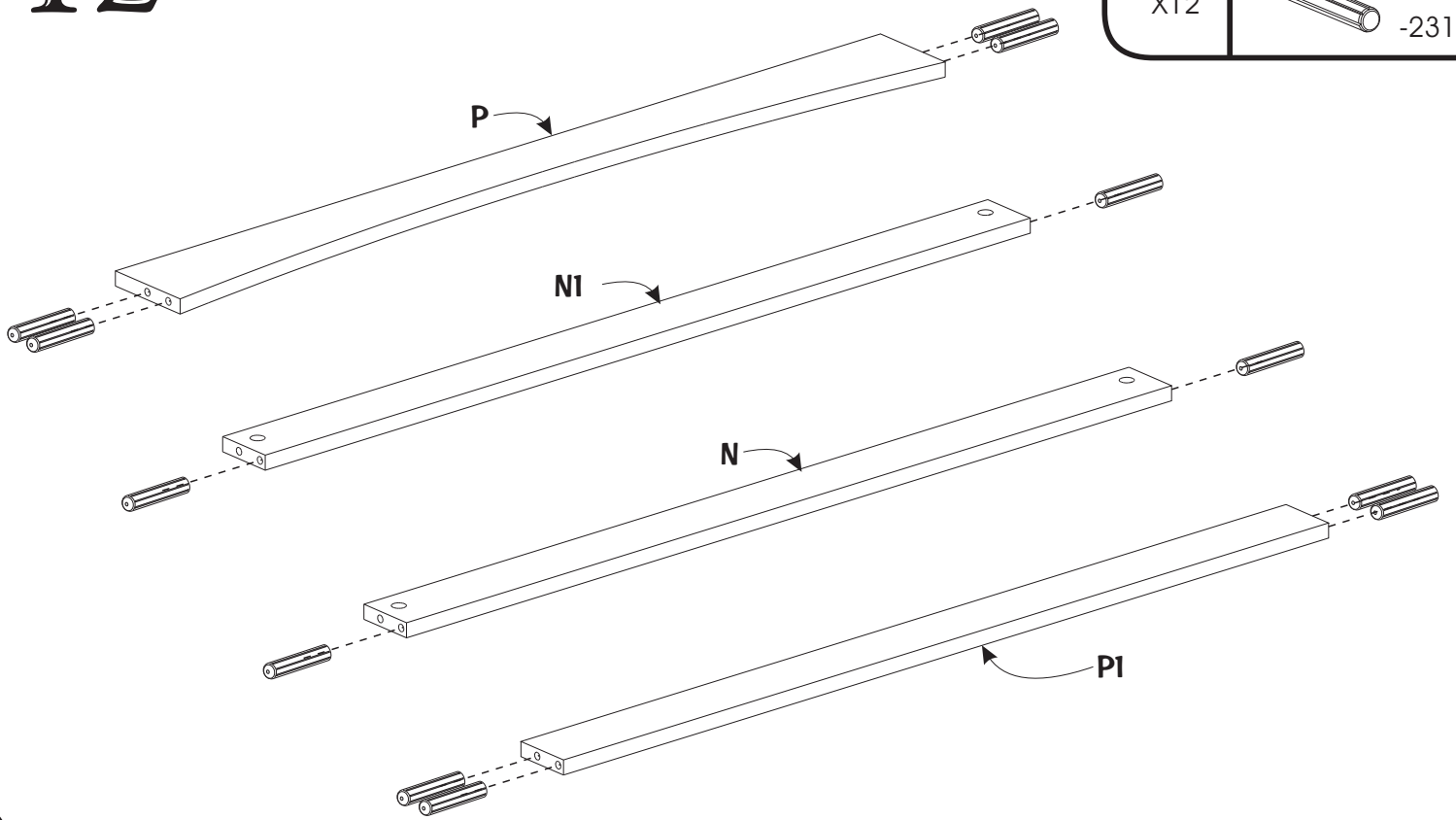
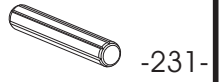

13

Required/Requis/Requerido

X16

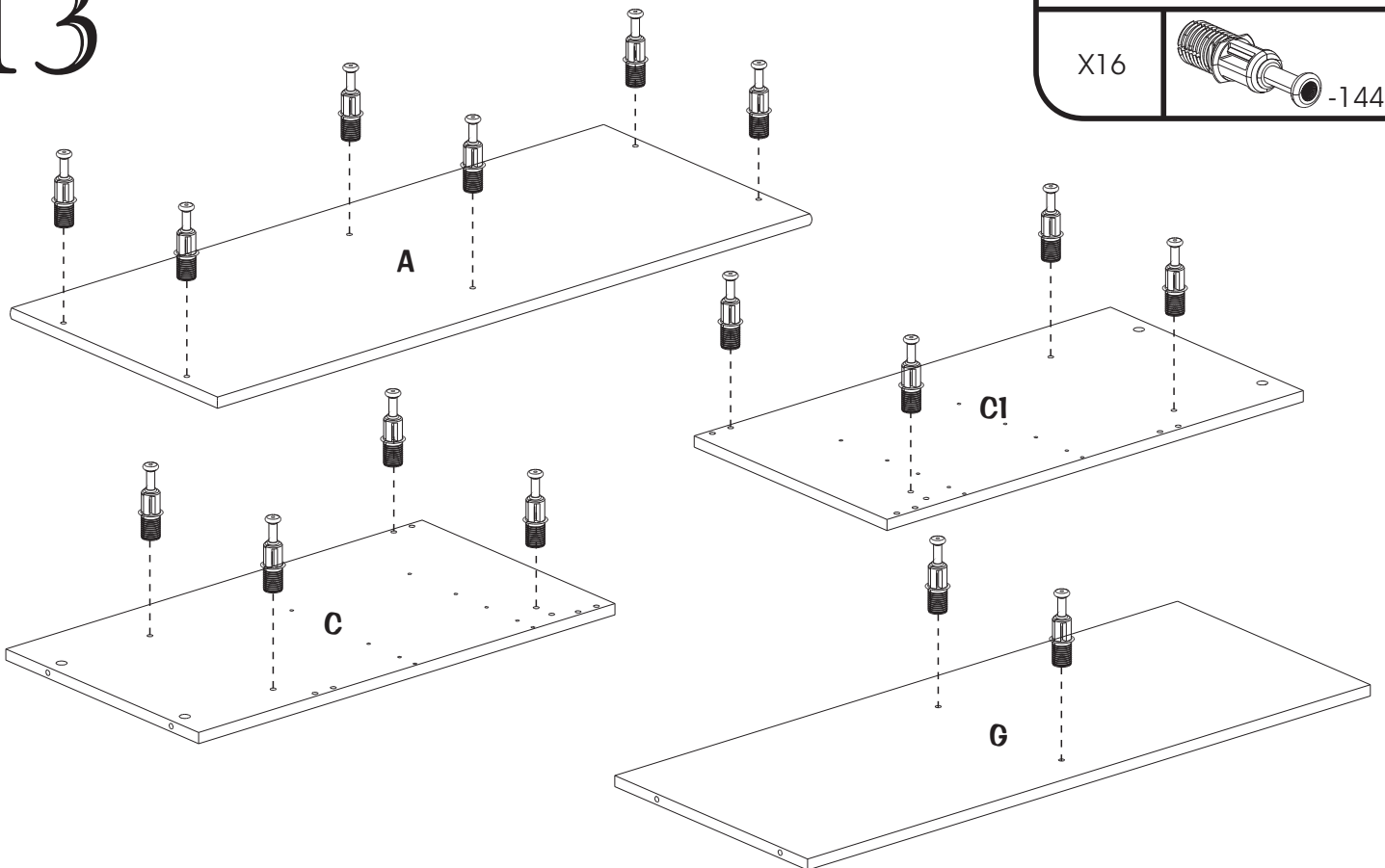
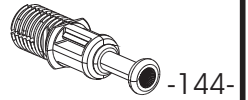

14

Required/Requis/Requerido

X16

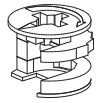

-158-

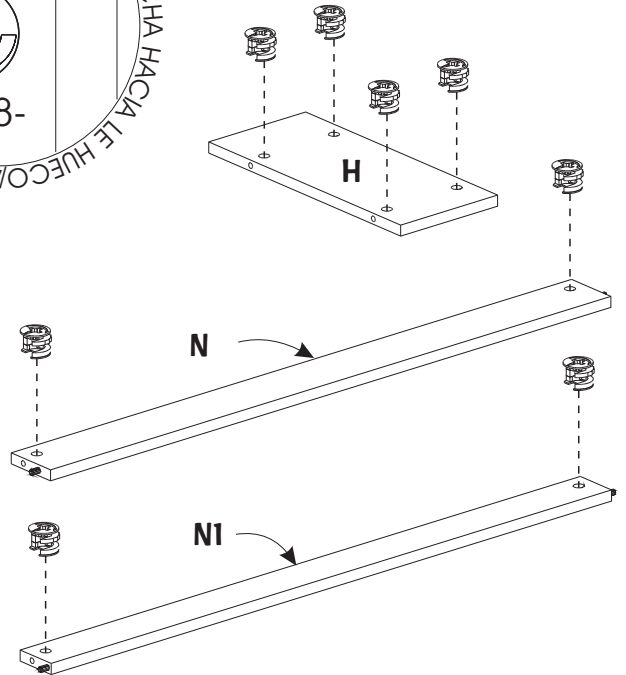
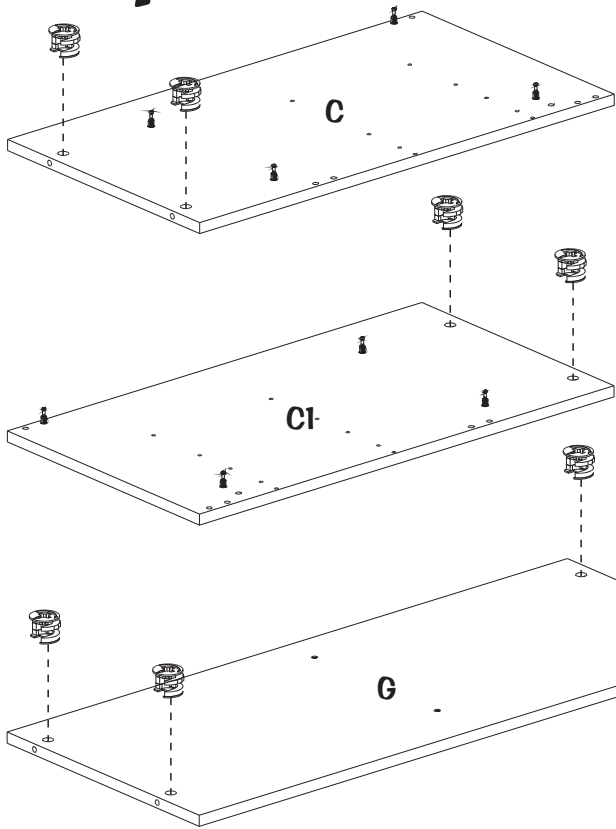

15

Required/Requis/Requerido

X2

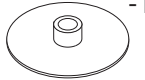

-171-

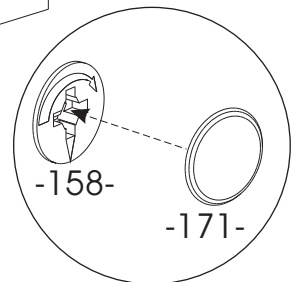
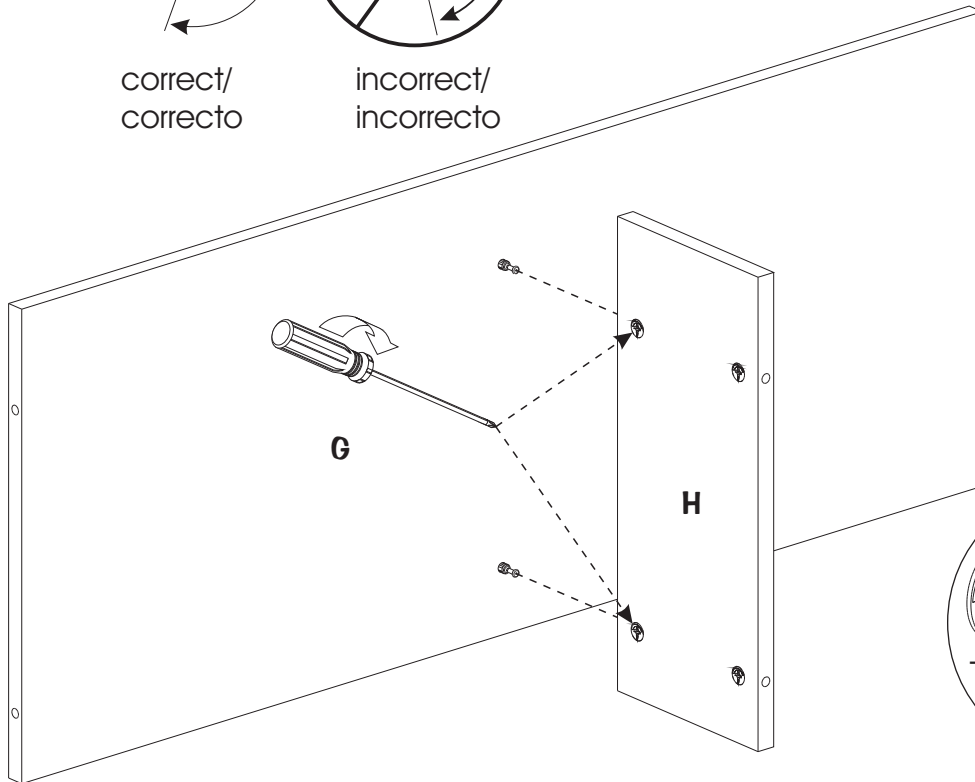
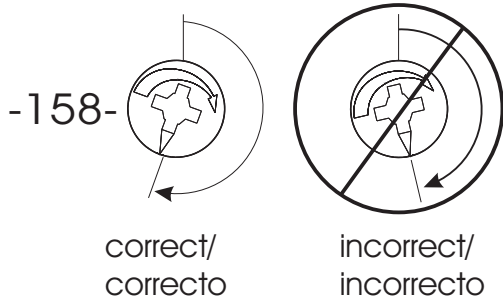

16

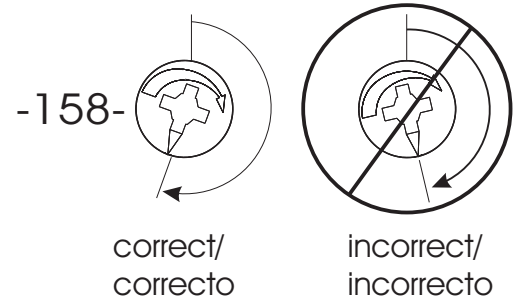
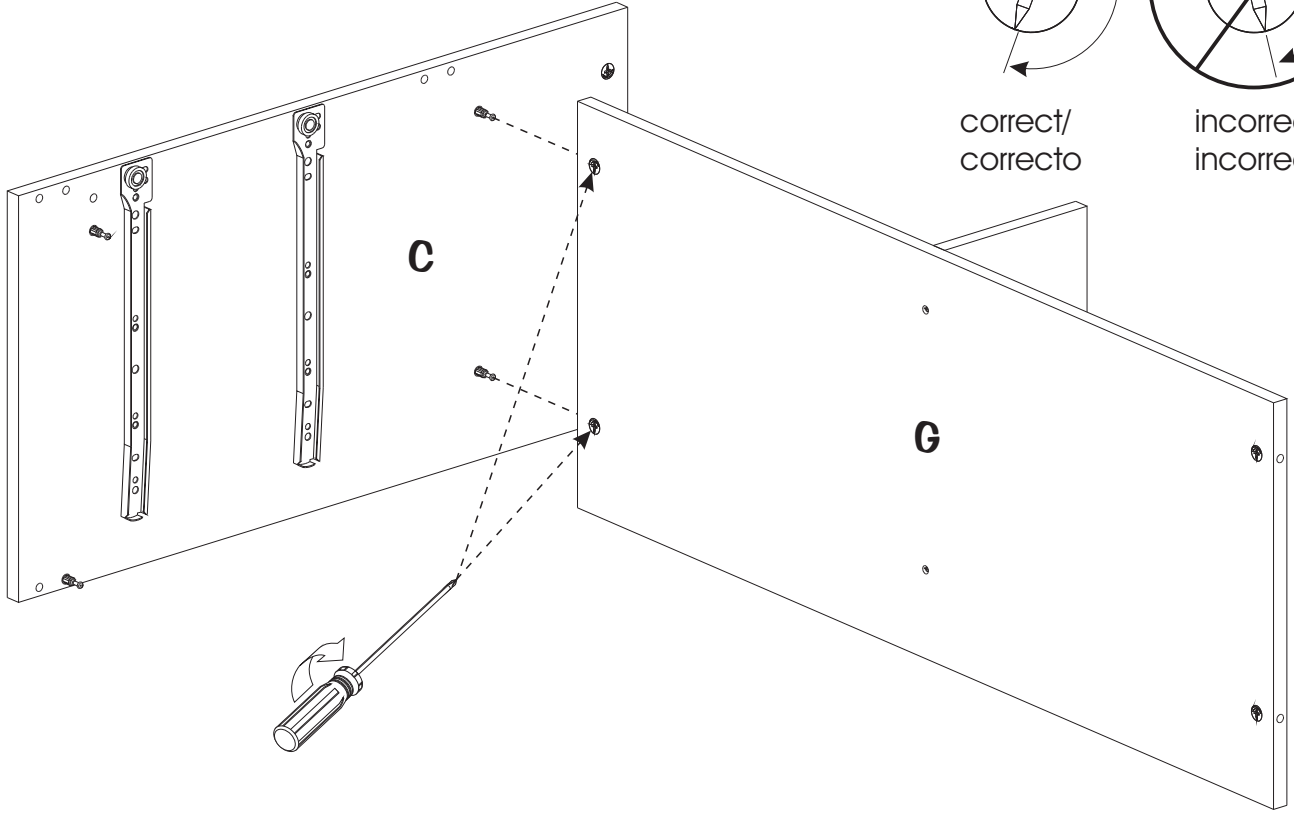

17

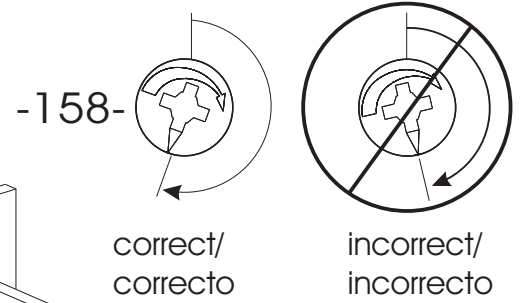
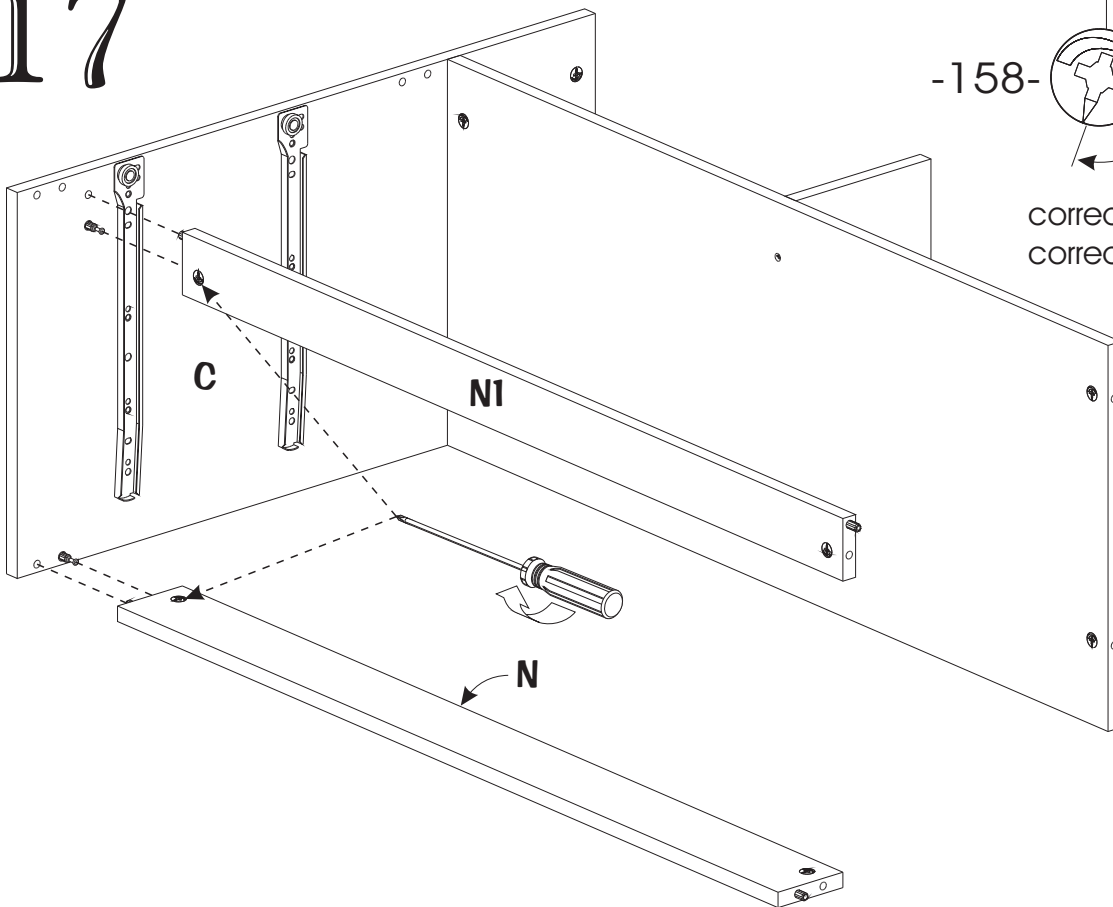

18

-158-



correct/
correcto

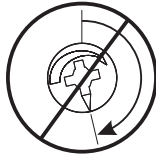

incorrect/
incorrecto

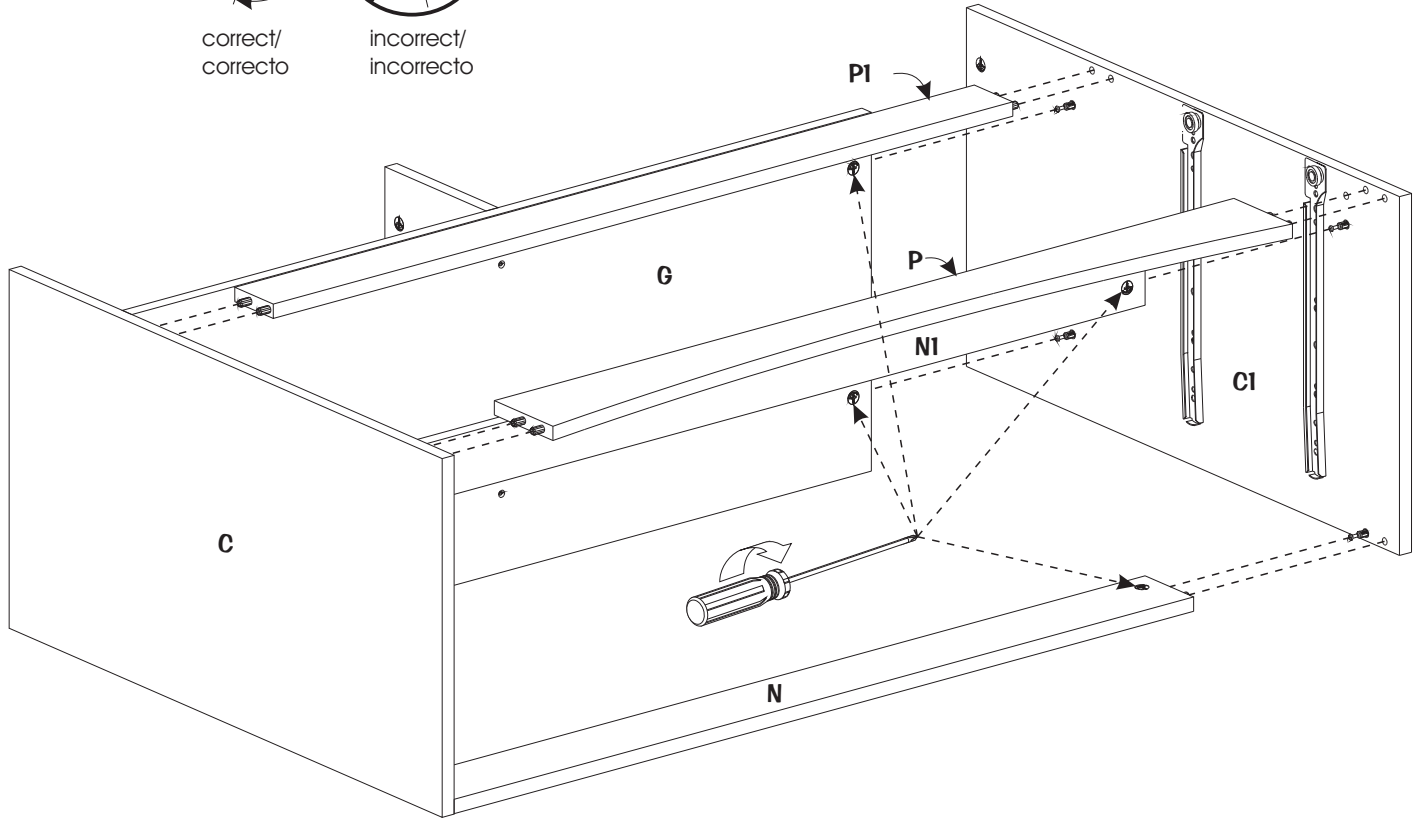

19

-158-



correct/
correcto

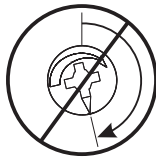

incorrect/
incorrecto

Required/Requis/Requerido

X4

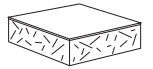

-6-

X6

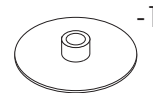

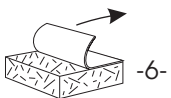
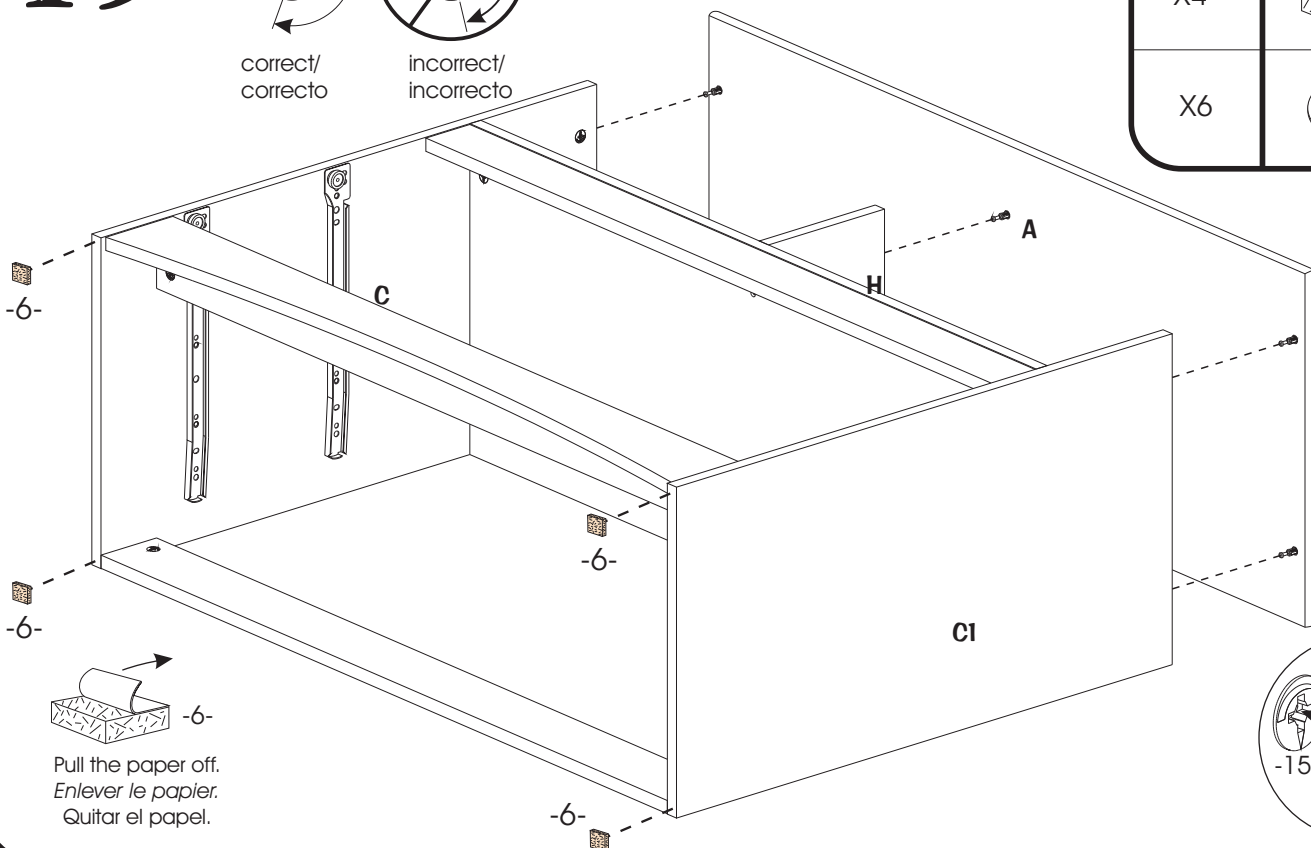

-171-



Pull the paper off.
Enlever le papier.
Quitar el papel.

20

Required/Requis/Requerido

X22	 -90-
X3	 -99-

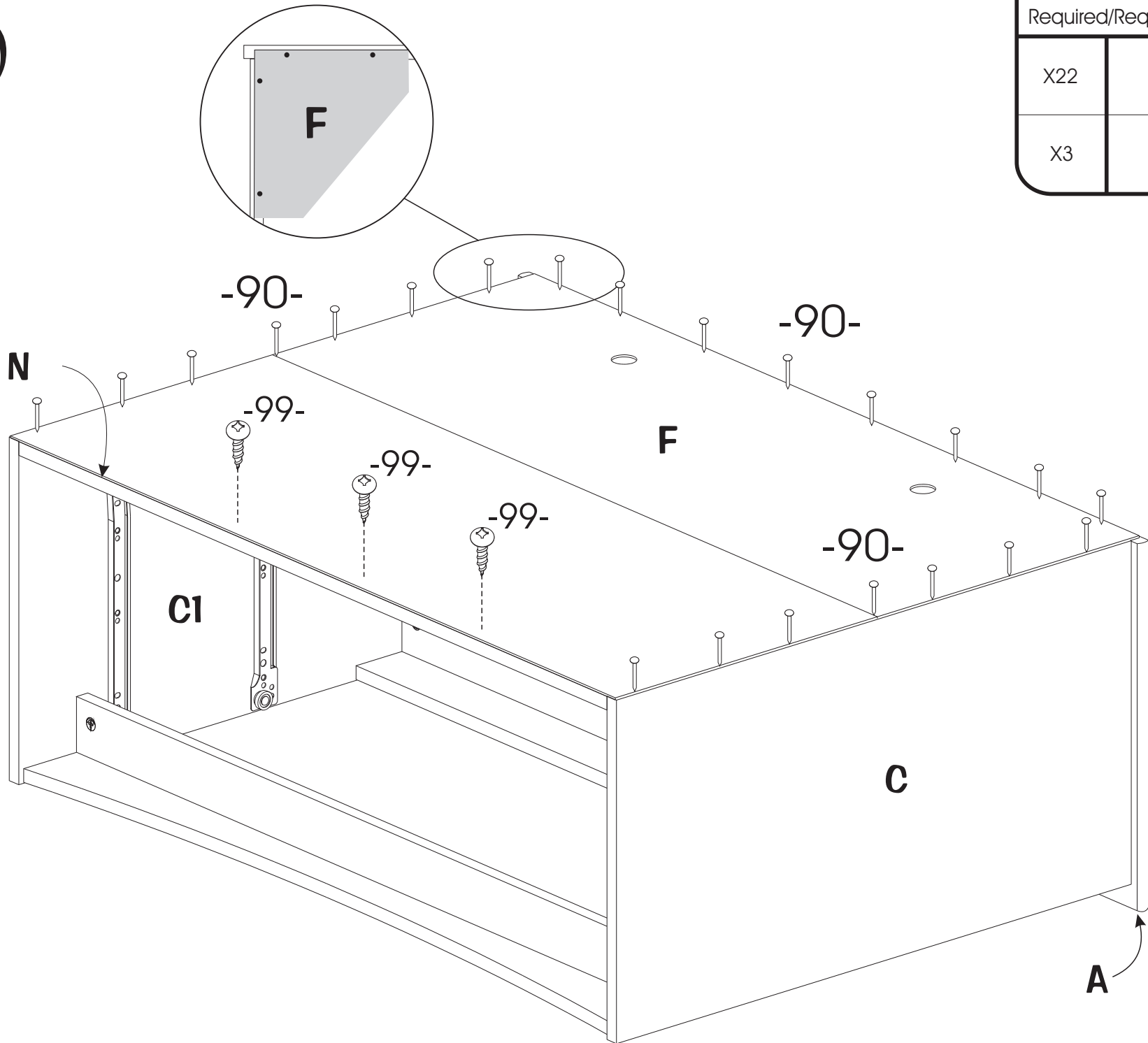

21

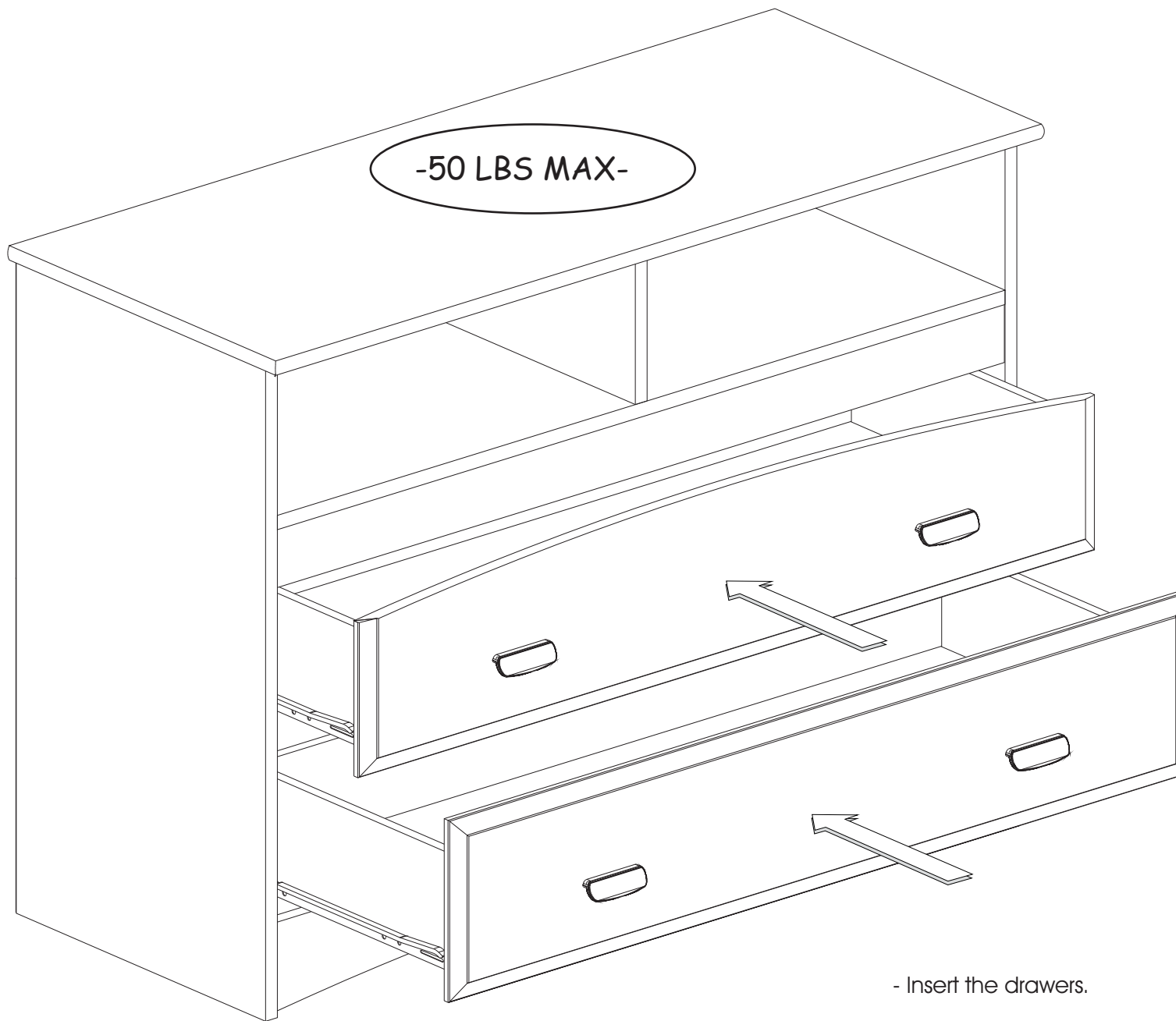

-50 LBS MAX-

- Insert the drawers.

- Insérer les tiroirs.

- Insertar los cajones.

5 YEAR LIMITED WARRANTY

GARANTIE LIMITÉE DE 5 ANS

GARANTIA LIMITADA DE 5 AÑOS

1. South Shore™ Furniture provides the original buyer with a warranty covering "defects" on furniture parts and workmanship for a period of 5 years from the date of purchase.
2. The word "defect" as used in this warranty is defined as any imperfection that may impair the intended use of the product.
3. This warranty is strictly limited to the repair or replacement of defective component parts, and excludes all other direct or indirect charges and expenses up to the limit permitted by law in your state/province.
4. In the case of a discontinued part or product, South Shore™ Furniture promises to reimburse the value of that part or product.
5. If a replacement part is unavailable, South Shore™ Furniture's liability to the buyer will not exceed the production cost of the part in question.
6. This warranty only applies under conditions of normal domestic use. It does not cover defects resulting from commercial use, intentional damage, negligence, abuse, product modification, accidents, exposure to the elements, or maintenance that does not comply with the guidelines on our website.
7. To honor this warranty, South Shore™ Furniture reserves the right to verify the grounds of any request and to ask for the original buyer's proof of purchase.
8. This warranty is only valid on purchases made at authorized South Shore™ Furniture retailers in Canada, the U.S., Mexico, Puerto Rico and Bermuda.
9. This warranty defines the limits of South Shore™ Furniture's liability, and entitles the original buyer to specific rights. Any warranty defined by law in your state/province is limited to a period of 5 years. If the law in your state/province prohibits this restriction, then it does not apply.
10. South Shore™ Furniture will not reimburse defective furniture, but will replace it with an item of equivalent value.

To qualify for your warranty, please take a moment to fill out our on-line registration form (southshorefurniture.com)

Afin de bénéficier de votre garantie, nous vous invitons à remplir le formulaire d'enregistrement en ligne (meublesrivesud.com)

Para obtener su garantía, tenga a bien llenar nuestro formulario en línea (southshorefurniture.com)

1. Meubles South Shore™MC garantit à l'acheteur original, pour une période de 5 ans à partir de la date d'achat, toutes les composantes des meubles contre les «défauts» de matériaux et de main-d'œuvre.
2. Le mot «défaut» utilisé dans cette garantie signifie une imperfection pouvant altérer l'utilité pour laquelle le produit est destiné.
3. Cette garantie se limite strictement à la réparation ou au remplacement des pièces composantes défectueuses. Cette garantie exclut tous les autres frais et dépenses directs ou indirects et ce, jusqu'à la limite permise par la législation en vigueur dans votre lieu de résidence.
4. Dans le cas d'une réclamation concernant un produit ou une pièce discontinuée, Meubles South Shore™MC s'engage à rembourser la valeur du produit ou de la pièce en question.
5. À défaut de pouvoir fournir la pièce de remplacement, la responsabilité de Meubles South Shore™MC ne peut excéder la valeur équivalente au coût de production de la pièce en litige.
6. Cette garantie s'applique sous des conditions d'usage domestique normal et ne couvre pas les défauts pouvant résulter d'un usage commercial, de dommages intentionnels, de la négligence, de l'usage abusif, de modifications personnelles, d'un accident, de l'exposition aux éléments ou d'un entretien ne respectant pas les conseils décrits sur notre site Internet.
7. Comme condition pour fournir une pièce de remplacement, Meubles South Shore™MC se réserve le droit de vérifier le fondement de la requête, de même que d'exiger la preuve d'achat de l'acheteur original.
8. Cette garantie n'est valide que si et seulement si l'achat a été effectué chez un marchand autorisé par Meubles South Shore™MC au Canada, aux États-Unis, au Mexique, à Puerto Rico et aux Bermudes.
9. Cette garantie définit les limites de la responsabilité de Meubles South Shore™MC et donne à l'acheteur original des droits spécifiques. Toute garantie législative prévalant dans votre lieu de résidence est limitée à une période de 5 ans. Si cette restriction n'est pas permise par la législation de votre lieu de résidence, elle ne s'applique pas.
10. Meubles South Shore™MC ne remboursera pas un meuble défectueux, mais le remplacera par un autre de valeur équivalente.



1. South Shore™MR garantizan al comprador original, por un período de 5 años a partir de la fecha de compra, todas las piezas que componen el mueble contra los «defectos» de material y mano de obra.
2. La palabra «defecto» utilizada en esta garantía se define como toda imperfección que pueda alterar la utilidad para la cual se destina el producto.
3. Esta garantía se limita estrictamente a la reparación o reemplazo de las piezas que tengan componentes defectuosos. Esta garantía no incluye cualquier gasto directo o indirecto hasta el límite permitido por la legislación vigente en su lugar de residencia.
4. En el caso de una reclamación referente a un producto o pieza discontinuada, South Shore™MR se compromete a reembolsar el valor del producto o pieza en cuestión.
5. A falta de poder suministrar la pieza de repuesto, la responsabilidad de South Shore™MR no puede exceder el valor equivalente al costo de producción de la pieza en litigio.
6. Esta garantía se aplica bajo las condiciones de uso doméstico normal y no cubre los defectos que puedan resultar de un uso comercial, daños intencionales, negligencia, uso abusivo, modificaciones personales, un accidente, exposición a los elementos y mantenimiento sin respetar los consejos que se describen en este sitio web.
7. Como condición para suministrar una pieza de repuesto, South Shore™MR se reservan el derecho de verificar el fundamento de la solicitud, así como de exigir la prueba de compra del comprador original.
8. Esta garantía sólo será válida si la compra se efectuó en un comercio autorizado por Meubles South Shore™MR de Canadá, Estados Unidos, México, Puerto Rico o las Bermudas.
9. Esta garantía define los límites de la responsabilidad de South Shore™MR y otorga al comprador original los derechos específicos. Cualquier garantía legislativa que prevalece en su lugar de residencia está limitada a un período de 5 años. Si esta restricción no está permitida por la legislación de su lugar de residencia, ésta no se aplica.
10. South Shore™MR no hará ningún reembolso por muebles defectuosos, pero le enviará uno de valor equivalente.

CUSTOMERS SERVICE / SERVICE À LA CLIENTÈLE / SERVICIO A CLIENTELE

CANADA / USA

 **1-800-290-0465** 

MEXICO

 **001-800-514-5320** 
toll free number / lada sin costo

INTERNATIONAL

 **418-926-2961** 



6168, Rue Principale, C.P. 190
SAINTE-CROIX, QUÉBEC
CANADA, G0S 2H0



FAX: 1-877-586-5339
(CANADA / USA)



E-MAIL: service@southshore.ca
WEB: www.southshore.ca

