

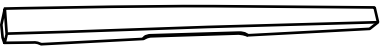
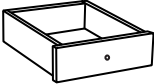
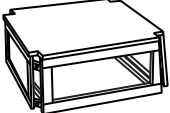

HARDWARE KIT - SKU 976-48BP01

NO	DESCRIPTION	Q'TY
A	HEX BOLT 5/16"x2.1/2"	12 PCS
B	FLAT WASHER 5/16"	12 PCS
C	LOCK WASHER 5/16"	12 PCS
D	WRENCH	1 PCE
E	TRUSS HEAD SCREW 5/32x7/8"	2 PCS

TABLE PARTS KEY

NO	SKU	FIGURE	DESCRIPTION	Q'TY
1.	976-48TP02		Leg	4 pcs
2.	976-48BP05		Pull-Thru Drawer	1 pce
3.	976-48BP51		Table Base Storage Box	1 pce
4.	976-48BP04		Knob	2 pce
5.	976-48T		Table Top	1 pce

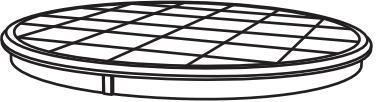
STEP 1

Line up pre-drilled holes of Leg(1.) with Corner Block inside Storage Box(3.) and affix with Flat Washer(B) , Lock Washer(C) and Hex Bolt(A), tightening with provided Wrench(D). Repeat step for each Leg.

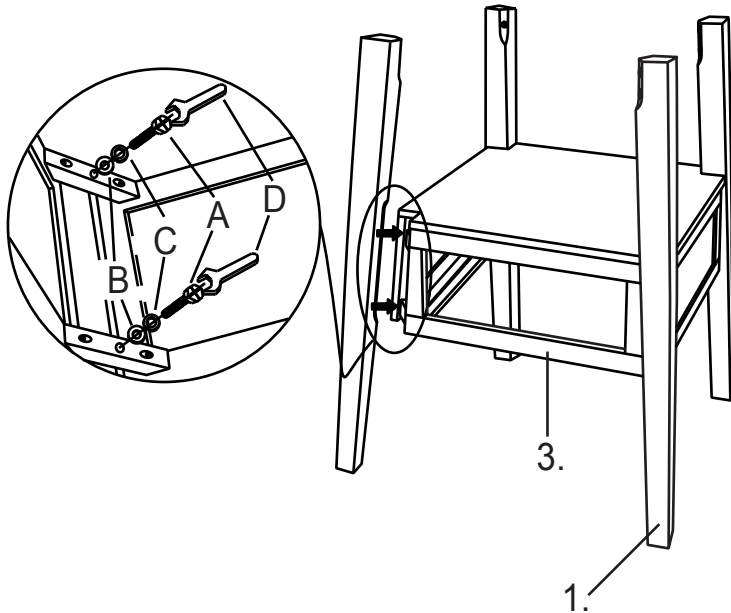

STEP 2

Pull out the Drawer and then install the Knob(4.) with the Truss Head Screw(E). Repeat the same for the other side.

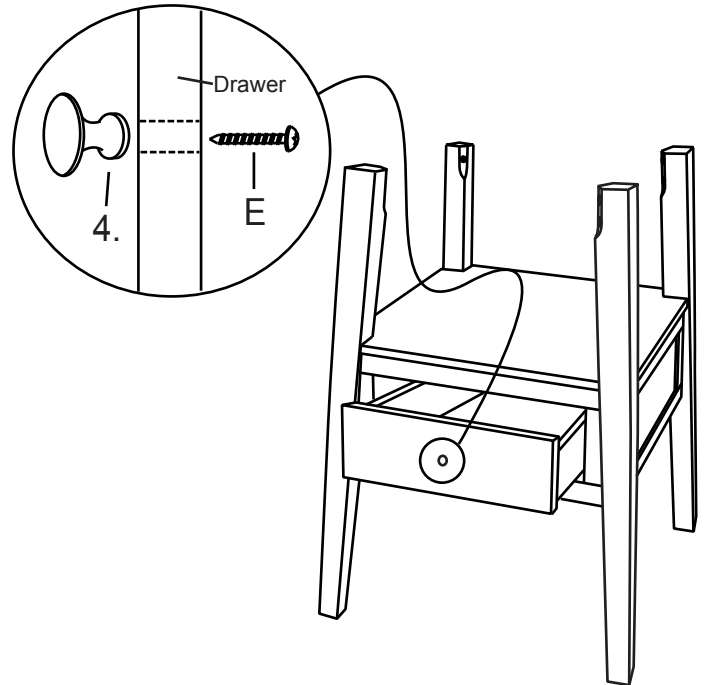

STEP 3

Affix top of legs to corner blocks fixed to the underside of the table top. Insert Hex Bolt (A) through Lock Washer (C) and Flat Washer (B) and through pre-drilled holes of corner blocks to table legs, tightening with provided Wrench (D). Repeat step for all legs.

