

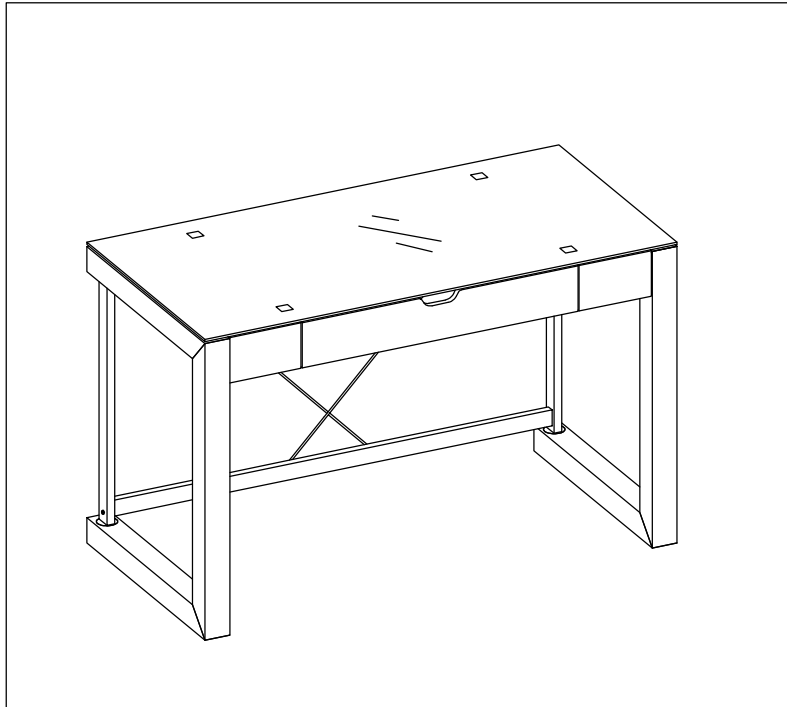

ZLN # ZL650-01DU



⚠ DO NOT return to the store if parts are missing or damaged.

For Parts Replacements and Inquiries, please call us Toll-Free 1-888-736-2141 or E-mail CustomerService@Z-LineDesigns.com

To ensure a timely delivery, please include the following:

1. Full Name
2. Physical Address (Our primary carrier, FedEx, will NOT deliver to P.O. Boxes)
3. Phone Number
4. QC Number : SF
5. ZLN Number : ZL650-01DU_V00
6. Part Number(s) or Letter(s)
7. Quantity
8. We also request that you please provide a brief description of the reason for your request.

Our Customer Service Representatives will be available to assist you Monday - Friday 7:00 am to 3:30 pm Pacific Standard Time (Except Holidays).

Important

 TWO PEOPLE ARE NECESSARY FOR THE ASSEMBLY OF THIS PRODUCT.

Before you begin: Lay out all of the parts on a non-abrasive surface in order to identify and count prior to assembly. You will need the parts and hardware listed on this instruction manual as well as the tools shown below to assemble this unit.

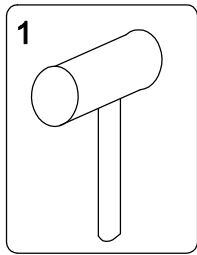

1. RUBBER MALLET

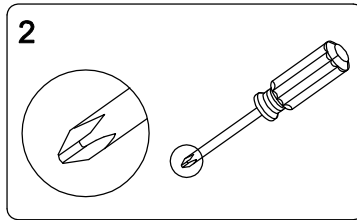

2. PHILLIPS HEAD SCREWDRIVER

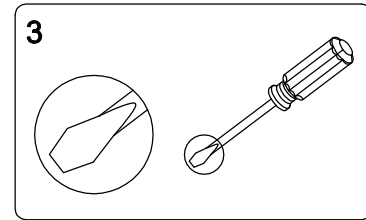

3. FLAT HEAD SCREWDRIVER

Insert Dowels ABOUT 2/3 into the Edges of the panels. IF NECESSARY tap Dowels Lightly with a rubber mallet.

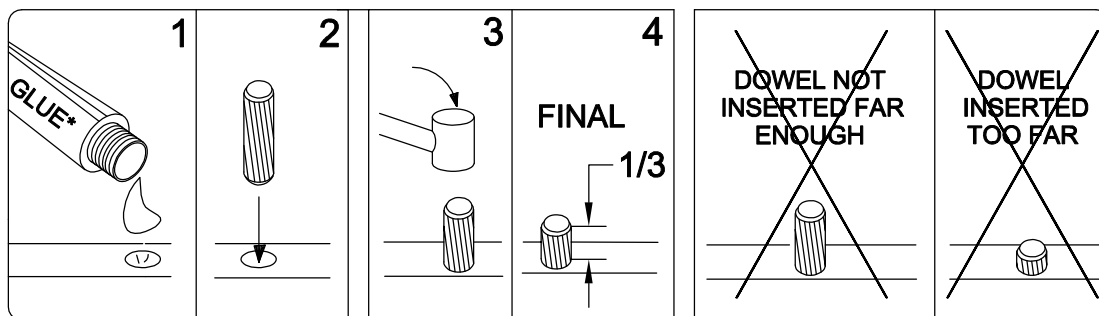







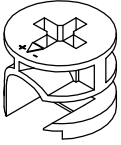

***PLEASE NOTE:** IT IS VERY IMPORTANT TO USE GLUE WITH DOWELS. EXCESS GLUE CAN BE WIPED OFF WITH A DAMP CLOTH.

NOW YOU ARE READY TO BEGIN ACTUAL ASSEMBLY!

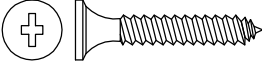
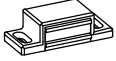
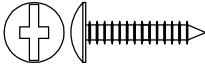
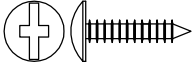
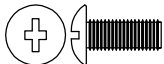





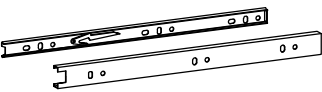

WARNING - Failure to follow these installation instructions or any other abuse, mistreatment, unreasonable use or neglect of the product shall constitute a waiver of all warranties, expressed and implied, and constitute a waiver of all claims of liability against Z-Lines Designs, Inc., its directors, officers, shareholders, parents, subsidiaries, affiliates, agents, customers and licensors, for any direct, indirect, special (including loss of revenue or income, pain and suffering, emotional distress, or similar damages), incidental, punitive, or consequential damages arising out of or resulting from the improper installation, abuse, mistreatment, unreasonable use or neglect regardless of whether such damages arise in contract, tort, under statute, in equity, at law, or otherwise.

HARDWARE IDENTIFICATION

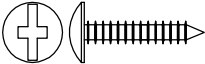

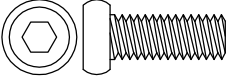
A		GLUE	1 PC
B		LARGE WOOD DOWEL (WD830)	16 PCS
C		CAM SCREW (CSMT6835BR)	14 PCS
D		CAM LOCK (CL1512BL)	14 PCS
E		SMALL WOOD DOWEL (WD620)	2 PCS
F		4x25x8mm WOOD SCREW (FHWS4258BL)	4 PCS
G		MAGNET	2 PCS
H		3x16x6mm WOOD SCREW (RHWS3166BL)	4 PCS
I		3x14x6mm WOOD SCREW (RHWS3146BL)	4 PCS
J		4x10x8mm MACHINE SCREW (MS4108BL)	4 PCS
K		6x35x10mm ALLEN BOLT (AB63510BL)	6 PCS
L		6x60x10mm ALLEN BOLT (AB66010BL)	4 PCS
M		ALLEN WRENCH (AW4BL)	1 PC

*Extra hardware is enclosed for your convenience.



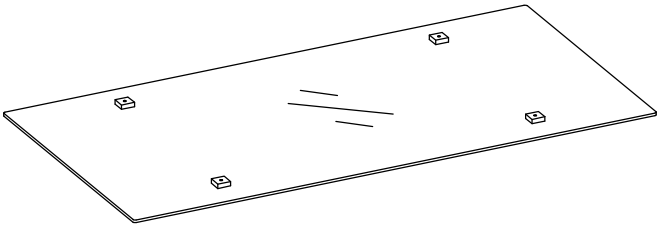
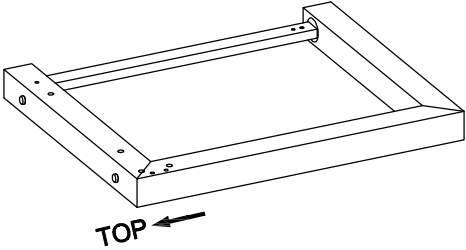
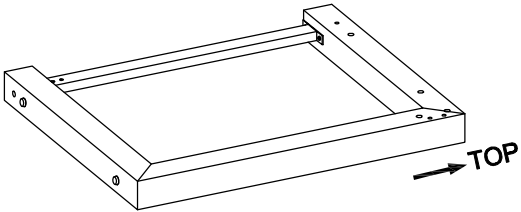
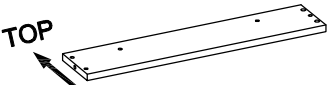
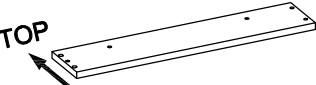

THE BELOW PARTS ARE PRE-ASSEMBLED AND ARE LISTED AS A REFERENCE ONLY.

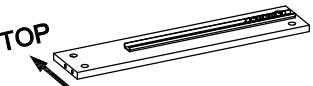
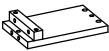
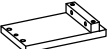
N		KEYBOARD GLIDE (14")	2 SETS
O		HINGE	2 PCS
P		MAGNET PLATE	2 PCS
Q		3x16x6mm WOOD SCREW (RHWS3166BL)	4 PCS
R		PLASTIC BASE TACK (PBT)	9 PCS
S		6x15x10mm ALLEN BOLT(AB61510BL)	4 PCS
T		6x60x10mm ALLEN BOLT(AB66010BL)	2 PCS
U		6x50mm DOUBLE THREADED BOLT	2 PCS
V		DIA50mm METAL SHEET	2 PCS
W		3.5x12x6mm WOOD SCREW (FHWS35126BL)	16 PCS

PARTS IDENTIFICATION-1

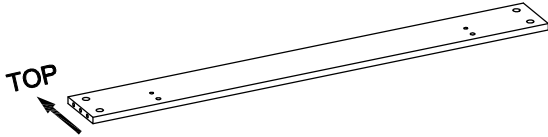
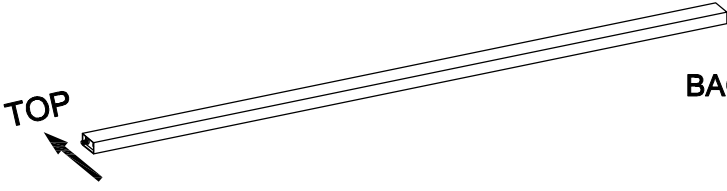
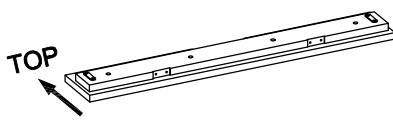
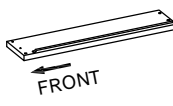
1		TOP GLASS SHELF	1 PC
2		LEFT SIDE FRAME	1 PC
3		RIGHT SIDE FRAME	1 PC
4		LEFT SIDE PANEL	1 PC
5		RIGHT SIDE PANEL	1 PC
6		LEFT MIDDLE PANEL	1 PC
7		RIGHT MIDDLE PANEL	1 PC
8		LEFT FRONT SIDE PANEL	1 PC
9		RIGHT FRONT SIDE PANEL	1 PC

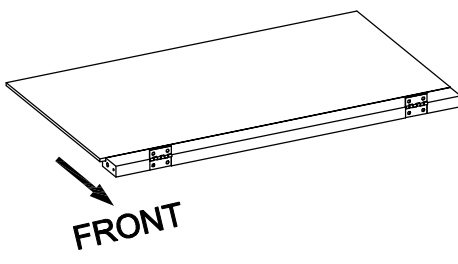
PARTS IDENTIFICATION-2

10		BACK PANEL	1 PC
11		BACK CROSSBAR	1 PC
12		FRONT KEYBOARD PANEL	1 PC
13		LEFT KEYBOARD PANEL	1 PC
14		RIGHT KEYBOARD PANEL	1 PC
15		BACK KEYBOARD PANEL	1 PC
16		BOTTOM KEYBOARD PANEL	1 PC
17		TENSION BAR	2 PCS

ASSEMBLY INSTRUCTION

STEP 1

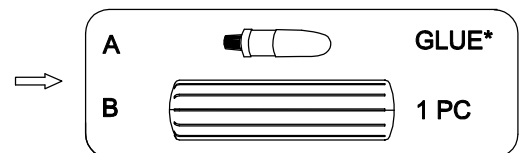
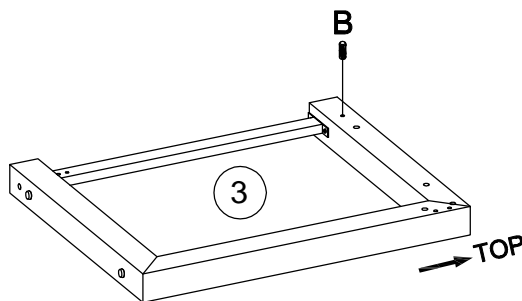
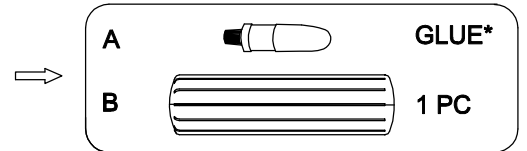
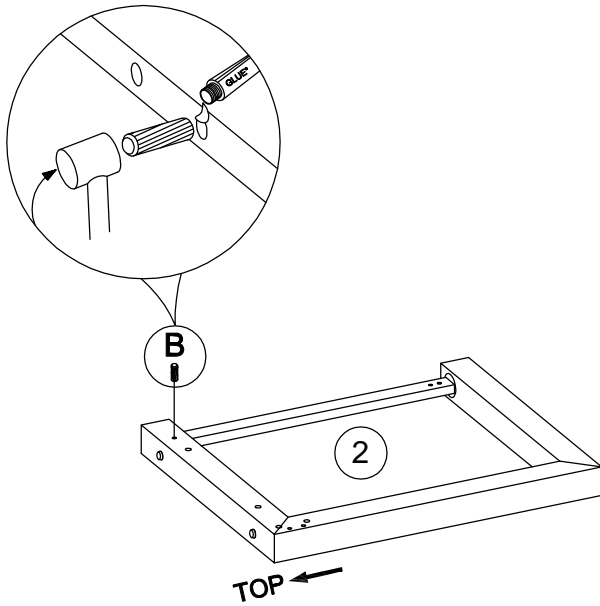
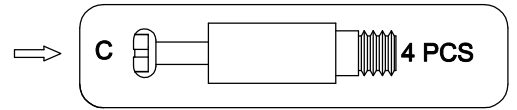
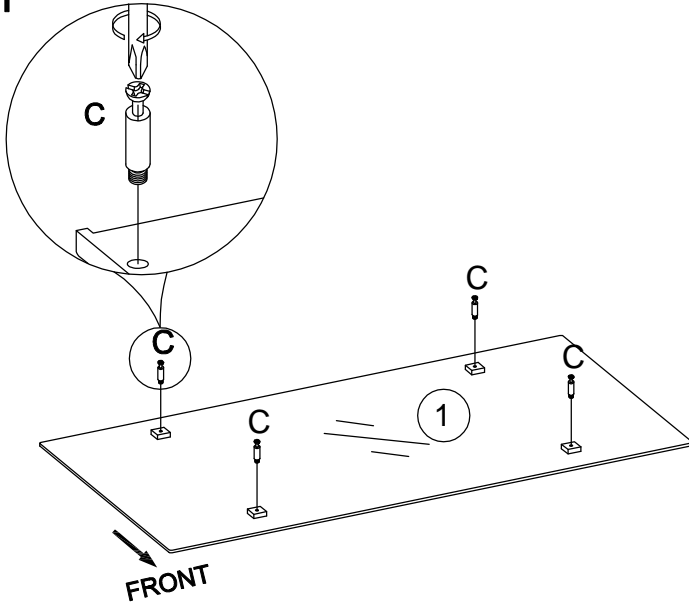

*Step 1 continued on next page

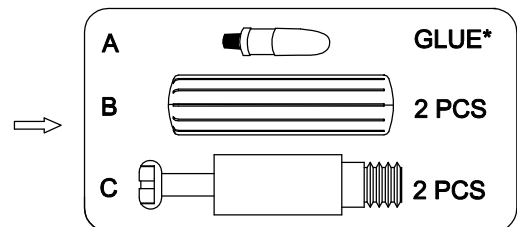
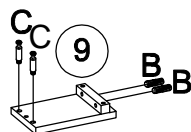
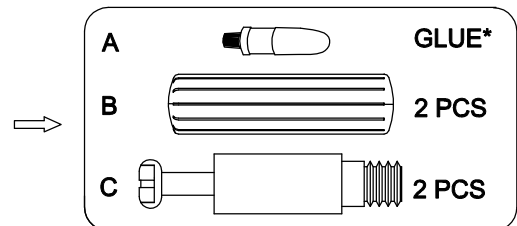
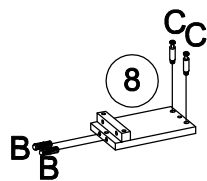
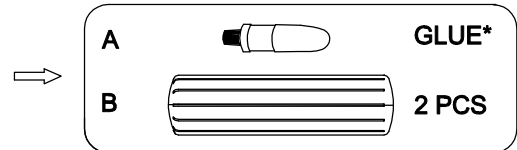
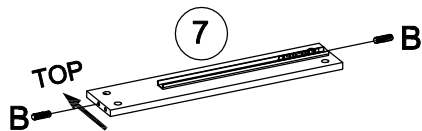
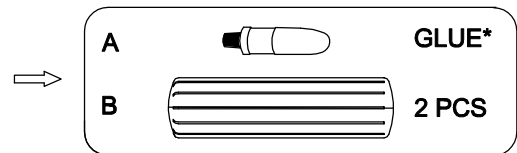
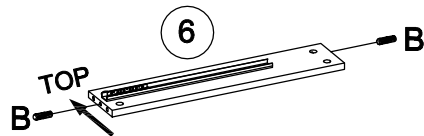
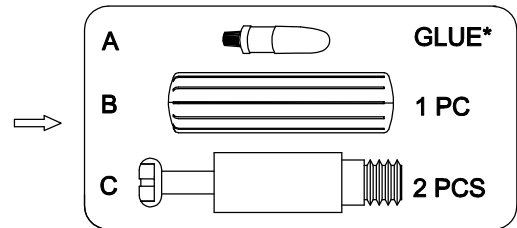
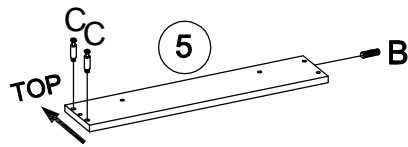
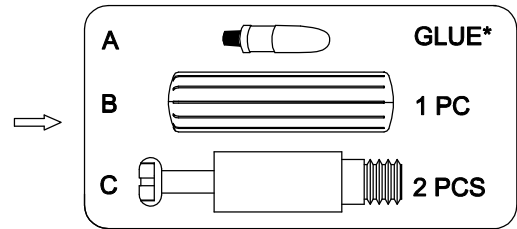
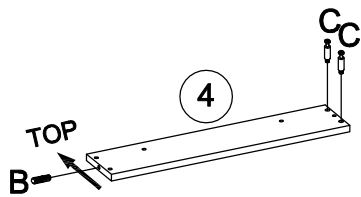

***Step 1 continued on next page**

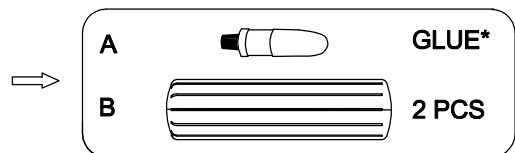
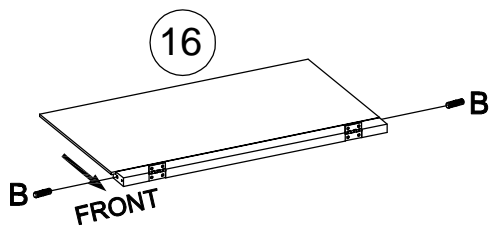
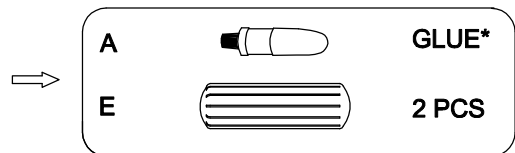
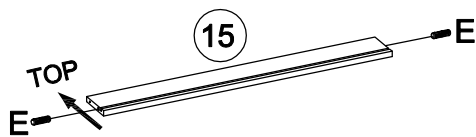
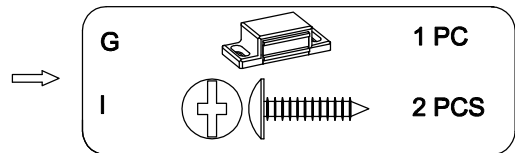
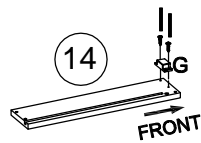
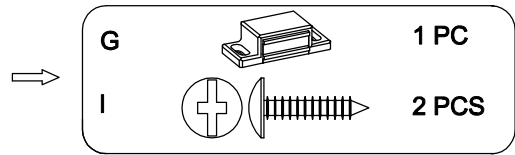
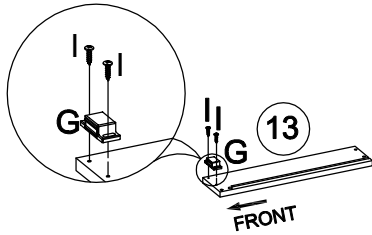
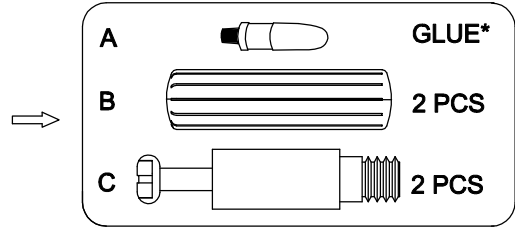
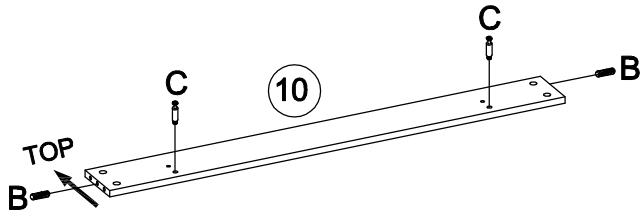

Cam Lock/Dowel Placement Supplement

CORRECT

1

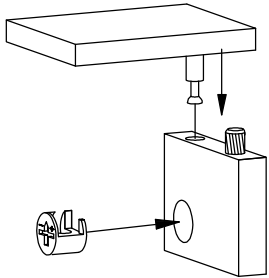

When inserting the Cam Lock, make sure that the Open End of the Cam Lock faces the Cam Screw Entry. The Dowel will be inserted in the hole NEXT to the Cam Lock/Cam Screw Hole.

INCORRECT

2

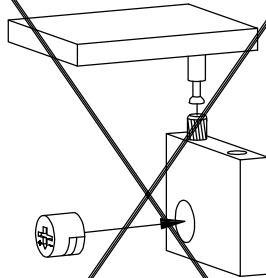

The Cam Lock is backwards in this illustration. The Cam Screw can not connect to the Cam Lock because the Dowel is in the incorrect hole.

3

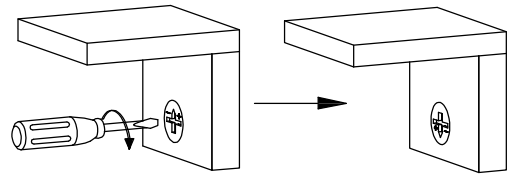

To tighten, turn the Cam Lock **CLOCKWISE** until the arrow or "+" & "-" signs point **AWAY** from the connected Panel.

***NOTE: DO NOT USE AN AUTOMATIC SCREWDRIVER TO TIGHTEN CAM LOCKS, DO NOT OVER-TIGHTEN.**

STEP 2

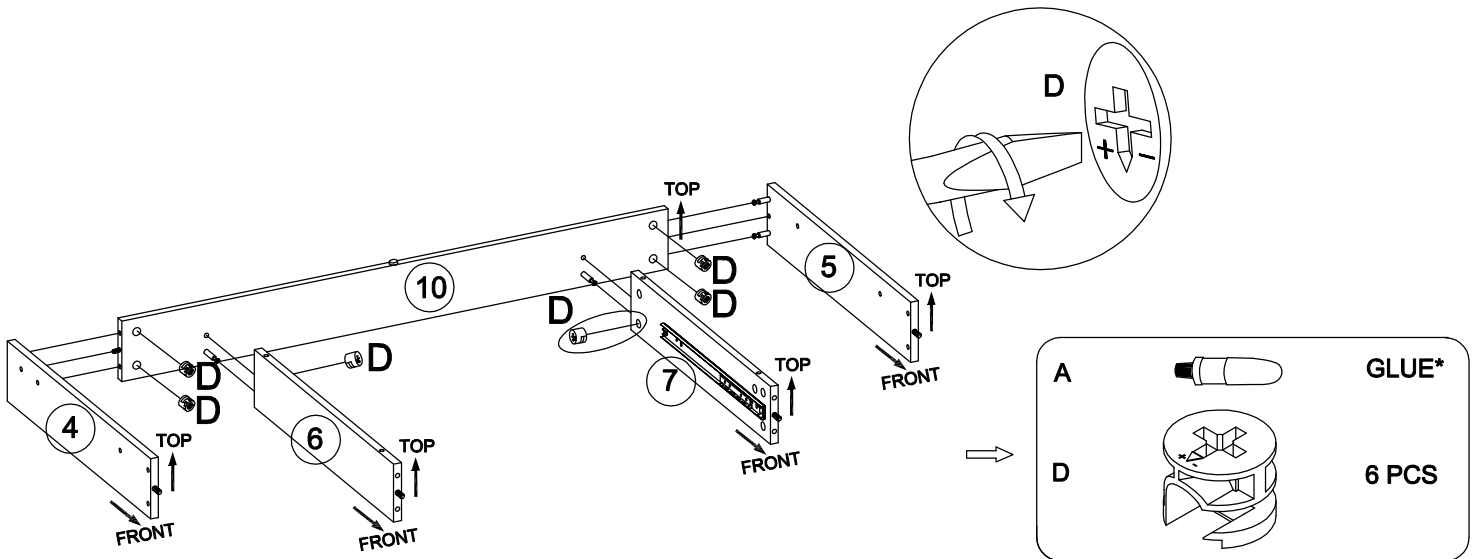

STEP 3

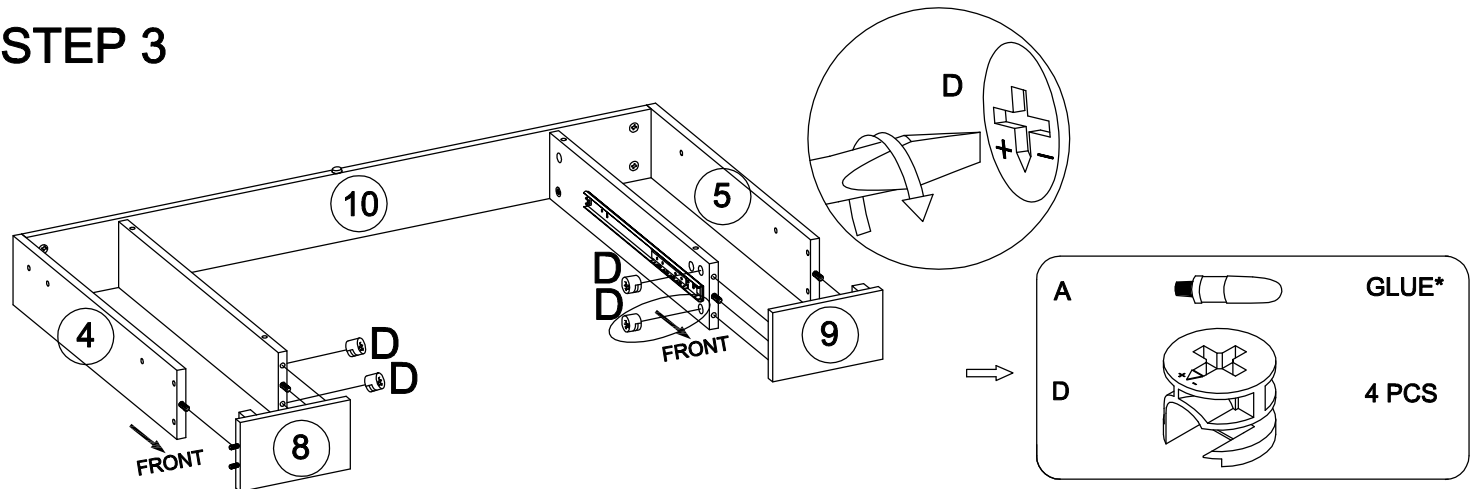

STEP 4

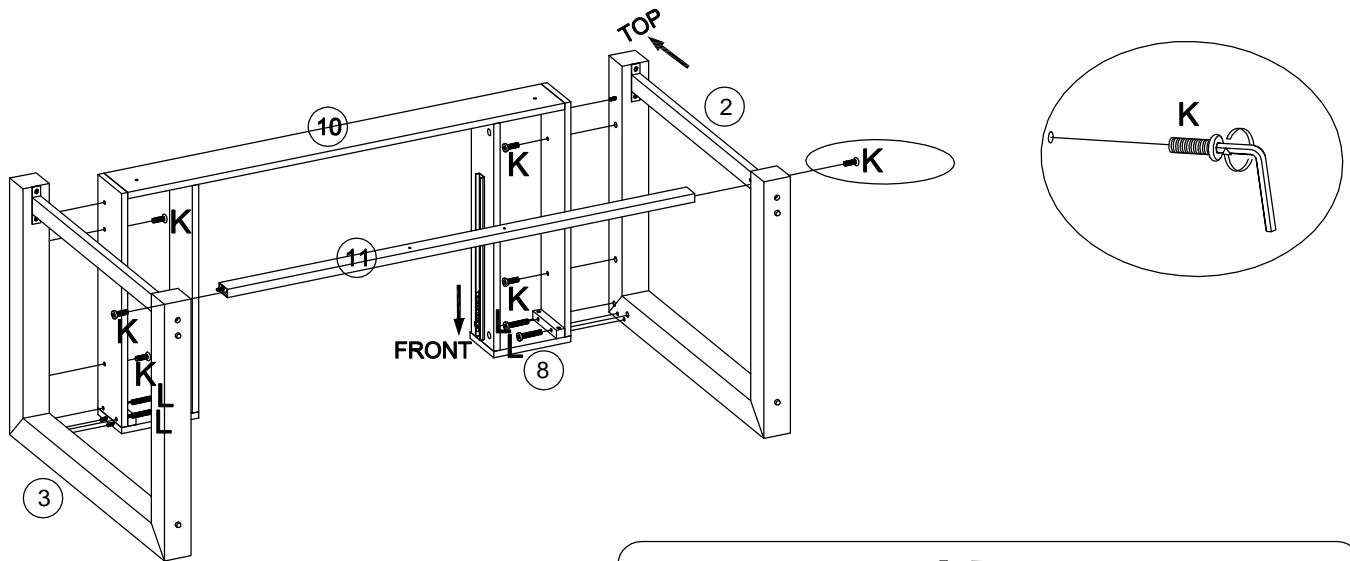

A		GLUE*
K		6 PCS
L		4 PCS
M		

STEP 5

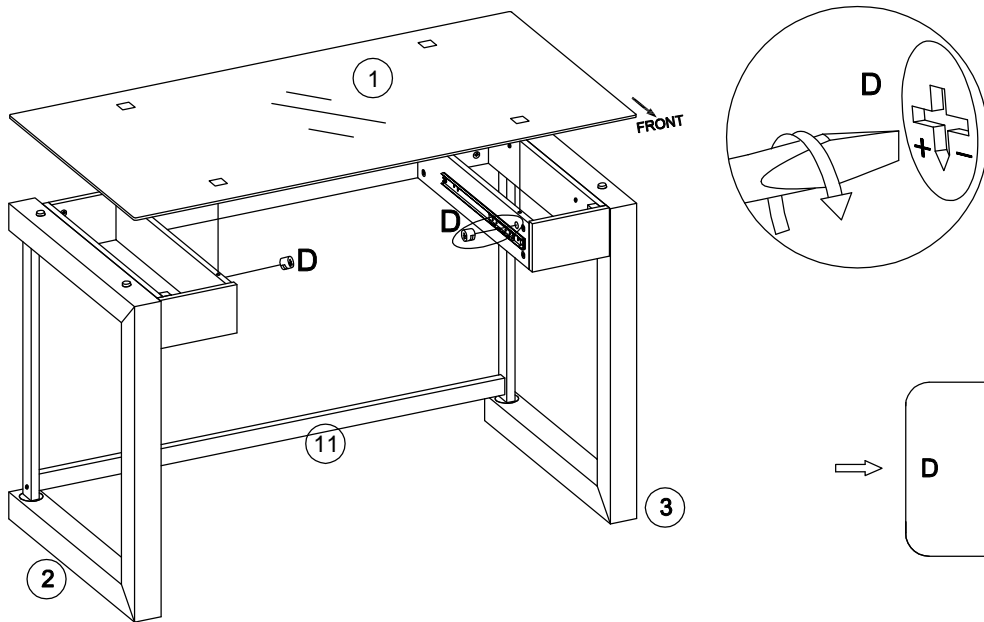

D		4 PCS
---	--	-------

STEP 6

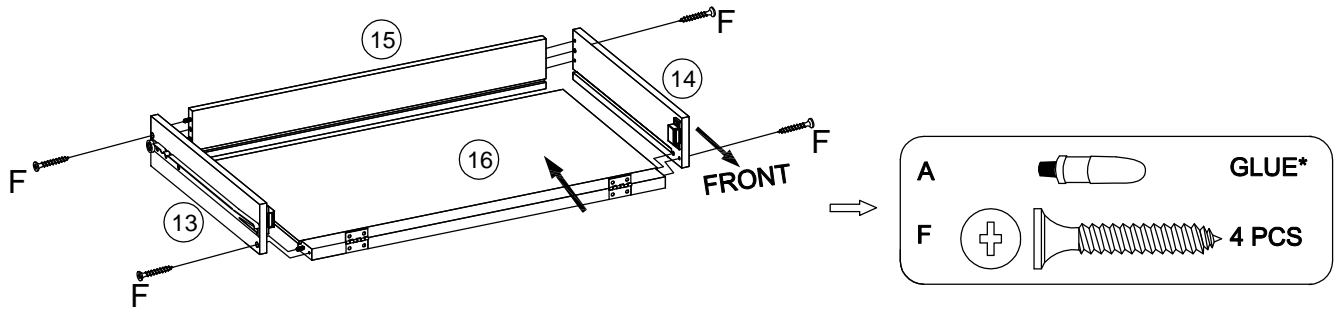

STEP 7

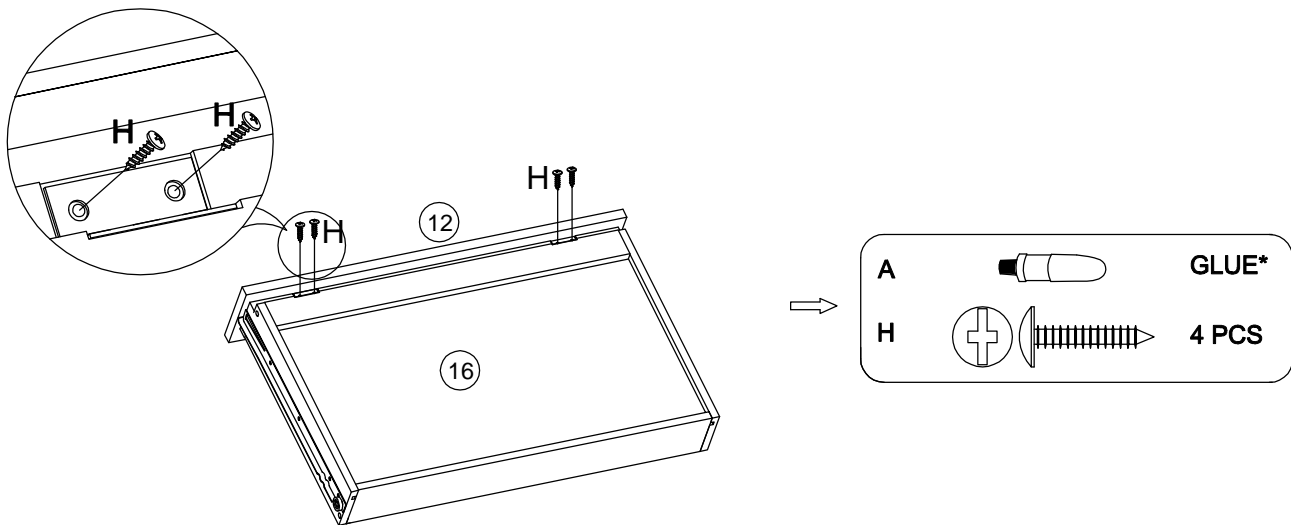

STEP 8

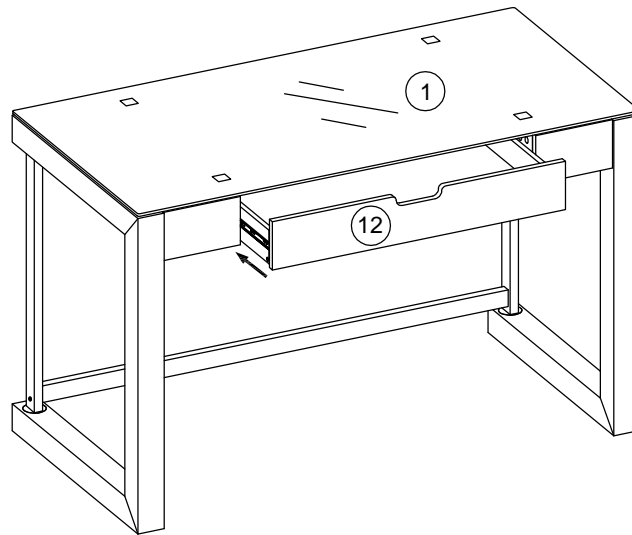

Carefully slide (12) Drawer Panel assemblies into place, using the Drawer Installation/Removal supplement below for reference.

Drawer Installation		Drawer Removal	
CORRECT 1 <p>Ball Bearing Plate FRONT</p>	INCORRECT 2 <p>Ball Bearing Plate FRONT</p>	3 <p>Black Nylon Clip FRONT</p>	4 <p>Black Nylon Clip FRONT</p>
<p>Before inserting the Drawer, make sure to slide the ball bearing plates located on the Side Frames to the FRONT of the unit as illustrated.</p>		<p>To release the glides, pull the Drawer out until you can see/feel the black nylon clips. Now press the clip on the Left Glide UPWARD while lifting the clip on the Right Glide DOWNWARD. This will release the Drawer to be easily removed.</p>	

STEP 9

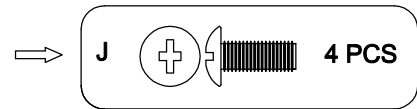
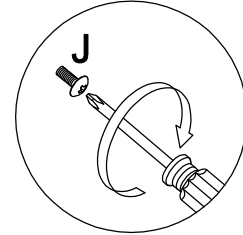
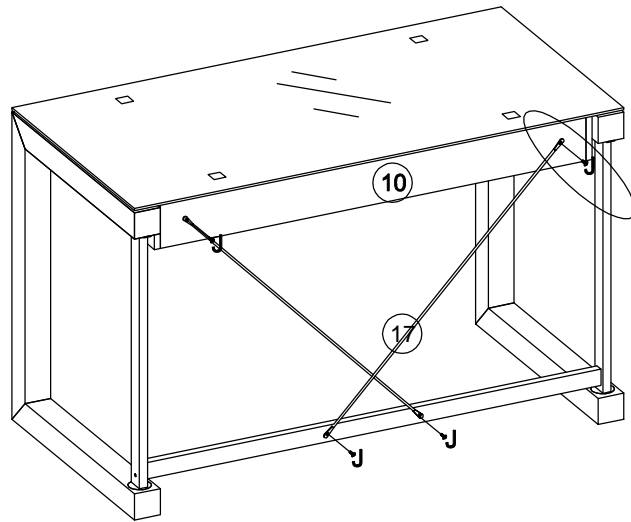

DIMENSIONS

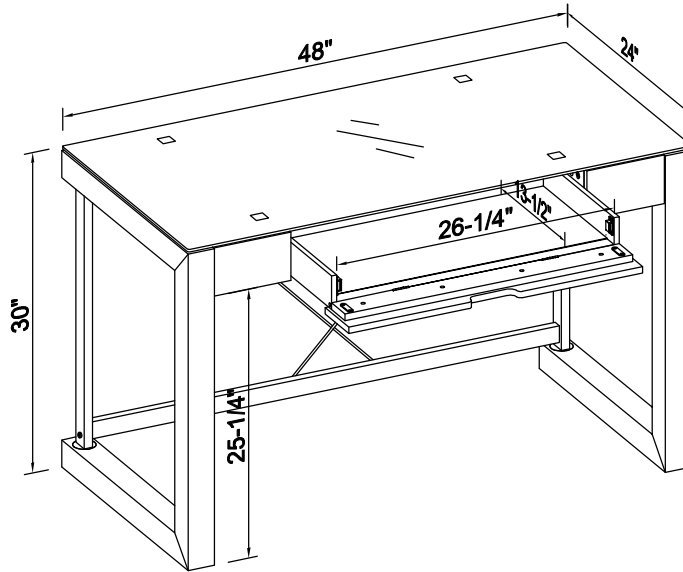

Product Size: 48"(W)x24"(D)x30"(H)

MAXIMUM WEIGHT CAPACITIES

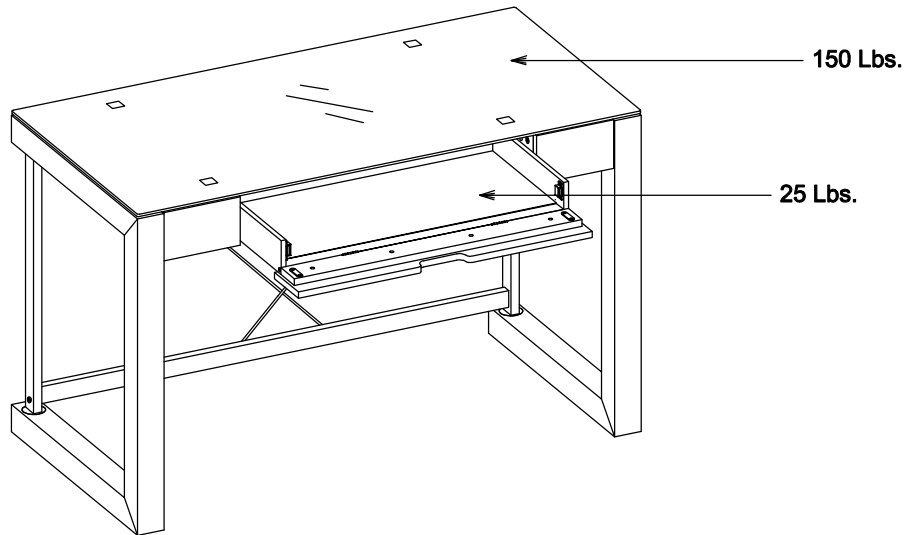

CAUTION: This product is intended to hold the Maximum Weight (EVENLY DISTRIBUTED) indicated. Exceeding the Maximum Weight will result in instability and may cause possible injury.



Creating beauty, Manufacturing great value!



One Year Limited Warranty

Thank you for purchasing a Z-Line Designs product. We promise to repair or replace any Z-Line Designs product or component that may have any defects in material or workmanship for as long as you, the original purchaser, own it. This warranty is subject to the provisions below. Z-Line Designs' sole obligation and purchasers' exclusive remedy pursuant to these warranties are limited to replacement at Z-Line Designs sole discretion. There are no other warranties except as expressly set forth below, either expressed or implied, including any warranty of merchantability for any particular purpose.

The word "defects" in this warranty is defined as imperfections that impair the service, function or effectiveness of the product.

ONE YEAR:

Glides, casters and user-adjustable work surface mechanisms, laminates, veneer finishes and other materials which cover your Z-Line Designs product.

INFORMATION ON COLOR VARIATIONS & FINISHES:

Some natural variations occurring in wood, or other natural materials are inherent to their character, and thus can not be avoided. Therefore they are not considered to be defects. Z-Line Designs does not warrant the color-fastness or matching of colors, grains, textures or other such materials. Customers' own materials selected by and used at the request of a user is therefore not warranted by Z-Line Designs.

LIMITATIONS INVOLVING MATERIALS & COMPONENTS:

The materials and all components listed below are covered according to the following schedule from the date of sale to the original purchaser.

EXCLUSIONS:

This warranty does not apply to: damage caused by the carrier, modifications to the product, or attachments to the product not approved by Z-Line Designs, non-standard materials selected by and used at the request of a user, and products that were not installed, used or maintained in accordance with product instructions and warnings. Nor shall Z-Line Designs have any responsibility for incidental or consequential damages resulting from the breach of this Warranty, including but not limited to inconvenience, rental or purchase of replacement products, loss of profits or commercial loss. Some states do not allow the exclusion or limitation of incidental or consequential damages so the above limitation or exclusion may not apply to you. This warranty gives you specific legal rights and you may also have other rights, which may vary from state to state. This warranty applies only to products sold within the United States of America and the Commonwealth of Canada.

TO OBTAIN SERVICE FROM THIS WARRANTY:

Your Z-Line Designs' dealer is our mutual partner in supporting your warranty requests. By following the procedures instructed below, you are assured that you will receive the best level of customer service guaranteed.

- A) Please contact the local Dealer from whom you originally purchased within 30 days (**unless otherwise noted by the Dealer**) of discovery of the defect. Prepare to confirm that you are the original purchaser of the product and provide necessary product information, such as serial number(s)/ UPC number(s) from the product in question.
- B) The Dealer will gather all the pertinent information required regarding your claim(s), inspect the product and thus contact a Z-Line Designs Customer Service Representative. (Please allow a reasonable amount of time for inspection, review, and response to Dealer.
- C) If the Z-Line Designs Dealer confirms that the product in review is eligible under the warranty conditions as stated above, the customer service representative or another representative of the Company will determine whether to provide replacement parts, or authorize other arrangements at the sole discretion of the vendor, Z-Line Designs. No assembly/labor is included in this warranty.

TO CONTACT CUSTOMER SERVICE:

Our knowledgeable Service Representatives are ready to assist you in the case this warranty applies to you. Please be prepared to explain the defect in detail, model/style number, date and location of purchase, your name, address, phone number and have your original sales receipt.

Please contact us Monday-Friday (except all major holidays) at:

Toll Free 1-888-736-2141 from 7:00 am - 3:30 pm (Pacific Standard Time) OR Email us: customerservice@z-linedesigns.com

OR

Contact your local dealer from whom you originally purchased the product in question.