

Monorail Power Jumper

700MOPJUMP_ 2.0



GENERAL PRODUCT INFORMATION:

This product is suitable for dry locations only.



This product must only be used with Tech Lighting MonoRail systems.

Measure the Distance Between the Monorail Sections

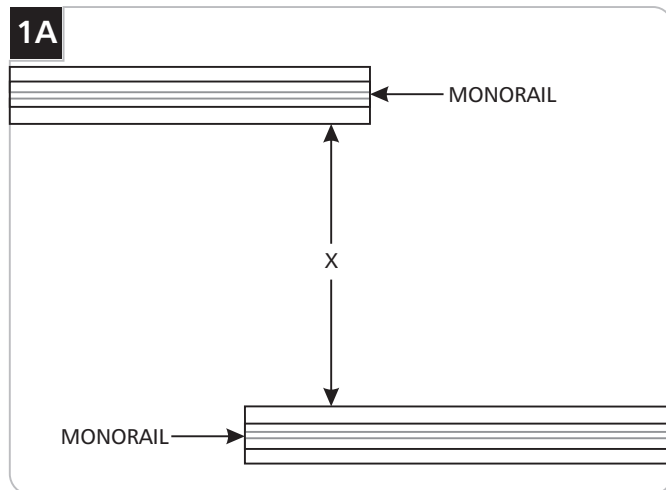

NOTE: The power jumper is not designed for distances greater than 36".

- 1 Install both sections of Monorail according to the instructions provided with the lighting system.
- 2 Measure the distance between the Monorail sections (X).
- 3a If distance X is exactly 36", continue to section 3 to install the power jumper.
- 3b If distance X is less than 36", write this distance down and continue to section 2 to cut the power jumper to the proper size. The power jumper is not designed for distances greater than 36".



Cut Down the Power Jumper

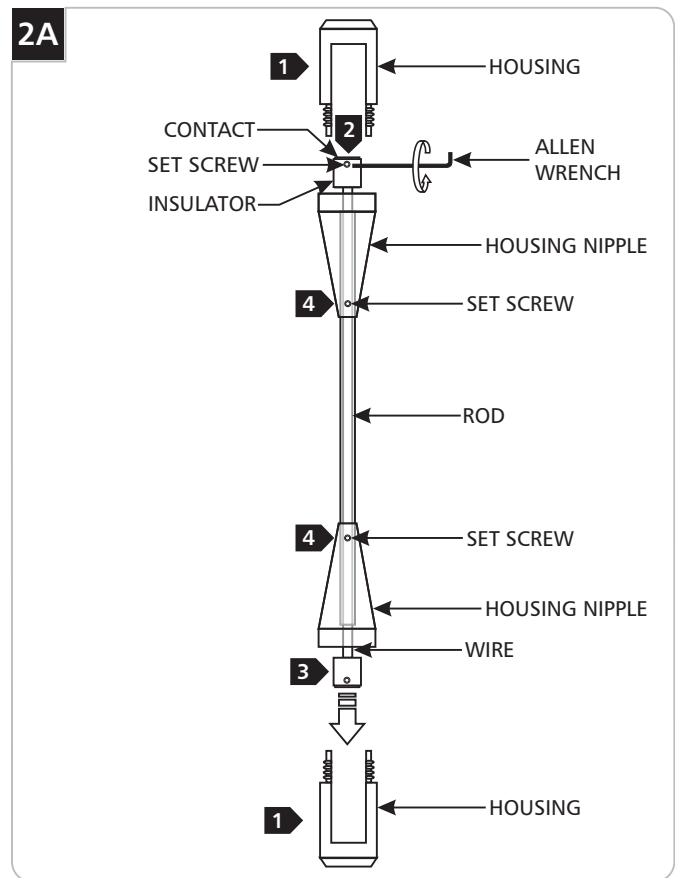

- 1 Unscrew the housings from both ends.
- 2 Loosen the set screw in one of the contacts, and remove the contact with insulator from the wire.
- 3 Pull on the other contact to get the wire out of the rod.
- 4 Loosen the set screw on the housing nipples and remove both nipples from the rod.

DISTANCE BETWEEN MONORAIL SECTIONS (X)	ROD LENGTH	WIRE LENGTH
36"	33-7/8"	35-3/8"
24"	21-7/8"	23-3/8"
12"	9-7/8"	11-3/8"
6"	3-7/8"	5-3/8"

For all other power jumper lengths:
 Cut the rod 2-1/8" shorter than X.
 Cut the wire 5/8" shorter than X.

- 5 Cut the rod to the desired length, and clean any burrs inside and outside the rod.
- 6 Cut the wire down to the desired length.
- 7 Strip exactly 3/16" of insulation from the end of the wire.

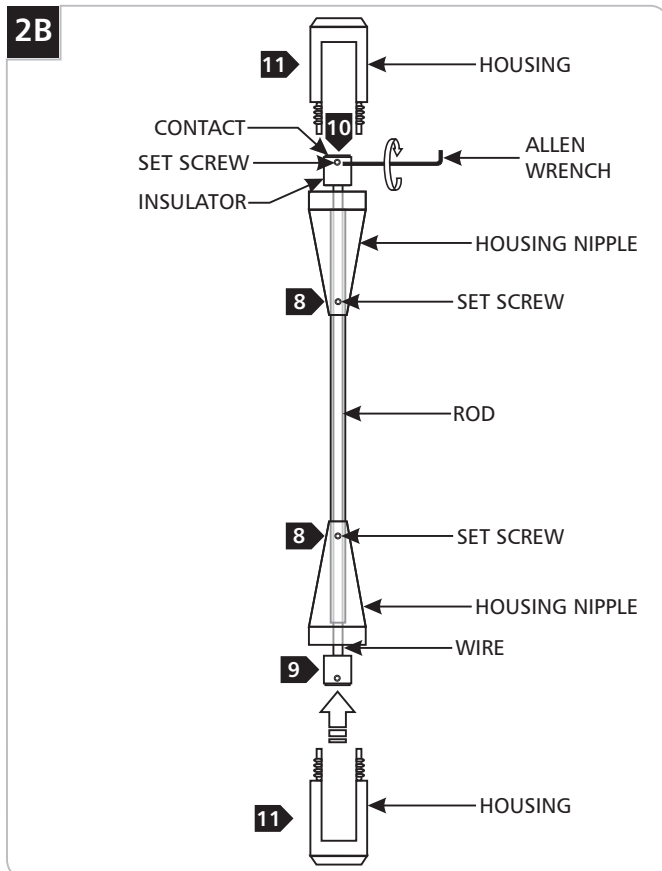

- 8 Place the housing nipples back on the rod.
- 9 Feed the wire back through one of the housing nipples.
- 10 Place the contact and insulator back onto the end of the wire and tighten the set screw.
- 11 Screw the housings back onto the housing nipples.

Connect the Monorail Sections

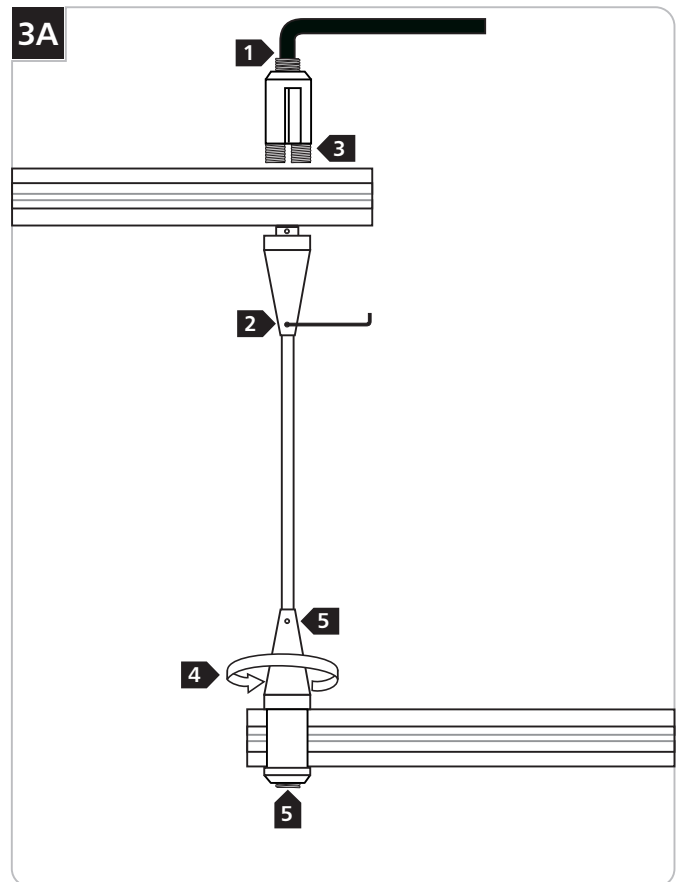

- 1 Back out the set screws on the end of each housing.
- 2 Loosen the small set screws in the housing nipples.
- 3 Slip a housing onto the MonoRail.
- 4 Turn the housing nipple to screw it to the housing.
- 5 Tighten the set screw on the housing nipple and at the end of the housing.
- 6 Repeat steps 3-5 for the other end of the power jumper.
- 7 To prevent heat build up and corrosion, make sure all the set screws are tight.

SAVE THESE INSTRUCTIONS!



7400 Linder Ave, Skokie, IL 60077
 847.410.4400

www.techlighting.com

© 2008 Tech Lighting, L.L.C. All rights reserved. The "Tech Lighting" graphic is a registered trademark of Tech Lighting, L.L.C. Tech Lighting reserves the right to change specifications for product improvements without notification.

A Generation Brands Company