

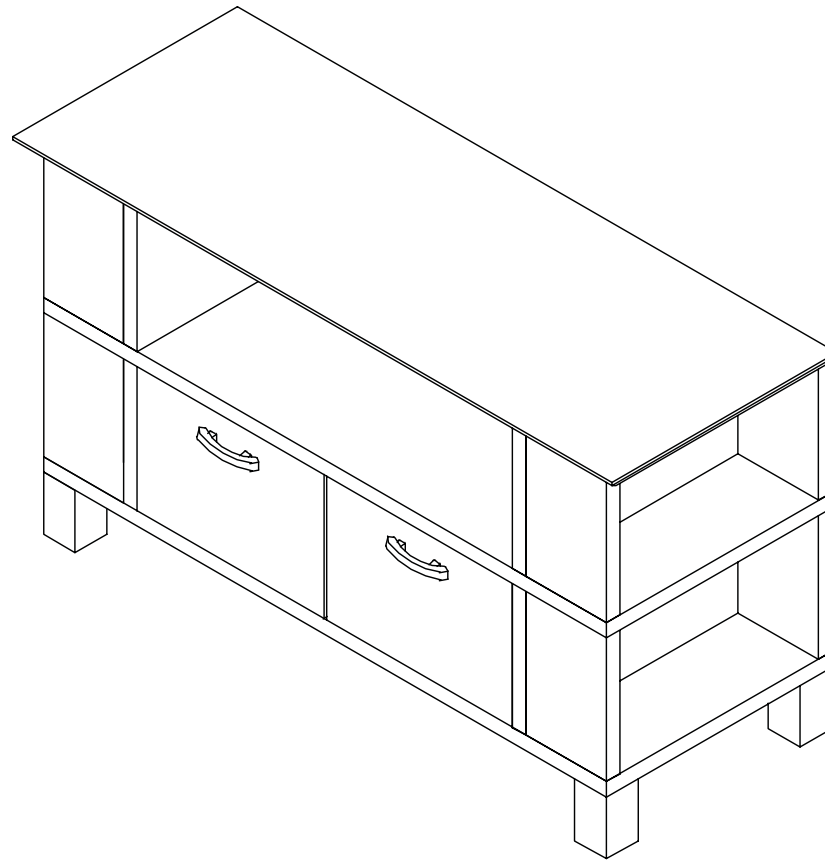

## **W44CMPBL, W44CMPMB ASSEMBLY INSTRUCTIONS**



For our most up-to-date instructions, to request missing, lost, or broken parts, or for any other Customer Service issues, please visit our website at [www.walkeredison.com](http://www.walkeredison.com) or call us at 1-877-207-5906.

## General Assembly Guidelines

- I. Ensure that all parts are available before beginning assembly.
- II. Follow each step carefully to ensure proper assembly of this product.
- III. The four (4) types of hardware used to assemble this TV console are: wood dowels, cam and bolt, hex-head bolts, and screws.
- IV. Two people are recommended for ease in assembly of this product.
- V. Power tools should not be used to assemble this product.
- VI. To attach wood dowels, place provided glue in the holes before inserting dowel.  
Wipe away excess glue immediately.

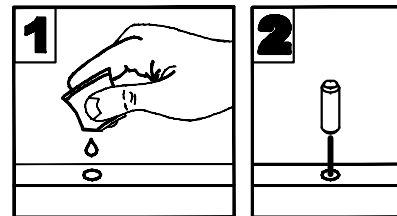
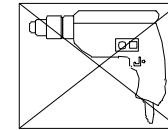





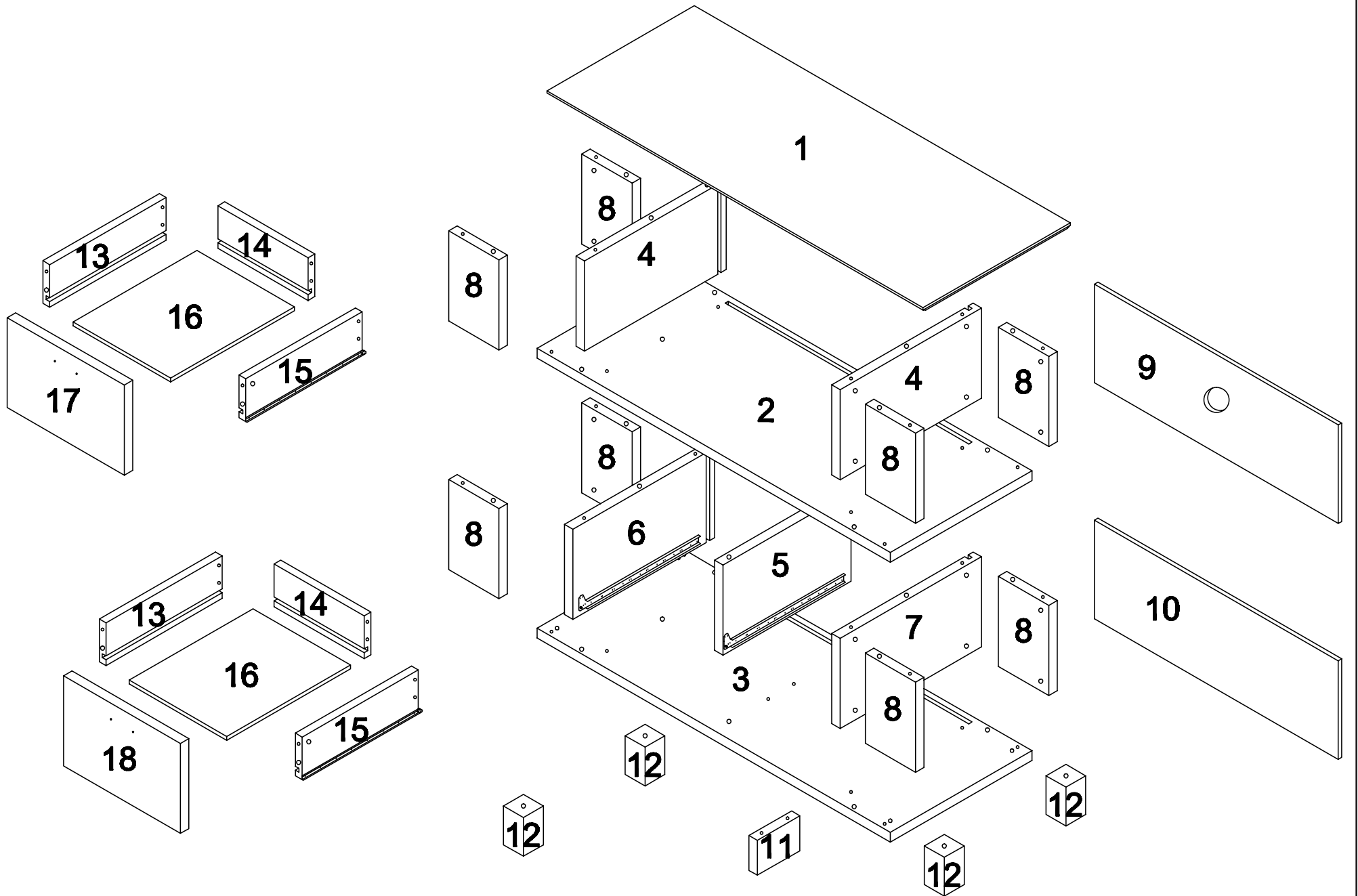



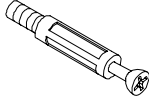
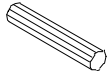

For our most up-to-date instructions, to request missing, lost, or broken parts, or for any other Customer Service issues, please visit our website at [www.walkeredison.com](http://www.walkeredison.com) or call us at 1-877-207-5906.

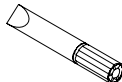
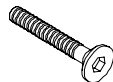
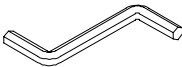
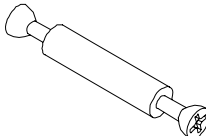
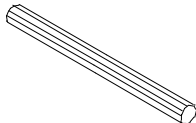
# W44CMPBL, W44CMPMB Parts List

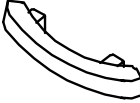

# W44CMPBL, W44CMPMB Hardware List

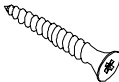
<b>A. Cam lock</b>		<b>32 pcs</b>
<b>A1. Cam lock</b>		<b>4 pcs</b>
<b>B. Cam bolt</b>		<b>20 pcs</b>
<b>C. Dowel</b>		<b>16 pcs</b>
<b>C1. Dowel</b>		<b>4 pcs</b>
<b>D. Glue tube</b>		<b>2 pcs</b>
<b>E. Screw (6x50mm)</b>		<b>6 pcs</b>
<b>F. Hex wrench</b>		<b>1 pc</b>
<b>H. Cam bolt</b>		<b>8 pcs</b>
<b>J. Dowel</b>		<b>6 pcs</b>

<b>N. Handle</b>		<b>2 pcs</b>
<b>P. Screw (4x22mm)</b>		<b>4 pcs</b>
<b>R. Plastic Wedges</b>		<b>8 pcs</b>
<b>S. Screw (3x14mm)</b>		<b>8 pcs</b>
<b>V. Screw</b>		<b>8 pcs</b>
<b>Sticker</b>		<b>36 pcs</b>

\* The hardware quantities listed are required for proper assembly.  
Some extra hardware may have also been included.

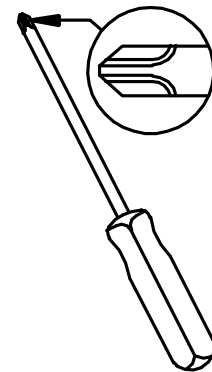

**Philips head screwdriver required for assembly  
(not included)**

## Step 1

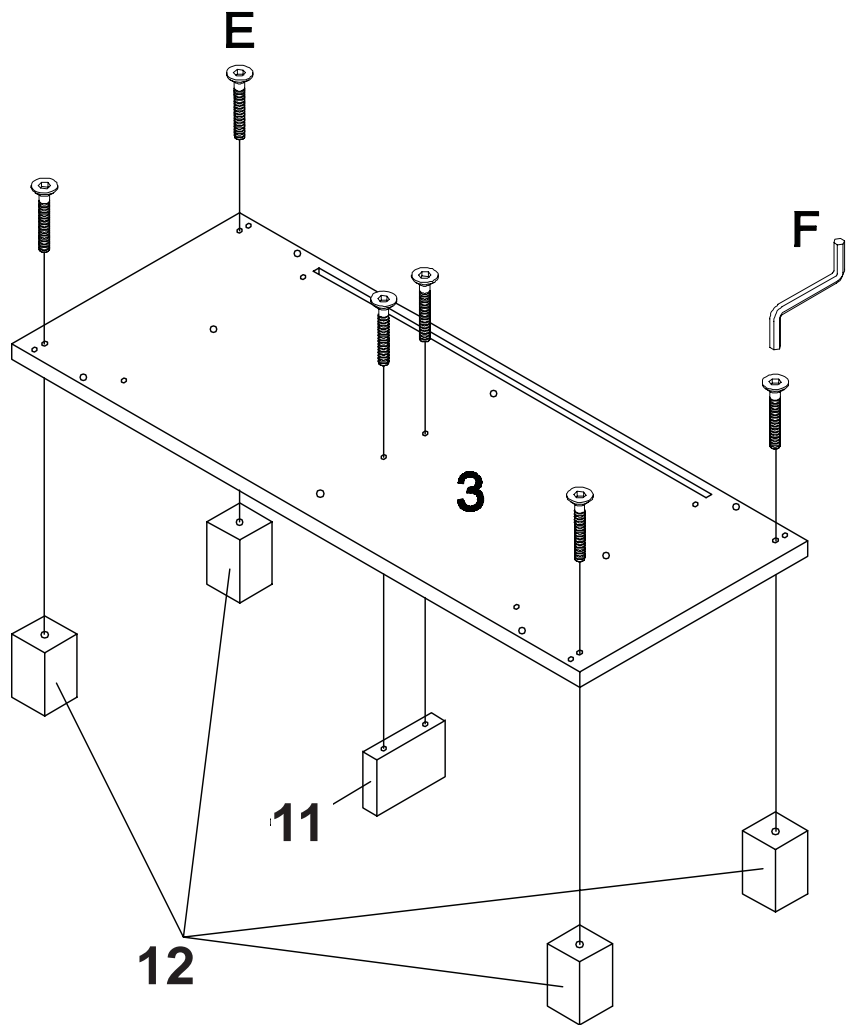

Attach feet (11 & 12) to the stand base (3) using screws (E) as shown in the illustration. Tighten screws firmly using the provided wrench (F).

## Step 2

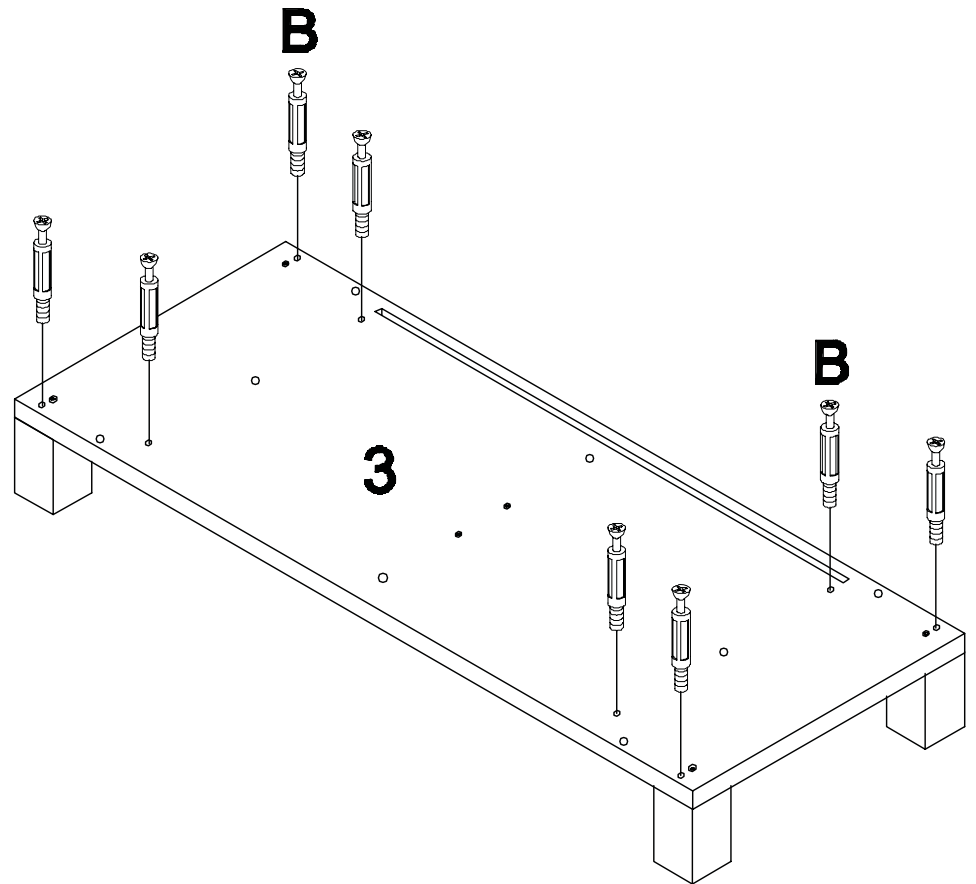

Screw cam bolts (B) into the stand base (3) as shown in the illustration. Be sure to tighten firmly.

### Step 3

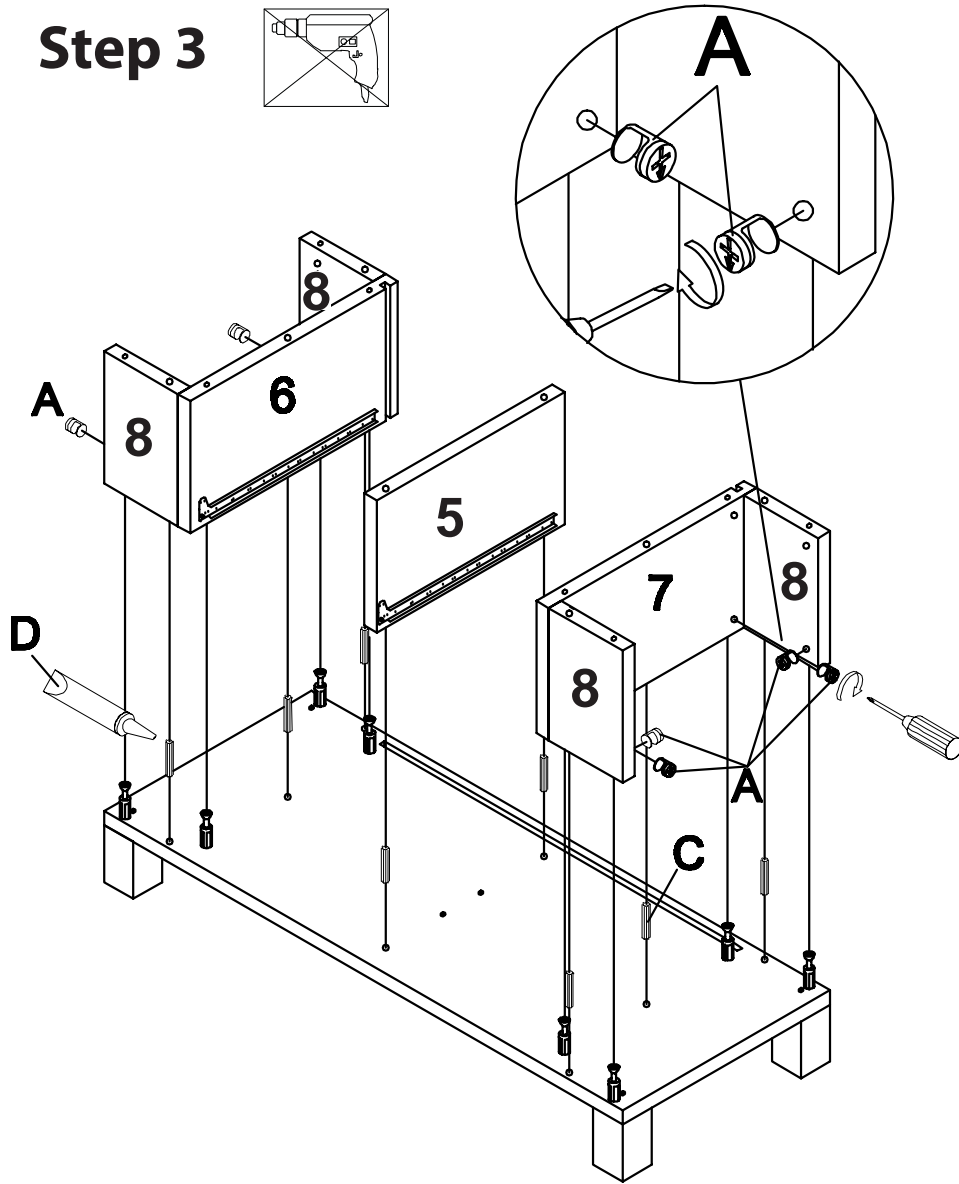
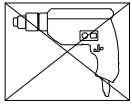

Insert dowels (C) into stand base.  
Apply glue (D) as directed in the "General Assembly Guidelines"  
Attach supports (5,6,7,8) to the base as shown in the diagram.  
Insert and tighten cam locks (A) as shown in the diagram.

### Step 4

**No vinyl lamination on this side**

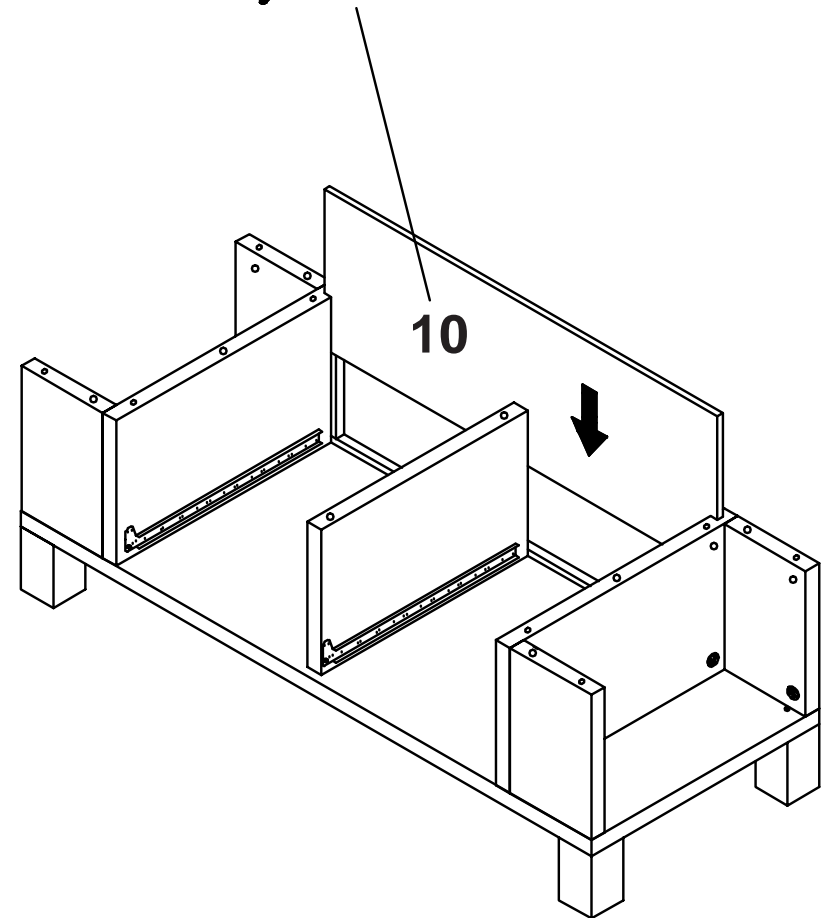

Slide lower back (10) into the grooves as shown in the diagram.  
Be sure that the side with no vinyl lamination is facing inward.

## Step 5

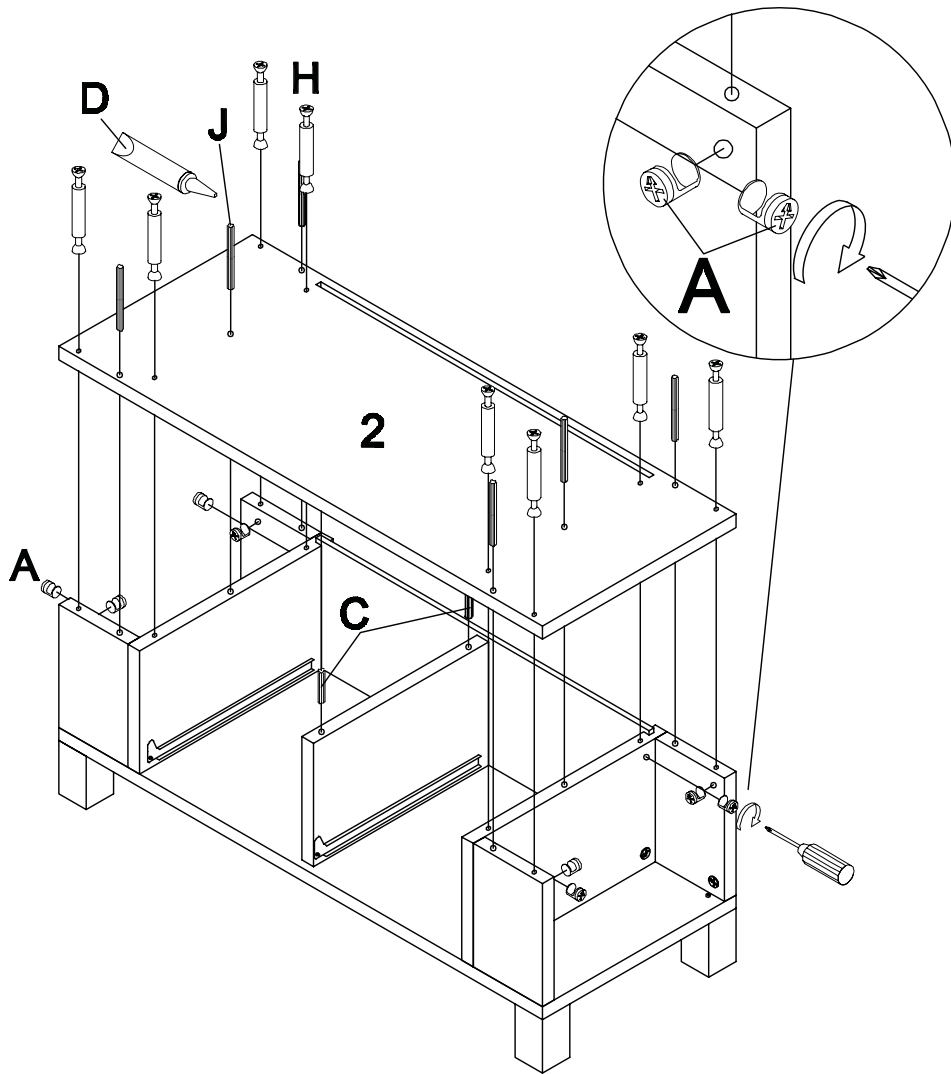
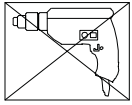

Insert dowels (C, J) and cam bolts (H) into the supports as shown in the diagram (*remember to apply glue (D) to dowels*). Slide panel (2) down over the dowels and cam bolts. **Parts H and J will pass through panel (2).** Insert and tighten cam locks (A) as shown in the diagram.

## Step 6

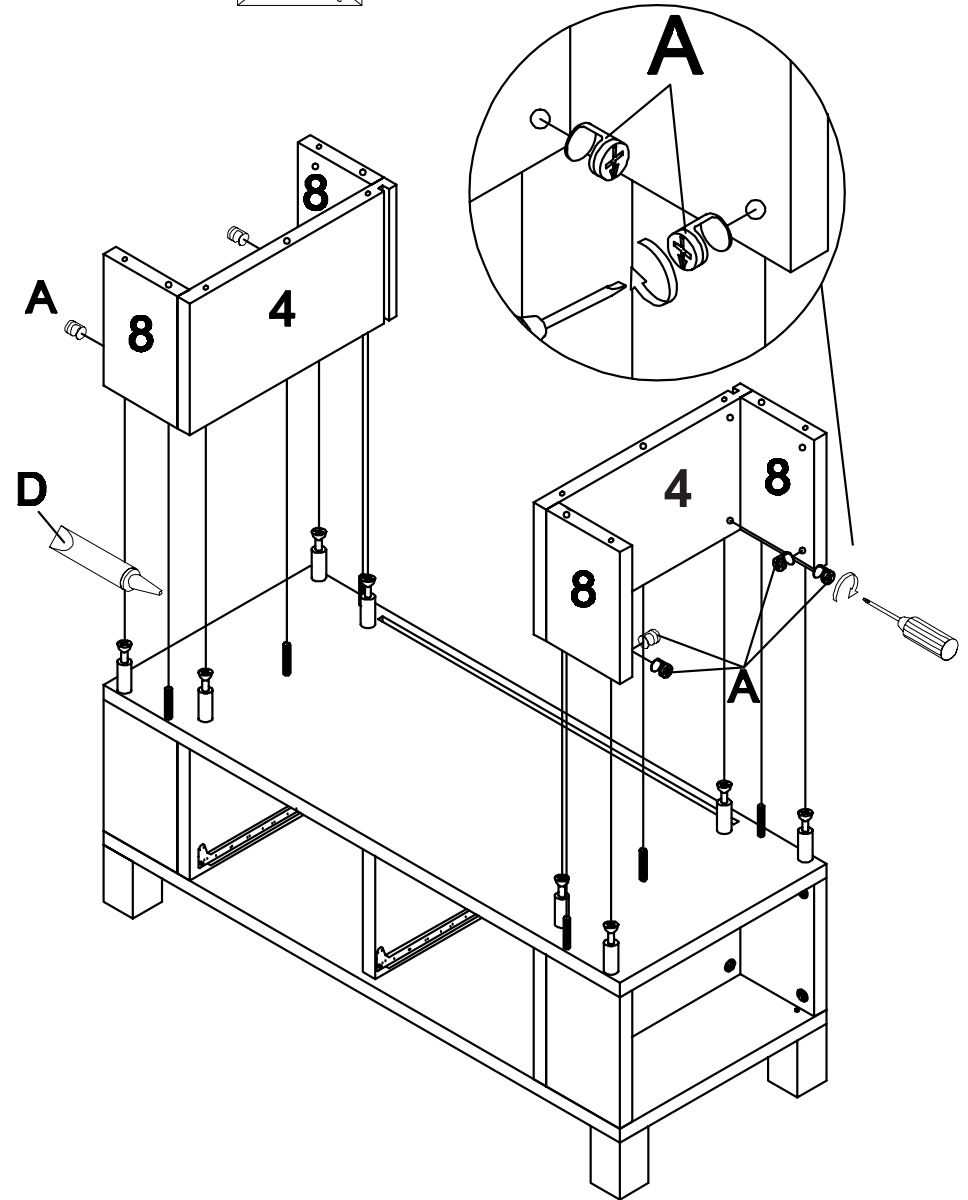
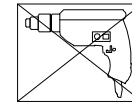

Attach supports (4, 8) to the panel as shown in the diagram. Insert and tighten cam locks (A) as shown in the diagram. (*Remember to apply glue (D) to dowels*)

## Step 7

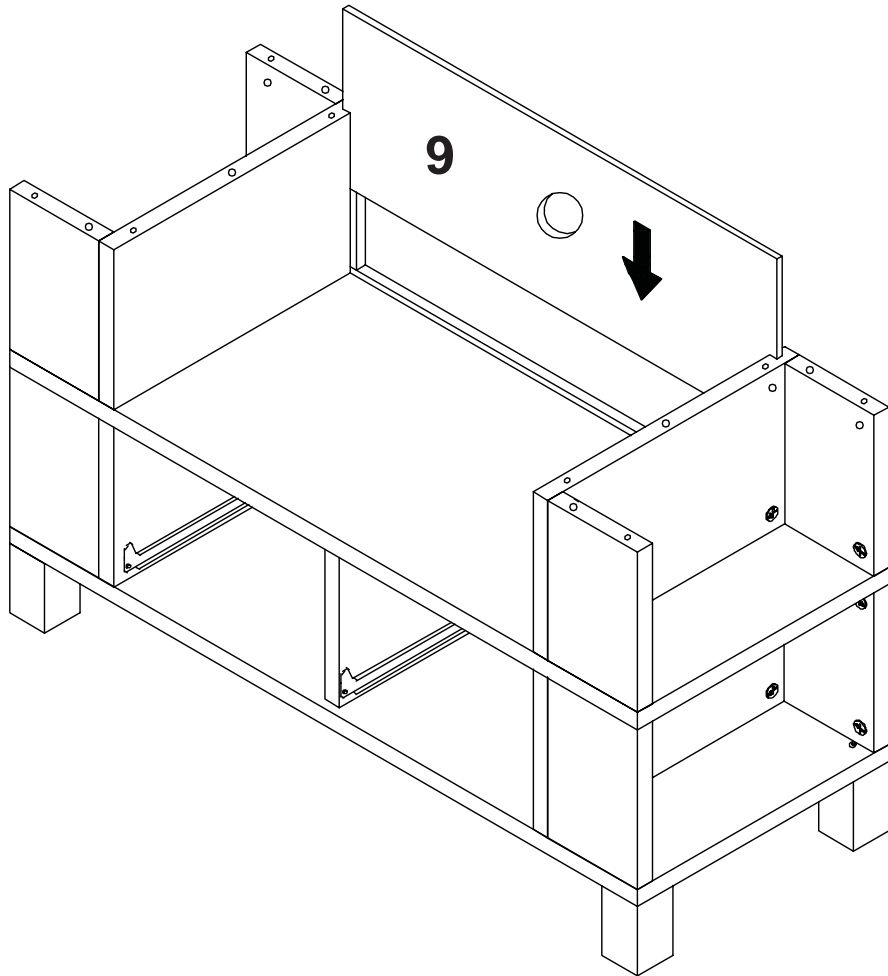

Slide upper back panel (9) into the grooves as shown in the diagram.  
*Ensure the warning label is on the back side.*

## Step 8

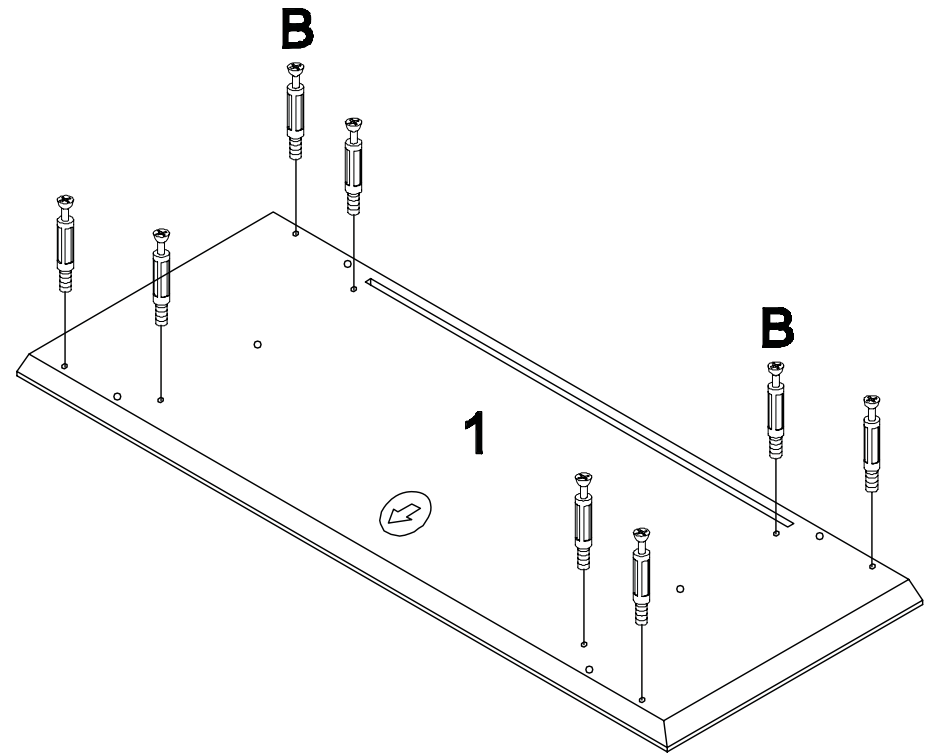

Screw cam bolts (B) into the stand top (1) as shown in the illustration.  
Be sure to tighten firmly.



## Step 9

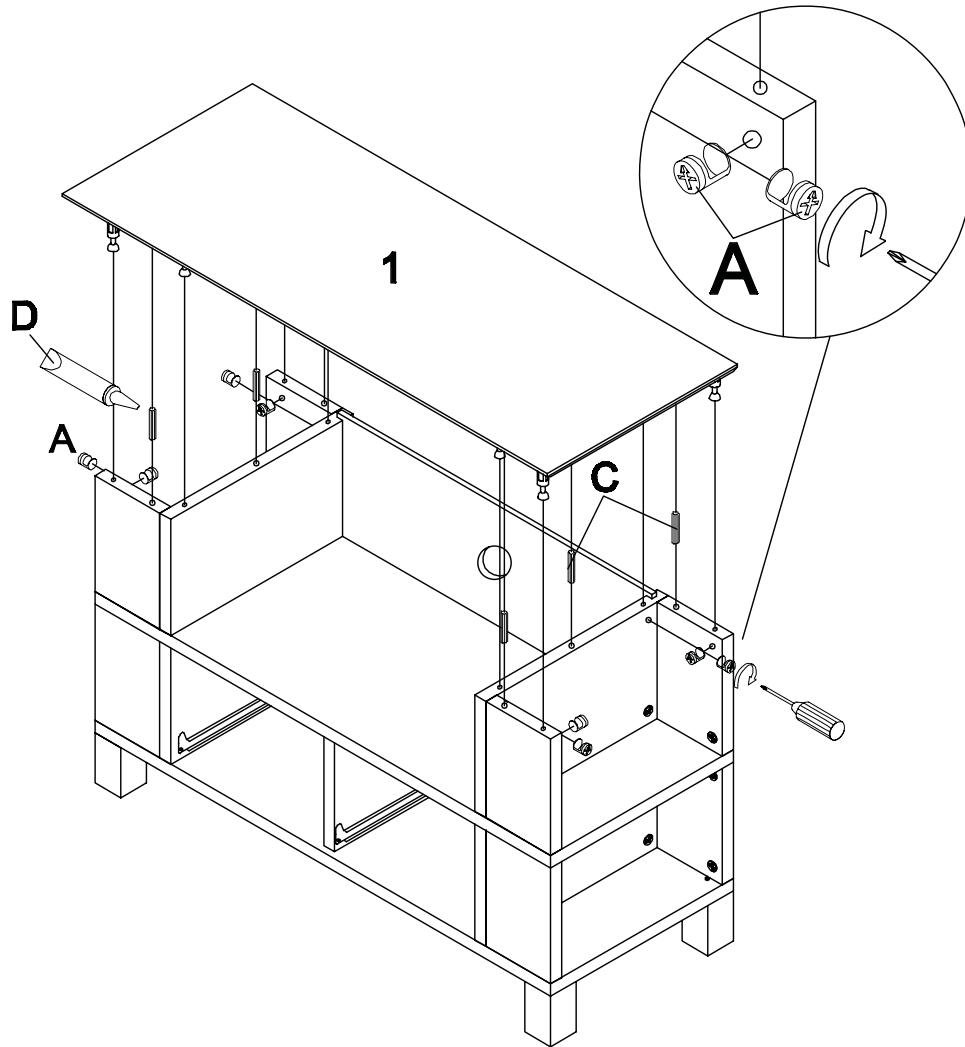
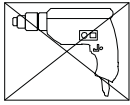

Insert dowels (C) into the supports as shown in the diagram (*remember to apply glue (D) to dowels*). Place stand top (1) into position as shown in the diagram. Insert and tighten cam locks (A) as shown in the diagram.

## Step 10

**Sticker X 32**

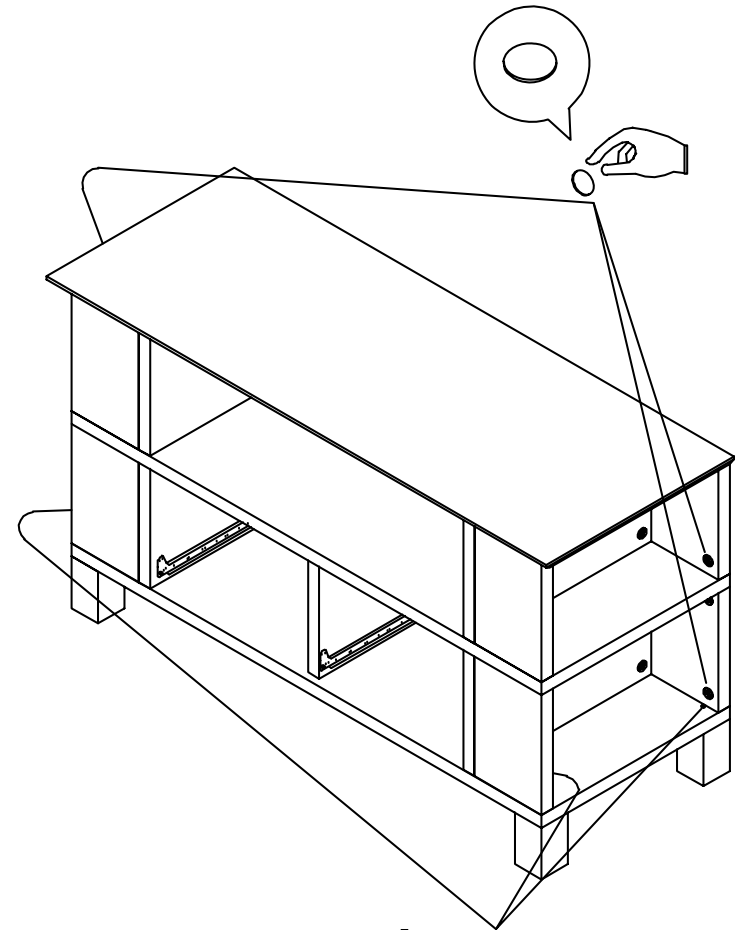

**Sticker X 4**

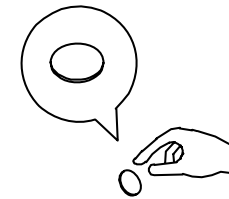

Ensure that all cam locks (A) have been tightened. Place stickers over visible cam locks as shown in the diagram.

# Step 11

\*Step 11 has been broken into smaller steps to aid in the assembly of the drawers.

a.

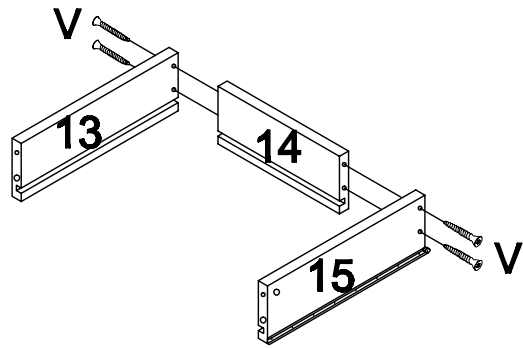

b.

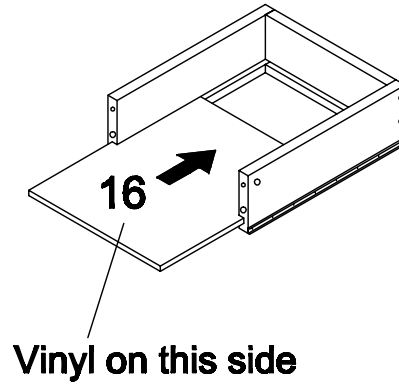

c.

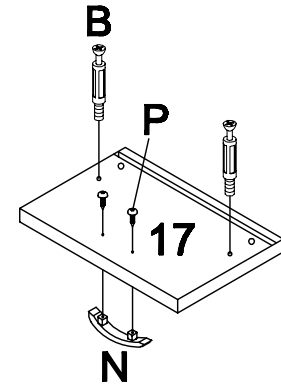

d.

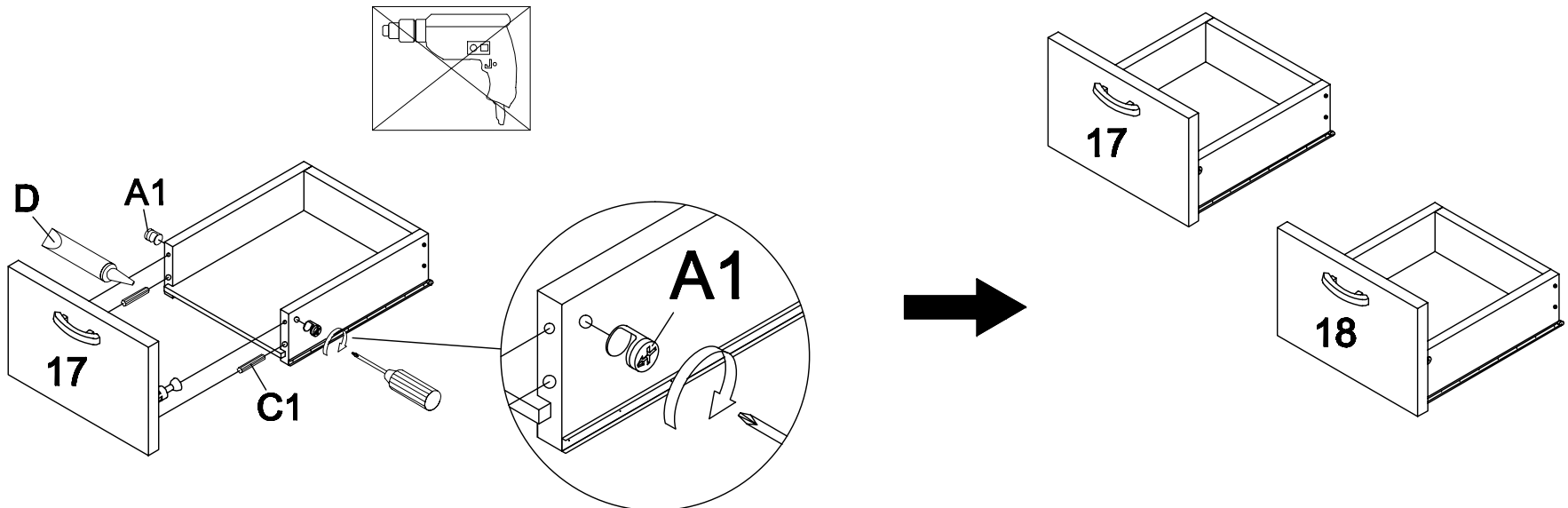

- Attach drawer panels (13, 14, 15) together using screws (V) (be sure to tighten firmly).
- Slide drawer bottoms (16) into the assembled drawer panels as shown in the diagram.
- Attach handles (N) to the drawers fronts (17, 18) using screws (P), then screw cam bolts (B) into drawer fronts.
- Insert dowels (C1) into drawer fronts as shown in the diagram (remember to apply glue (D) to dowels). Join drawer fronts to the drawer panels. Insert and tighten cam locks (A1) as shown in the diagram.

## Step 12

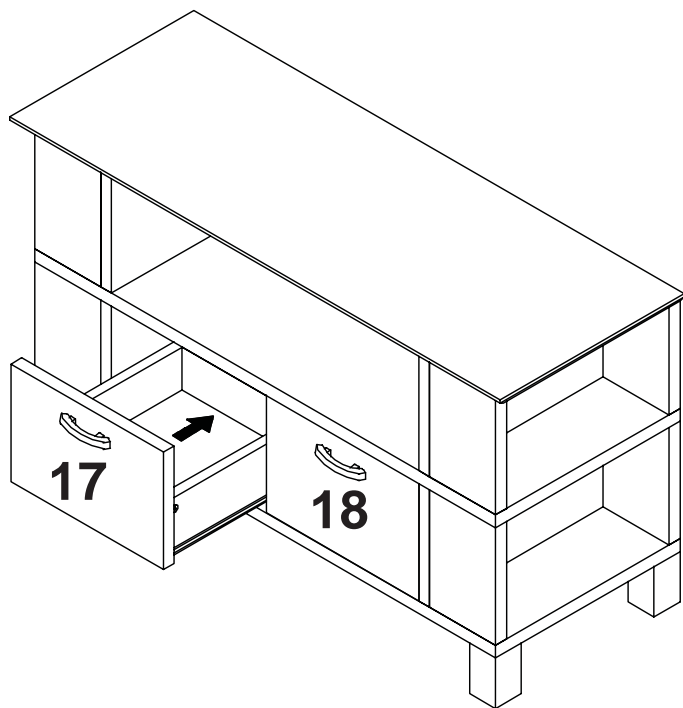

Slide assembled drawers (17, 18) carefully into place as shown in the diagram.

## Step 13

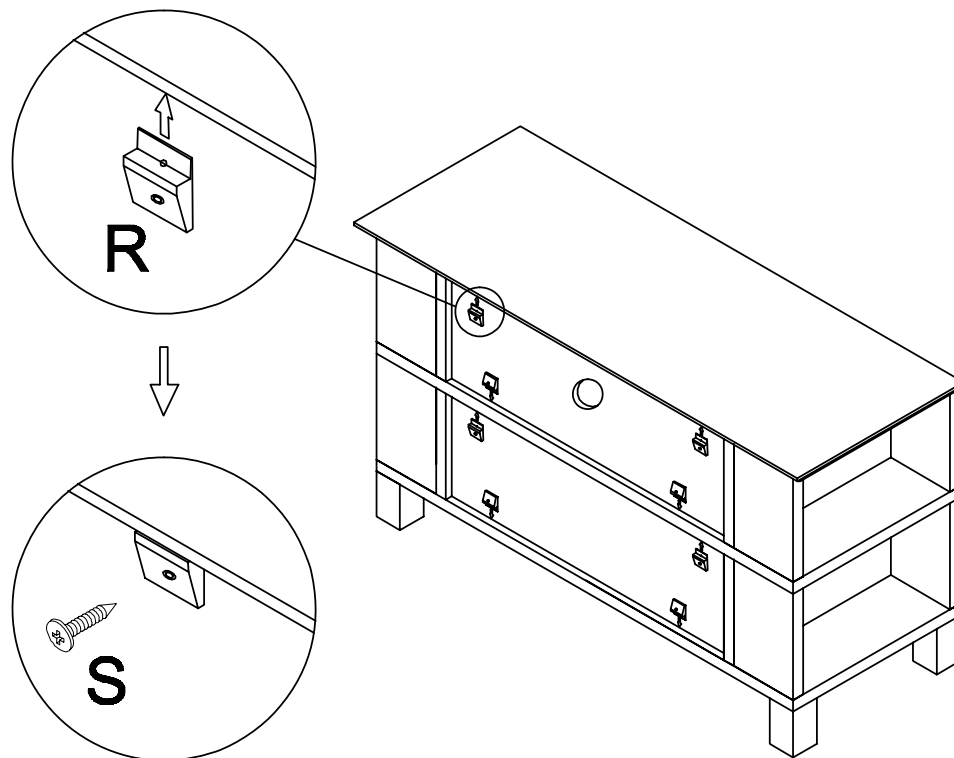

**BACK SIDE**

Insert plastic wedges (R) between the stand frame and the back panels as shown in the diagram. Fasten plastic wedges to the back panel using screws (S).