

Assembly Diagram

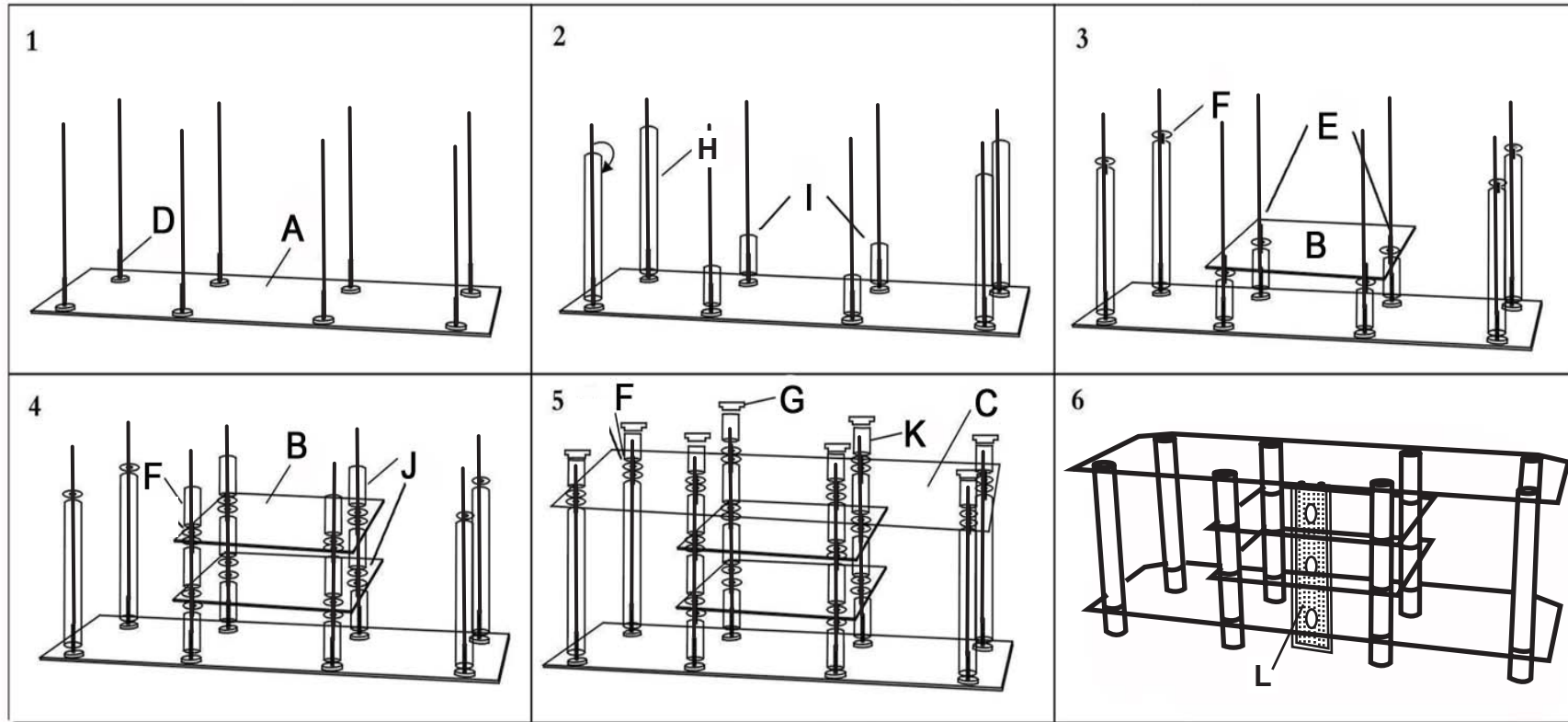

Model No: V60Y712, V60Y712B, V60Y712CB



A	Top Glass		1	F	Decorative Rings		32	J	6" Cylinder		8
B	Middle Glass		3	G	Caps Attached to (K)		8	K	3" Cylinder		8
C	Bottom Glass		1	H	19" Cylinder		4	L	Cable Mgmt		1
D	Rods		8	I	7" Cylinder		4	M	Rods & Nuts		2
E	Wrench		1								

****NOTE:** Some parts may come pre-assembled for shipping purposes and will need to be dis-assembled for assembly. Extra parts have also been included. Both black (B) and clear black (CB) models come with both chrome and black rings sets ("c")

Assembly Instructions

V60Y712, B, CB

*Important: Make sure all parts are available for assembly
Follow instructions steps very carefully*

NOTES: The middle leg assembly may be pre-assembled. Please unscrew each of the medium sized cylinders before assembling this stand.
Be sure flat side of ring is facing the glass and the cylinder is inserted into the cupped side of the ring (see "Additional Info" page)

Step 1: Lay glass "A" upside down on a soft surface
Screw rods "D" on all plates and tighten firmly.

Step 2: Place long cylinders "H" on all four rods "D"
Place four 7" cylinders "I" on the four middle plates

Step 3: Place rings "F" on all cylinders (See "NOTES")
Place carefully the middle glass "B" on all four middle rods
Place rings "F" on all four middle rods

Step 4: Place four 6" cylinders "J" on the middle screws ("E")
Place rings "F" on all middle cylinders "J"
Place glass "B" on the middle rods
Place rings "F" on all middle rods
Screw four 6" cylinders "J" on the middle rods

Step 5: Place rings "F" on all middle rods
Place "C" glass carefully on all of the cylinders. (Be sure it is pushed all the way down)
Place rings "F" on all rods
Screw all short cylinders "K" on all the rods
Put caps "G" on all cylinders to protect from scratching the floor

Step 6: Attach Cable Management (L) with Rods and Nuts (M)

Step 7: Turn over very carefully and slowly



For our most up to date instruction, to request missing, lost, or broken parts, or for any other Customer Service issues, please visit our website at www.walkerredison.com or call us at 877-207-5906.



Additional Info

While assembling your stand, please note that the decorative rings require correct placement on the cylinders for the stand to fit together properly.

Each decorative ring has a flat side and a cupped side.

The flat side of the ring must always face toward the glass.

The cupped side of the ring must always face toward the cylinder and be seated completely against the cylinder.

For our most up to date instruction, to request missing, lost, or broken parts, or for any other Customer Service issues, please visit our website at www.walkerredison.com or call us at 877-207-5906.

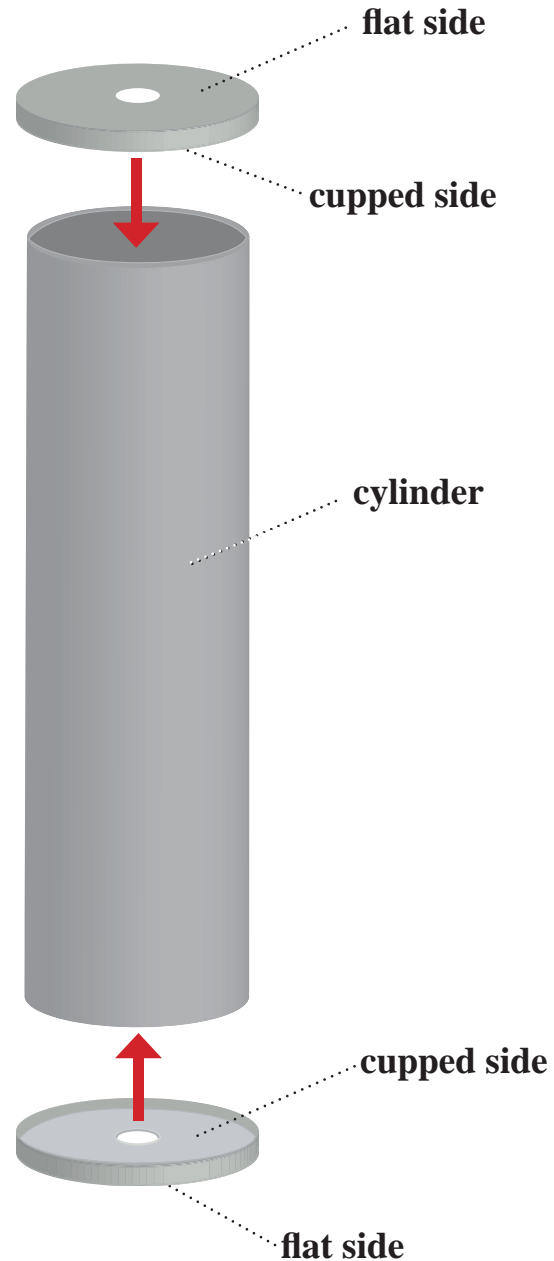

finished cylinder assembly

