

Assembly Instructions

V35CMP, V35CMPB, V35CMPCB

*Important: Make sure all parts are available for assembly
Follow instruction steps very carefully*

This component stand comes with 3", 5", 6", 8", and 9" leg cylinders.

To customize the stand or shelf height, you can interchange leg cylinders or exclude legs and glass for a shorter component stand. The instructions below are for a recommended shelf spacing. Again, remember that you can interchange the leg sizes for varying shelf height as you choose.

Step 1: Lay glass "A" upside down on a soft surface
Screw "H" in all four plates

Step 2: Screw cylinder "F" in all four screws "H" (Tighten firmly)
Fasten screws "I" in all four cylinders "F"
Place rings "J" on all cylinders "F"
Place glass "B" on all screws "I"
Place rings "J" on all cylinders "F"
Screw cylinder "E" in all four screws "I" (Tighten firmly)

Step 3: Fasten screws "I" in all four cylinders "E"
Place rings "J" on all cylinders "E"
Place glass "B" on all screws "I"
Place rings "J" on all cylinders "E"
Screw cylinder "C" in all five screws "I" (Tighten firmly)
Fasten screws "I" in all four cylinders "C"
Place rings "J" on all cylinders "C"
Place glass "B" on all screws "I"

Step 4: Place rings "J" on all cylinders "I"
Screw cylinder "D" in all five screws "I" (Tighten firmly)
Fasten screws "I" in all four cylinders "D"
Place rings "J" on all cylinders "D"
Place glass "B" on all screws "I"
Place rings "J" on all cylinders "D"
Screw cylinder "G" in all five screws "I" (Tighten firmly)
Place caps "K" on all cylinders "G"

Step 5: Turn upright very carefully



For our most up to date instruction, to request missing, lost, or broken parts, or for any other Customer Service issues, please visit our website at www.walkerredison.com or call us at 877-207-5906.

Assembly Diagram

Model No: V35CMP, V35CMPB, V35CMPCB

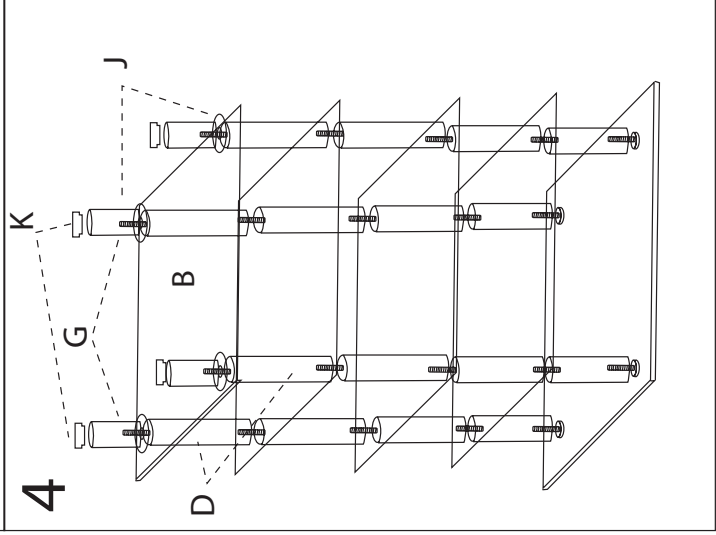
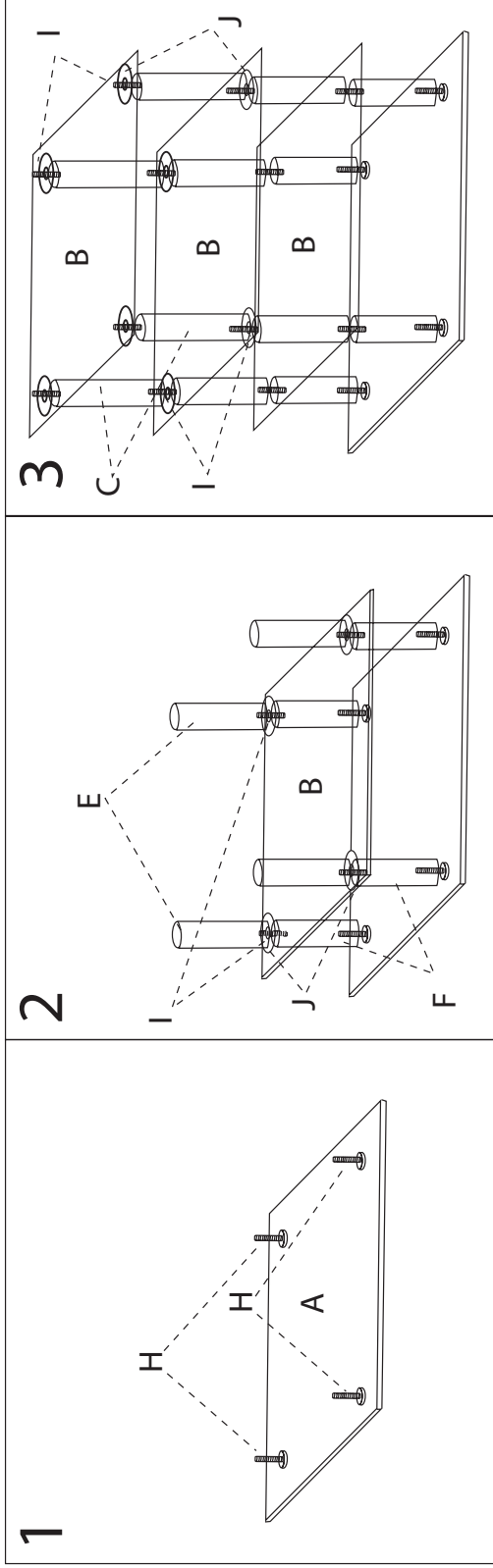

A	Top Glass		1
B	Glass Shelves		4
C	9" Cylinders		4
D	8" Cylinders		4
E	6" Cylinders		4
F	5" Cylinders		4
G	3" Cylinders		4
H	1 1/2" Screws		4
I	2" Screws		16
J	Trim Rings		32
K	Rubber Feet		4

**Note: Some parts may come pre-assembled for shipping purposes and must be dis-assembled for assembly. Some extra parts have also been included. Black and Clear Black models come with both chrome and black trim ring sets.



Additional Info

While assembling your stand, please note that the decorative rings require correct placement on the cylinders for the stand to fit together properly.

Each decorative ring has a flat side and a cupped side.

The flat side of the ring must always face toward the glass.

The cupped side of the ring must always face toward the cylinder and be seated completely against the cylinder.

For our most up to date instruction, to request missing, lost, or broken parts, or for any other Customer Service issues, please visit our website at www.walkerredison.com or call us at 877-207-5906.

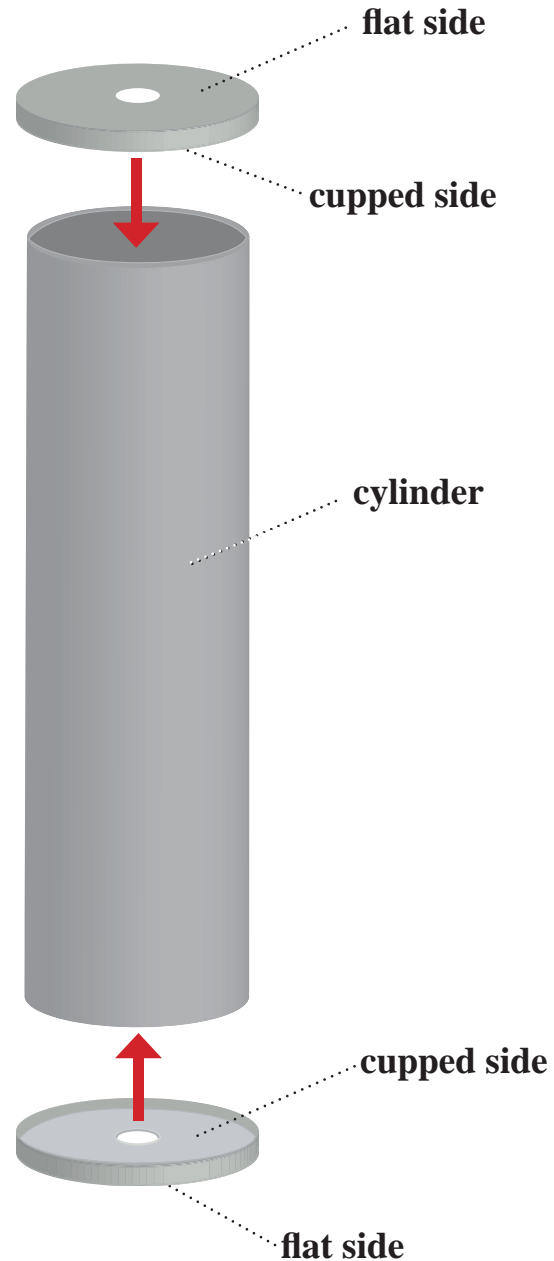

finished cylinder assembly

