

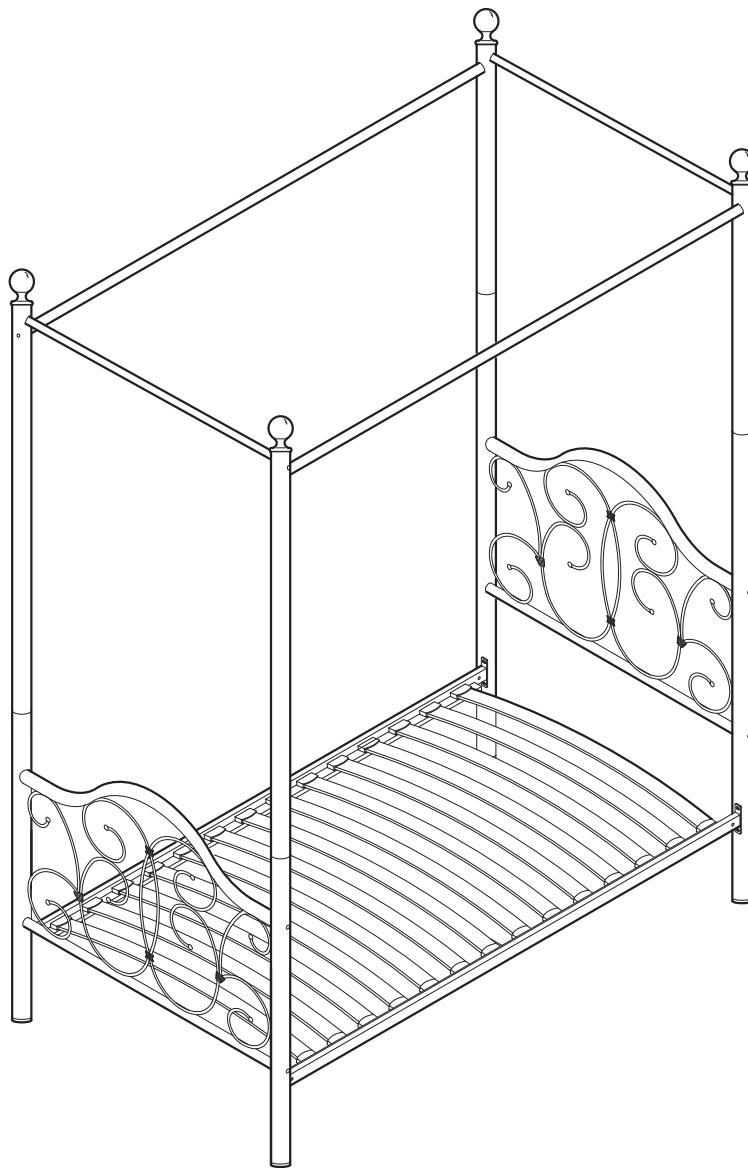

Walker  
Edison

furniture company

Item #: BT40CP  
Assembly Instructions









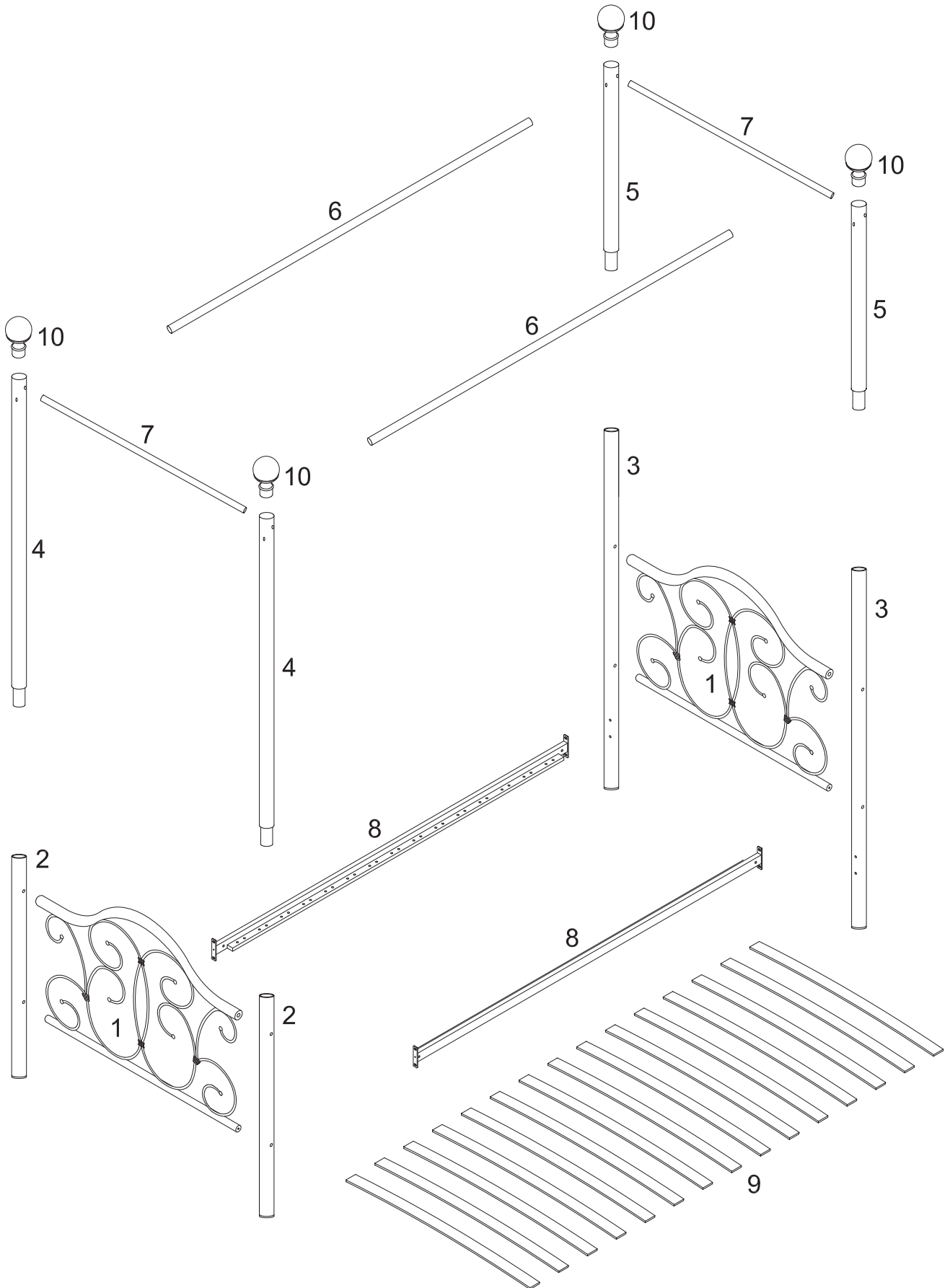

*For our most current instructions, to request missing, lost or broken parts, or for any other Customer Service issues, please visit our website at [www.walkeredison.com](http://www.walkeredison.com) or call us at 877-207-5906.*

Revised 01/2012

# Parts List



# Hardware List

A		Ø1/4" * 1"	Bolt	8 pcs
B		Ø1/4" * 2-1/4"	Bolt	16 pcs
C		Ø16mm	Washer	8 pcs
D		Ø24mm	Washer	8 pcs
E		Ø1/4" * 1/2"	Bolt	4 pcs
F			Washer	16 pcs
G			End cap	30 pcs
H		M4mm	Wrench	1 pc

*The hardware quantities listed above are required for proper assembly.  
Some extra hardware may also have been included.*

# Assembly Options

## Option A

To build this option, follow Steps 1-6 then Steps 7A-10A.

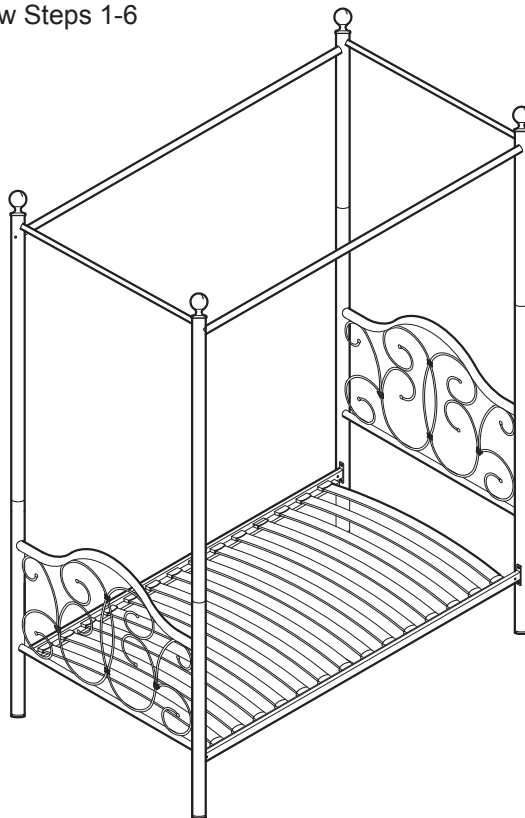

## Option B

To build this option, follow Steps 1-6 then Steps 7B-8B.

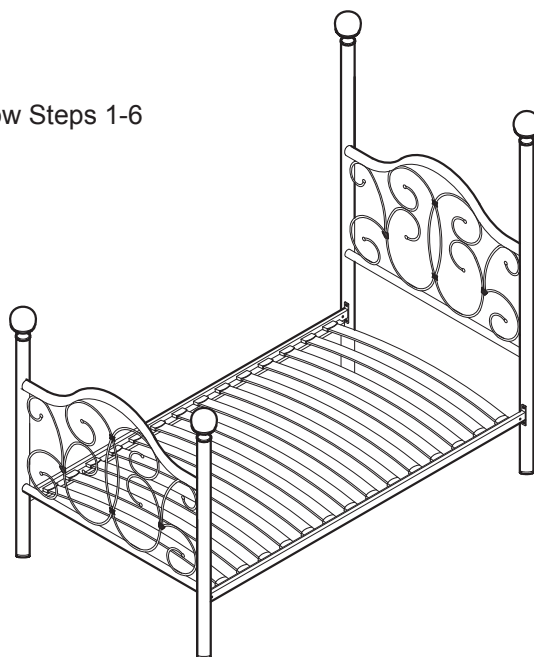

# Step 1

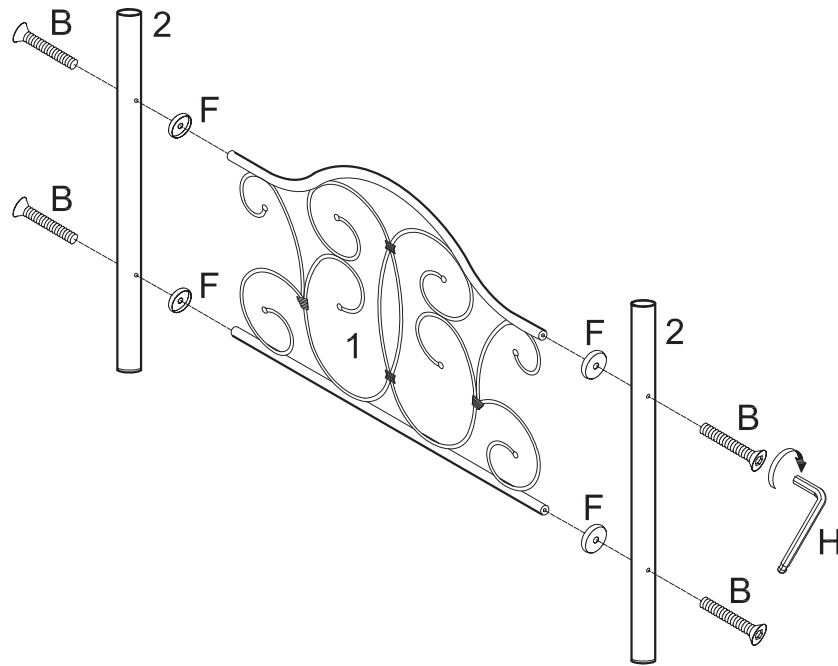

Attach decorative piece (1) to legs (2) using bolts (B) and washers (F). Washers (F) will fit onto the ends of decorative piece (1). Tighten bolts (B) with wrench (H).

# Step 2

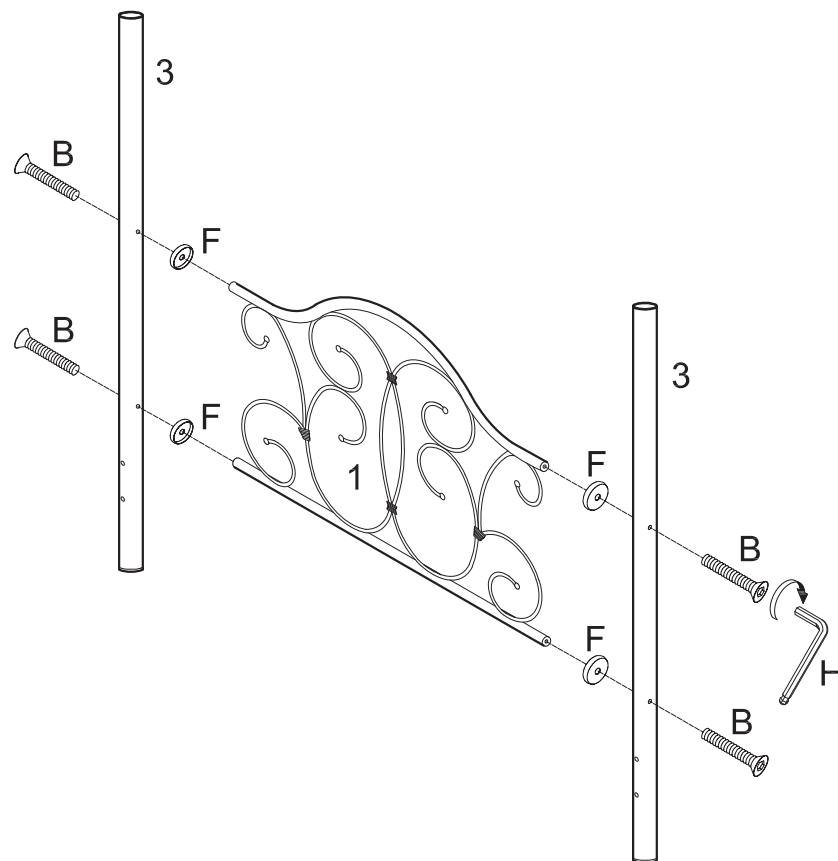

Attach decorative piece (1) to legs (3) using bolts (B) and washers (F). Washers (F) will fit onto the ends of decorative piece (1). Tighten bolts (B) with wrench (H).

## Step 3

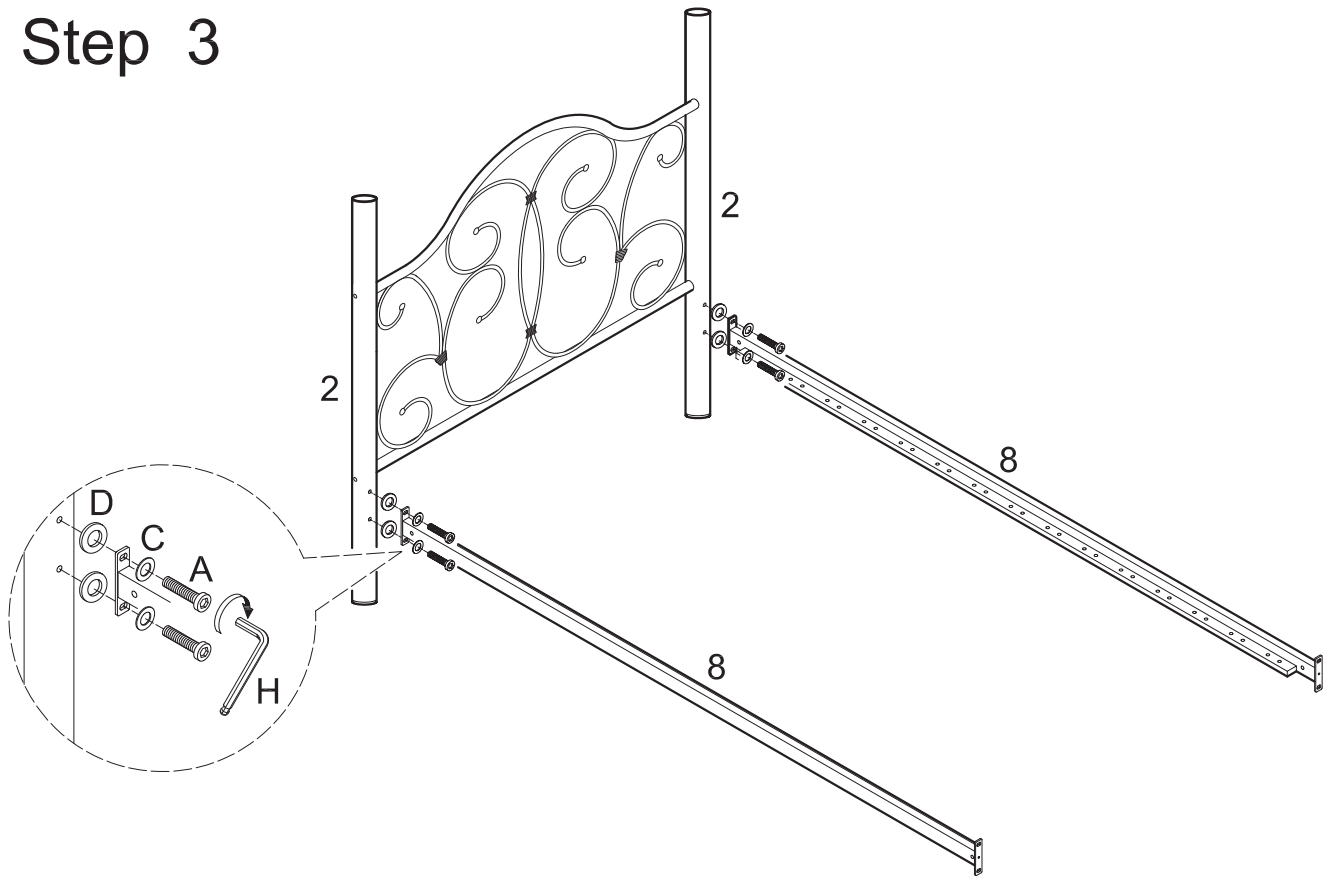

Attach crossbars (8) to legs (2) using bolts (A) and washers (C,D). Tighten bolts (A) with wrench (H).

## Step 4

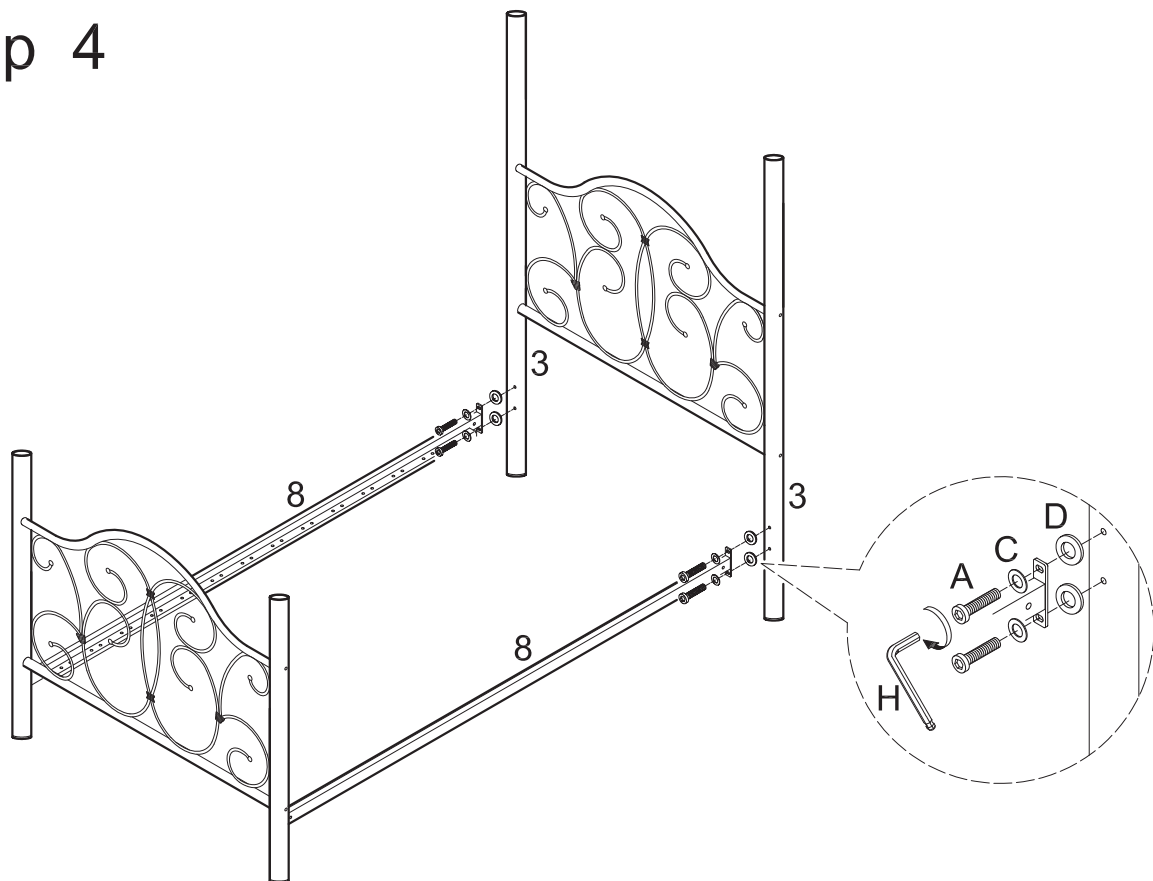

Attach crossbars (8) to legs (3) using bolts (A) and washers (C,D). Tighten bolts (A) with wrench (H).

## Step 5

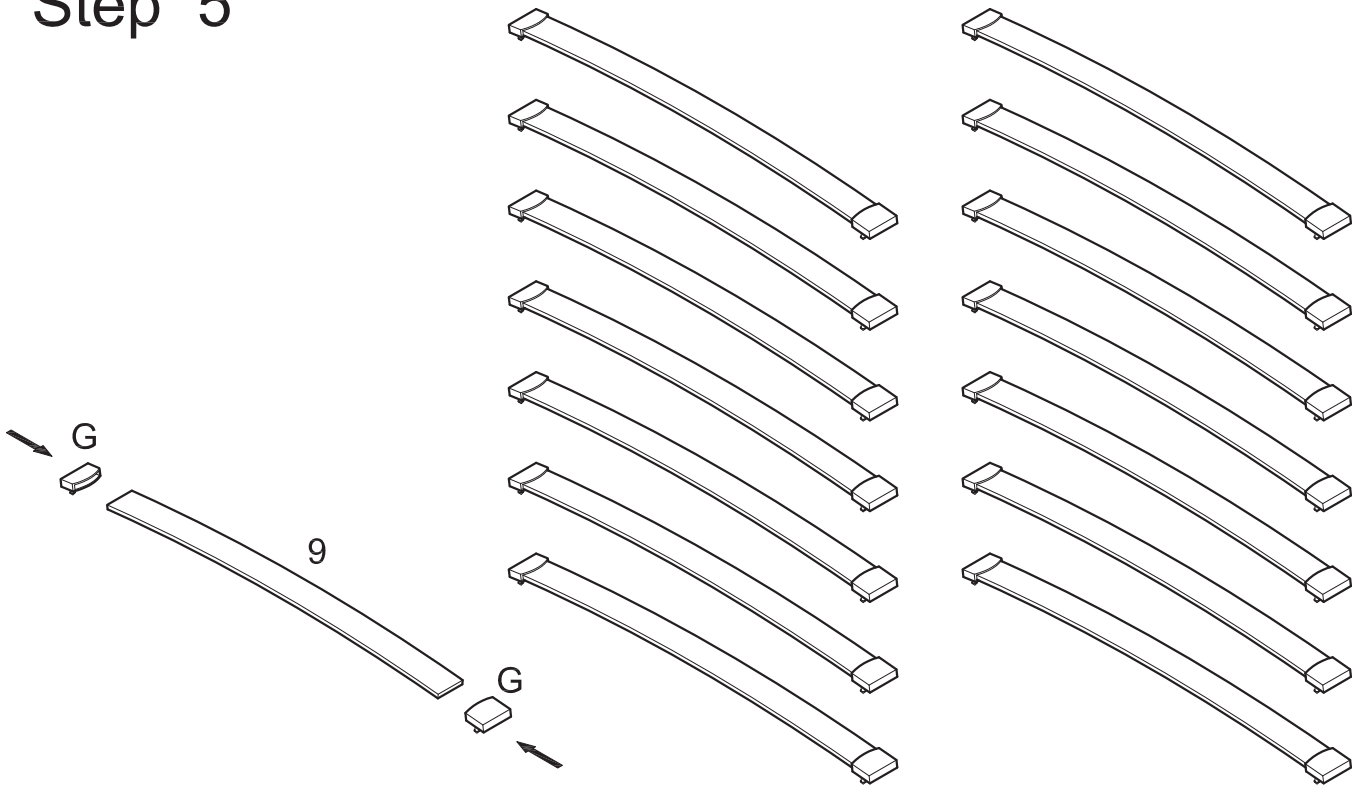

Fit end caps (G) onto slats (9).

## Step 6

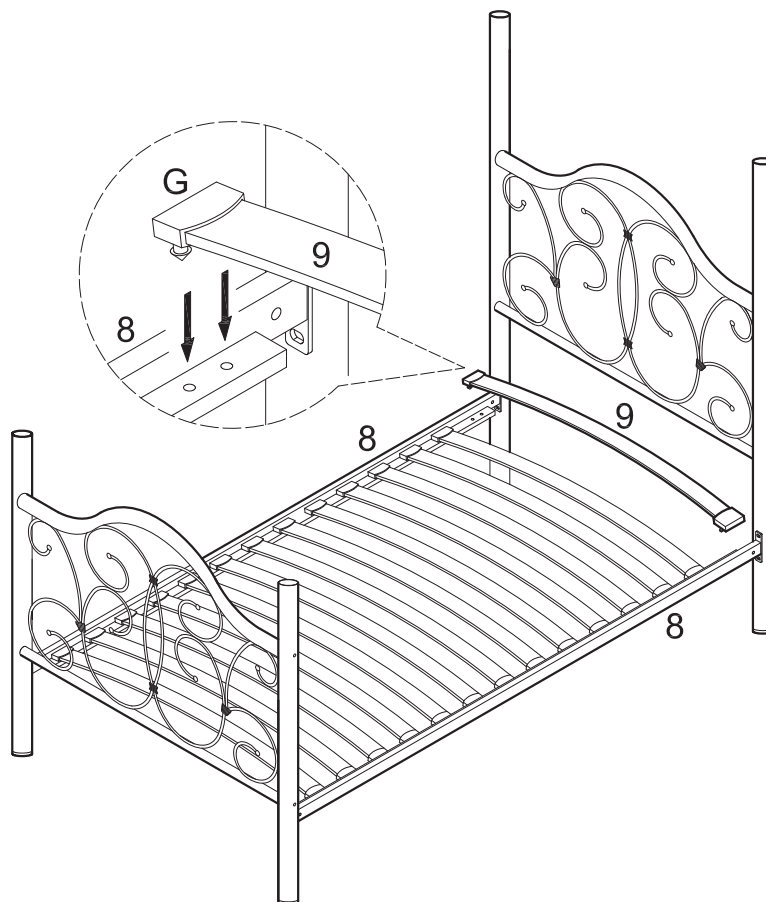

Attach slats (9) to crossbars (8) using end caps (G). *Slats (9) should curve slightly up.*

# Step 7A

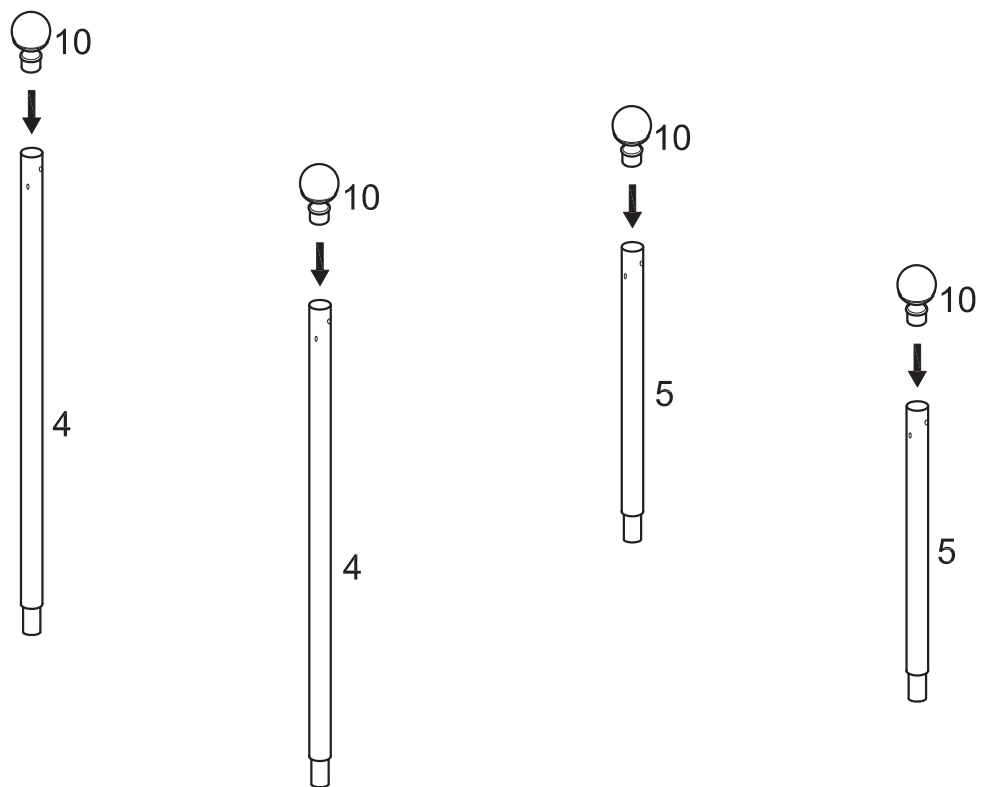

Insert decorative end caps (10) into poles (4,5).

# Step 8A

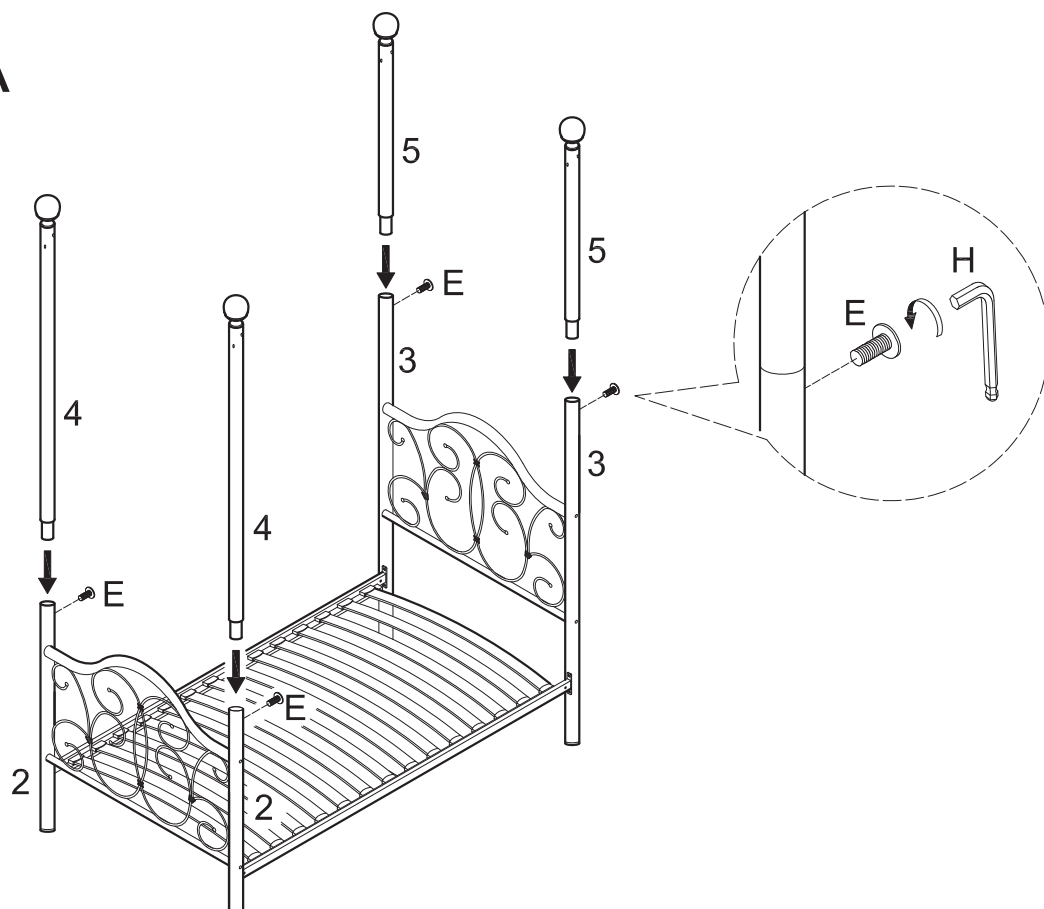

Insert poles (4) into legs (2) and poles (5) into legs (3). Secure poles (4,5) using bolts (E). Tighten bolts (E) with wrench (H).



## Step 9A

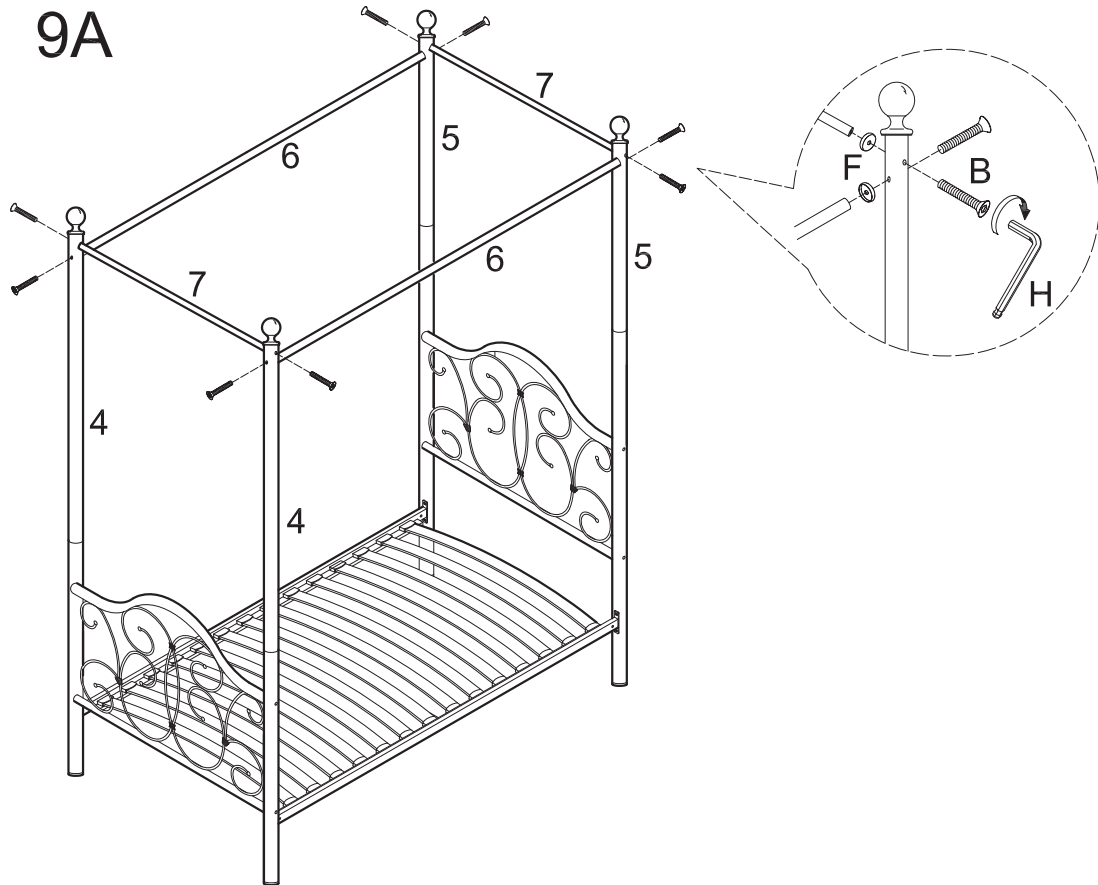

Attach poles (6,7) to poles (4,5) using bolts (B) and washers (F). Washers (F) will fit onto the ends of poles (6,7). Tighten bolts (B) with wrench (H).

## Step 10A

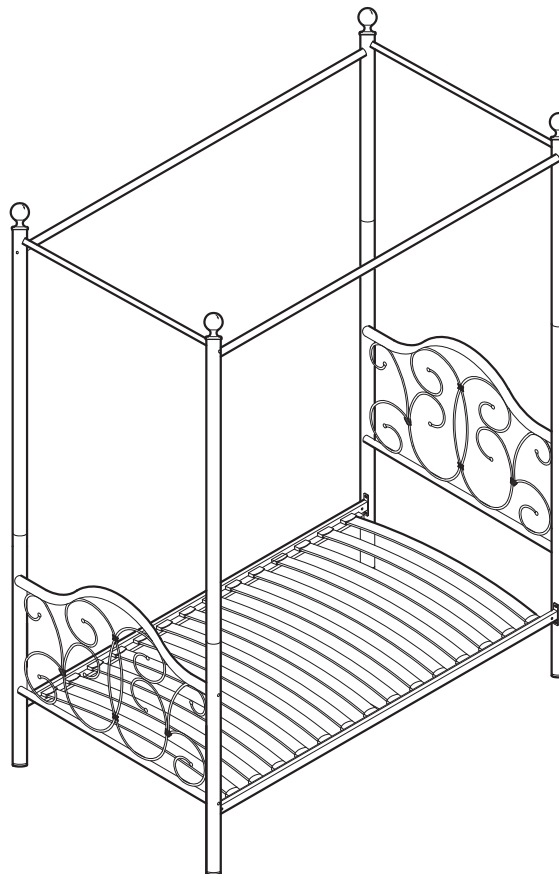

Option A  
Final Assembly

## Step 7B

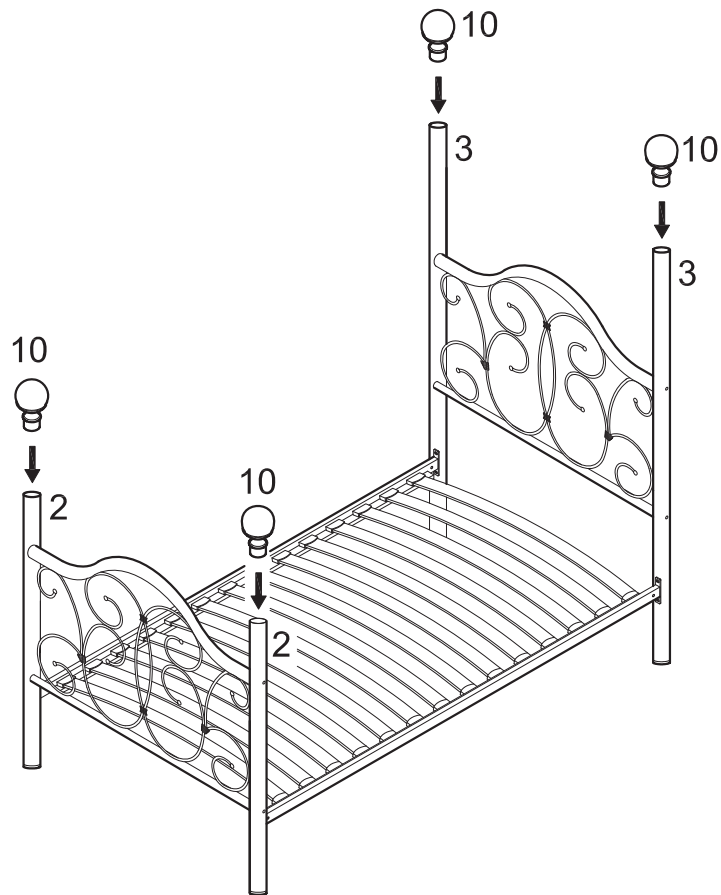

Insert decorative end caps (10) into poles (2,3).

## Step 8B

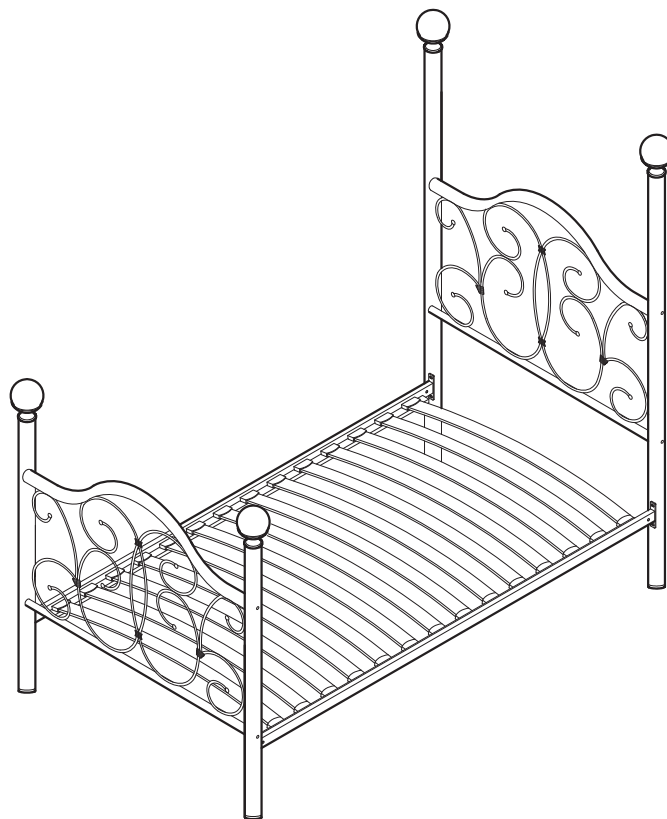

Option B  
Final Assembly