

W Walker
E Edison
furniture company

Item #: BT40
Assembly Instructions









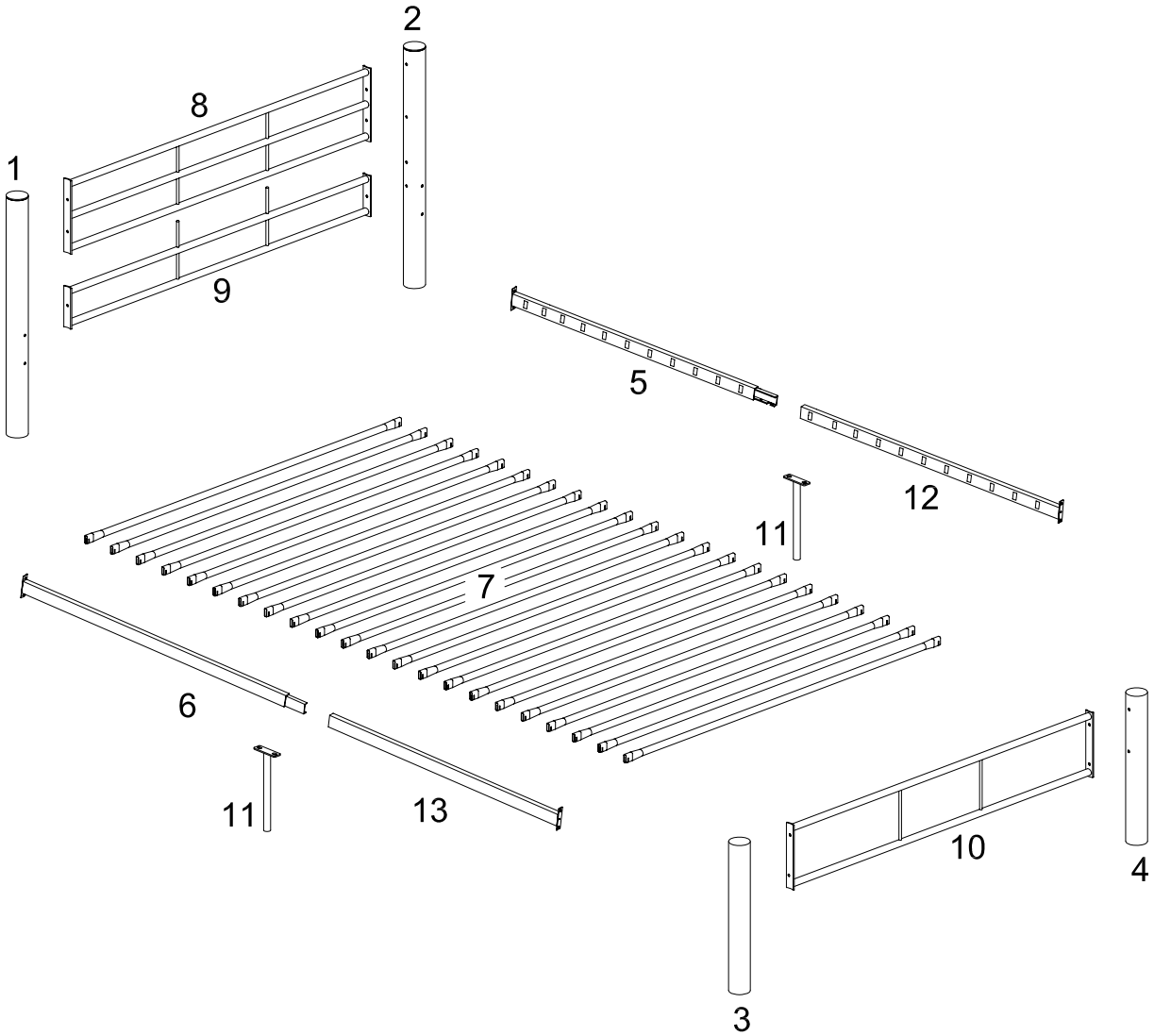

For our most current instructions, to request missing, lost or broken parts, or for any other Customer Service issues, please visit our website at www.walkeredison.com or call us at 877-207-5906.

Revised 01/2011

Parts List

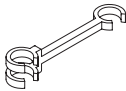

Hardware List

A		1/4"*1/2"	Small bolt	12 pcs
B		1/4"*1/2"	Small bolt	4 pcs
C		1/4"*1"	Large bolt	8 pcs
D		Ø16	Small washer	12 pcs
E		Ø24	Large washer	8 pcs
F		1/4"	Spring washer	8 pcs
G		M4	Wrench	1 pcs
H			Plastic link	21 pcs
I			Plastic tab lock	44 pcs

*The hardware quantities listed above are required for proper assembly.
Some extra hardware may also have been included.*

Step 1

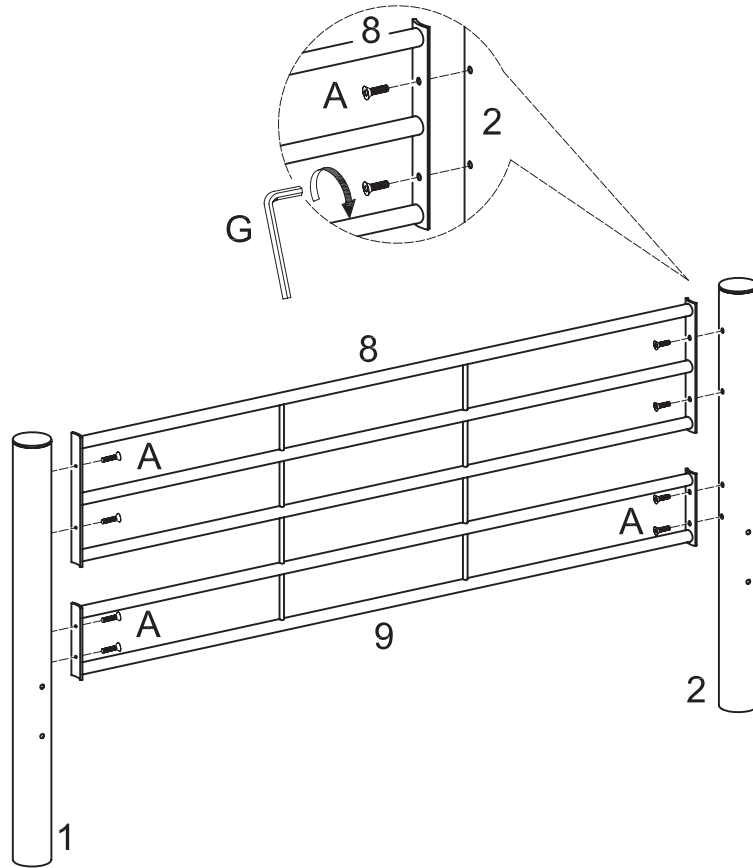

Attach headboard rails (8,9) to legs (1,2) using small bolts (A). Tighten small bolts (A) with wrench (G).

Step 2

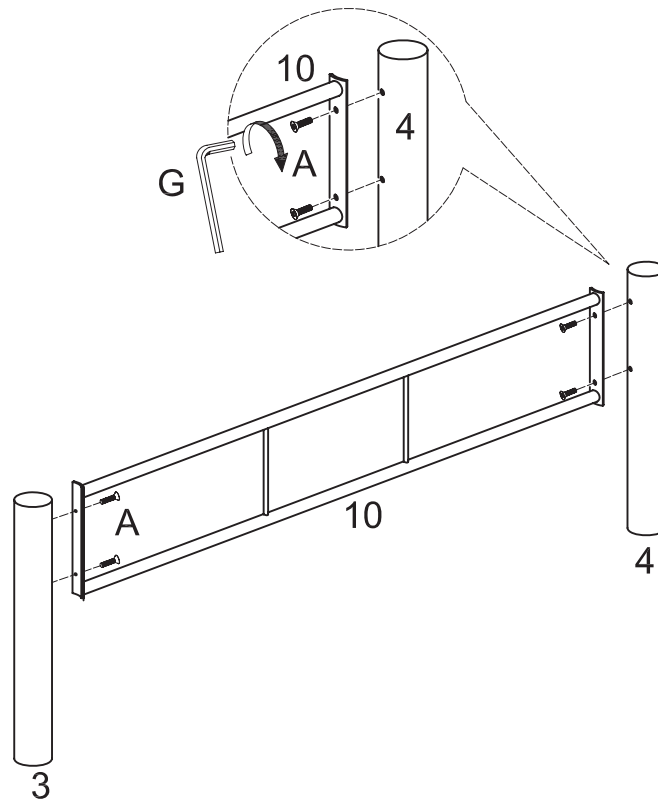

Attach baseboard rail (10) to legs (3,4) using small bolts (A). Tighten small bolts (A) with wrench (G).

Step 3

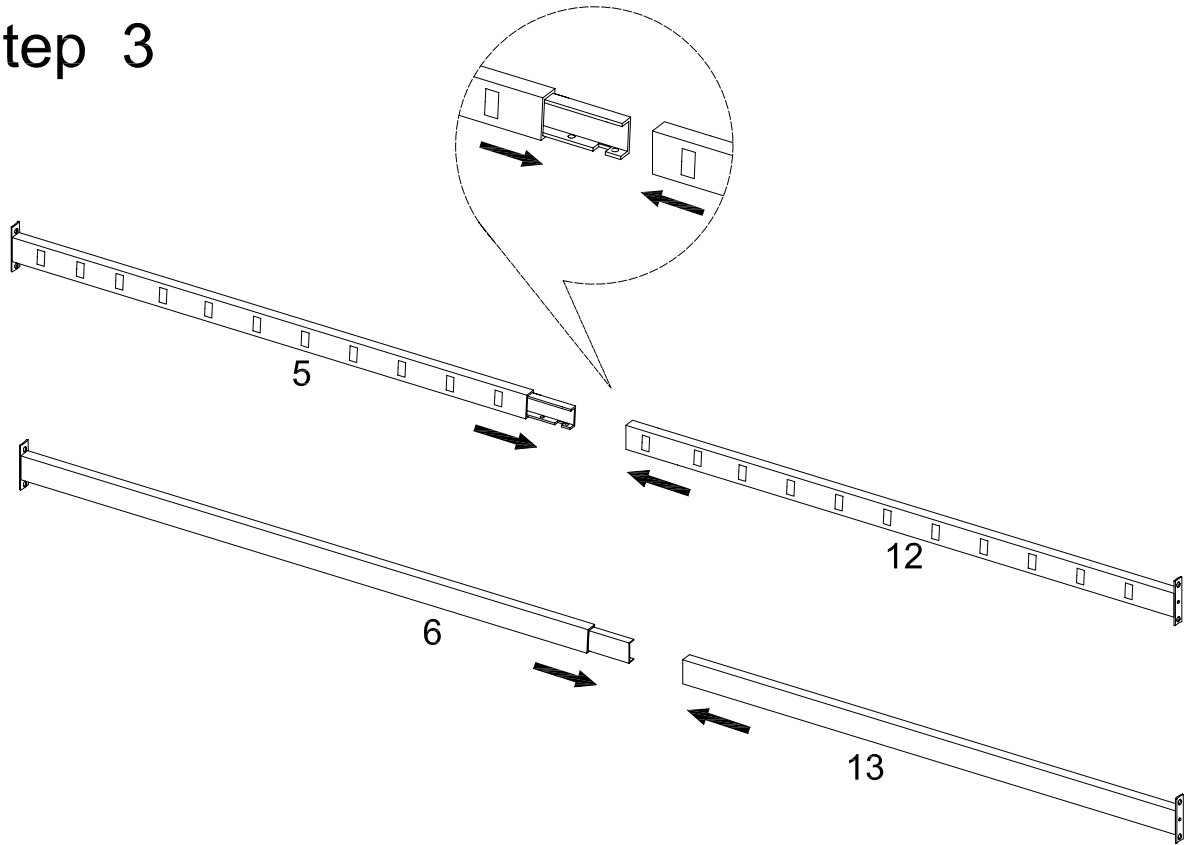

Slide crossbars (5/6) into crossbars (12/13)

Step 4

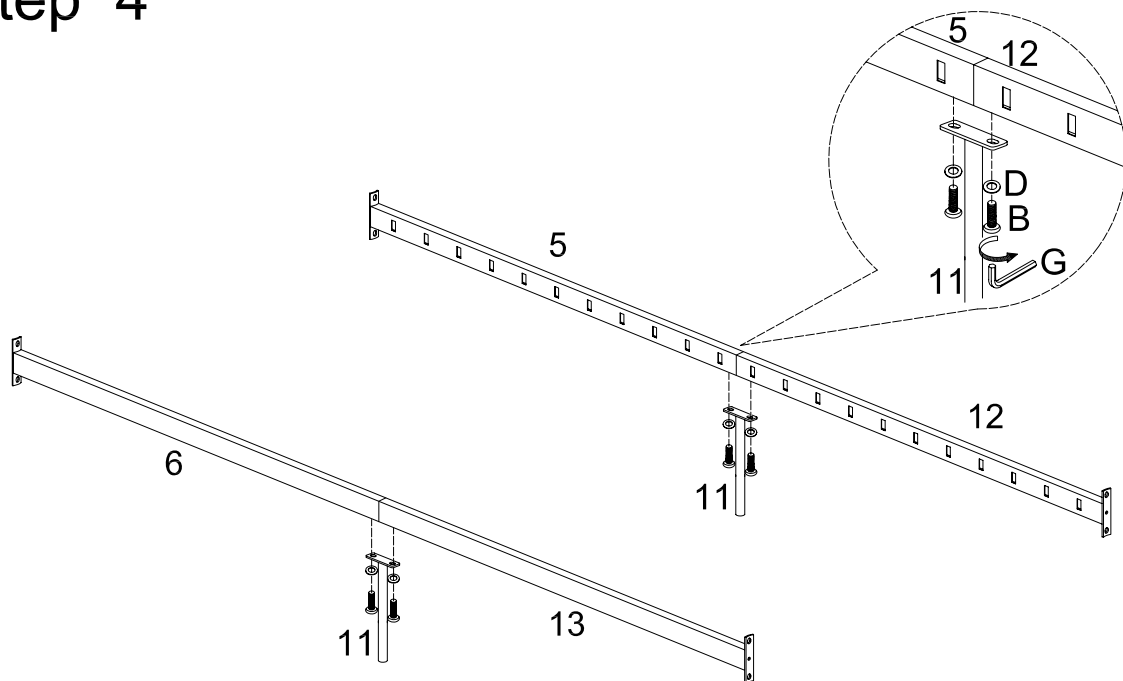

Attach support legs (11) to both sets of crossbars (5,12/6,13) using small bolts (B) and small washers (D). Tighten small bolts (B) with wrench (G).

Step 5

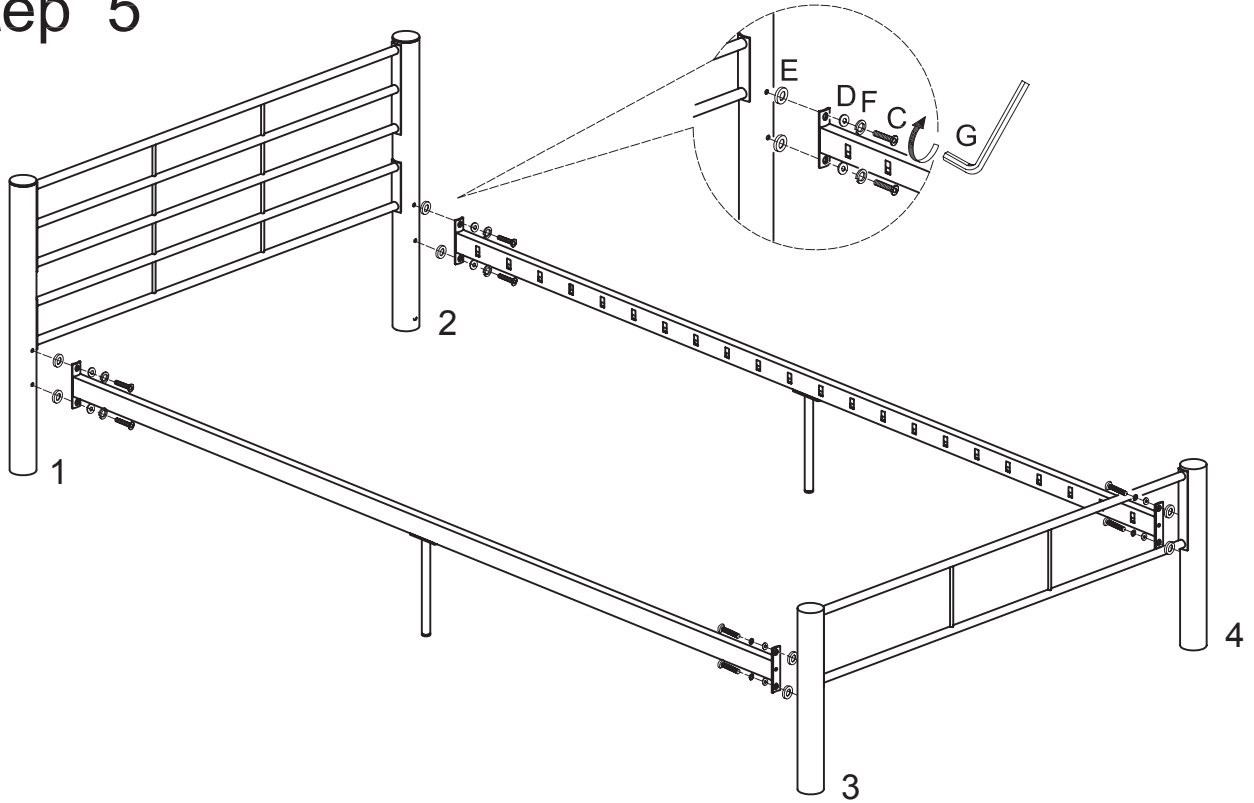

Attach the crossbar assemblies from the previous step to legs (1,2,3,4) using large bolts (C), spring washers (F), small washers (D) and large washers (E). *Ensure that the slots along each crossbar assembly face inwards when attached to legs (1,2,3,4). Also, note the diagram above for proper placement of hardware.* Tighten large bolts (C) with wrench (G).

Step 6

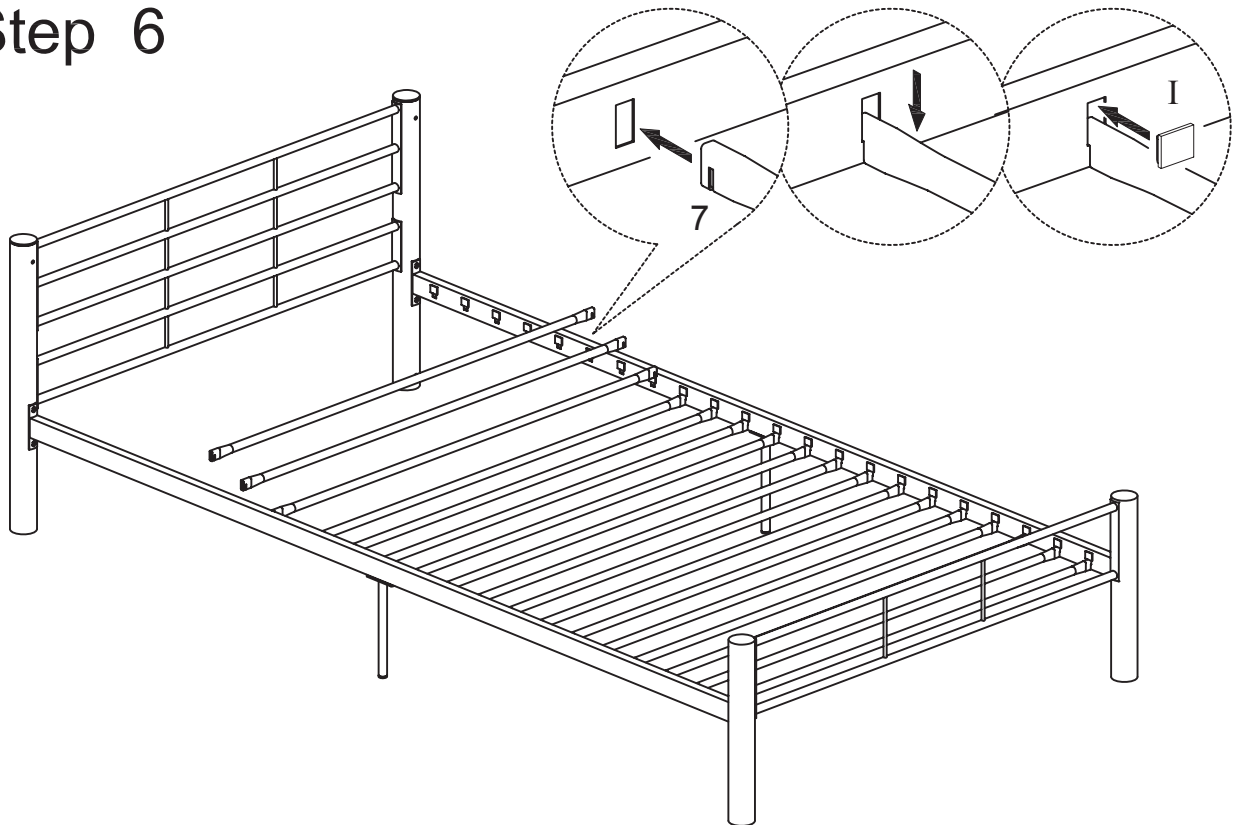

Insert mattress support bars (7) into the slots of the crossbar assemblies. Secure mattress support bars (7) by snapping plastic tab locks (I) into the slots of the crossbar assemblies. *It may be necessary to apply more pressure to some plastic tab locks than others.*

Step 7

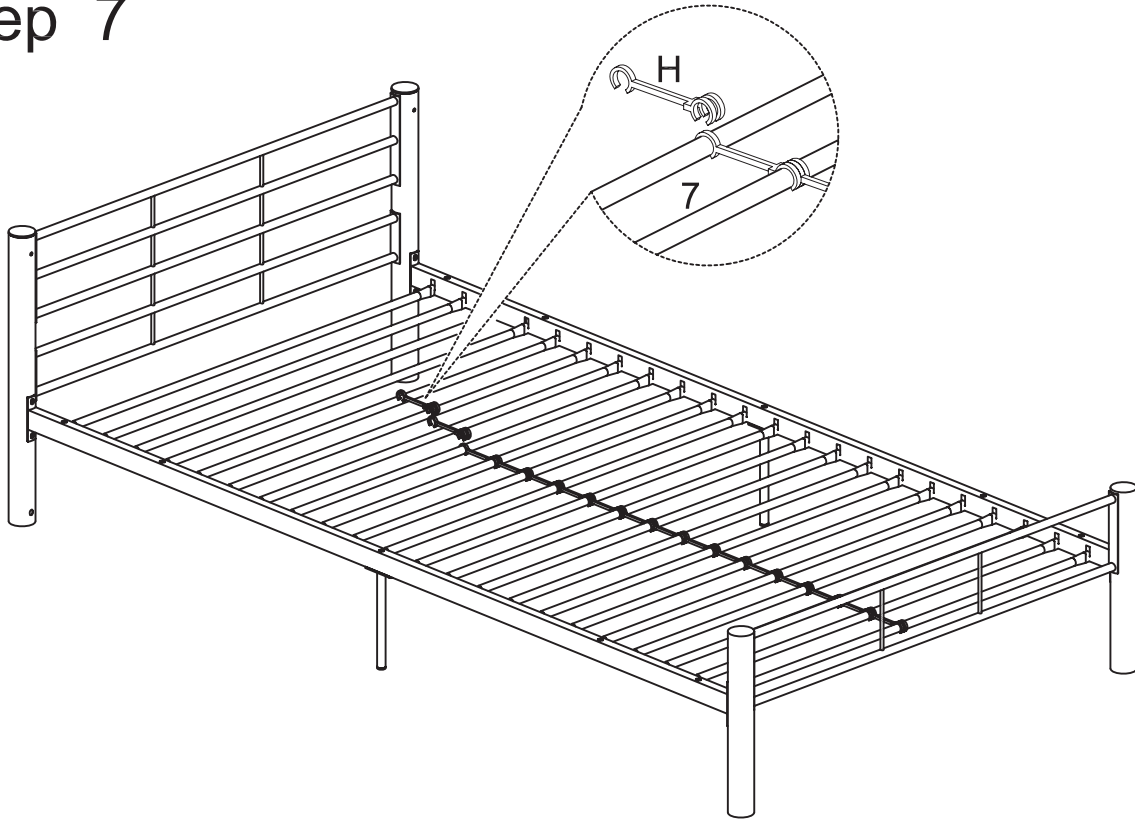

Snap plastic links (H) onto the middle of mattress support bars (7) along the length of the bed.

Step 8

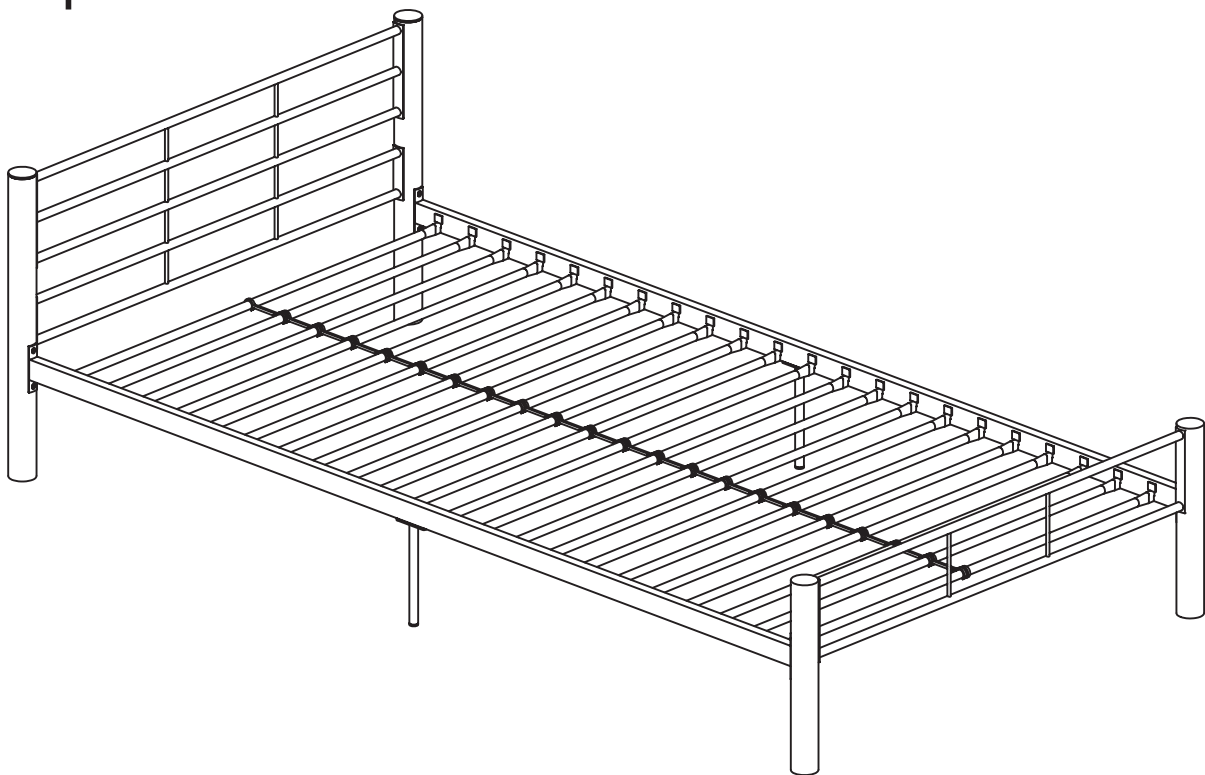

Final Assembly