



GRAPHICS MAY VARY

OPERATOR'S MANUAL



Copyright © Lincoln Global Inc.

• World's Leader in Welding and Cutting Products •

• Sales and Service through Subsidiaries and Distributors Worldwide •

TABLE OF CONTENTS	Page
SAFETY WARNINGS – READ BEFORE USING	1
HELMET INFORMATION	2
SPECIFICATIONS	3
OPERATING INSTRUCTIONS	4
CARTRIDGE OPERATIONS/FEATURES	5
SHADE GUIDE SETTINGS	6
CARTRIDGE AND LENS REPLACEMENT	7
TROUBLESHOOTING	8
WARRANTY INFORMATION	9
REPLACEMENT PARTS	9

SAFETY WARNINGS – READ BEFORE USING

WARNING

ARC Rays can injure eyes and burn skin



- Before welding, always inspect helmet and filter lens to be sure they are fitted properly, in good condition and not damaged.
- Check to see that the clear lens is clean and securely attached to the helmet.
- Always wear safety glasses or goggles under the welding helmet and protective clothing to protect your skin from radiation, burns and spatter.
- Ensure that optical radiation from other welder's arcs in the immediate area does not enter in from behind the helmet and auto-darkening filter.

Note: Auto-darkening filters in Lincoln helmets are designed to protect the user against harmful ultra-violet and infrared rays both in the dark and light states. No matter what shade the filter is set to, the UV/IR protection is always present.

FUMES AND GASES can be dangerous to your health.



- Keep your head out of fumes.
- Use enough ventilation or exhaust at the arc or both to keep fumes and gases from your breathing zone and general area.
- **When welding with electrodes which require special ventilation such as stainless or hard facing (see instructions on container or MSDS) or on lead or cadmium plated steel and other metals or coatings which produce highly toxic fumes, keep exposure as low as possible and within applicable OSHA PEL and ACGIH TLV limits using local exhaust or mechanical ventilation. In confined spaces or in some circumstances, outdoors, a respirator may be required. Additional precautions are also required when welding on galvanized steel.**

Refer to <http://www.lincolnelectric.com/safety>
for additional safety information.

HELMET INFORMATION

This Auto-Darkening Welding Helmet will automatically change from a light state (shade DIN4) to a dark state (shade DIN9-13) when arc welding starts.

The filter automatically returns to a light state when the arc stops.

Match your welding application to the shade indicated on the shade chart. (See Page 6)

- Operating temperature: 14°F ~ 131°F (-10°C ~ 55°C).
- Do not use or open the auto-darkening filter if damaged by shock, vibration or pressure.
- Keep the sensors and solar cell clean. Clean the filter cartridge using a soapy water solution and soft cloth which should be damp but not saturated.

This Auto-Darkening Welding Helmet is designed for use with GMAW, GTAW, MMAW welding, or Plasma Arc and air carbon arc cutting.

The cartridge provides protection from harmful UV and IR radiation, in both dark and light states.

The cartridge contains two sensors to detect the light from the welding arc, resulting in the lens darkening to a selected welding shade.

- Do not use solvents or abrasive cleaning detergent.
- If cover lens is spattered or covered with dirt, it should be replaced immediately.
- Use only replacement parts specified in this manual.
- Do not use the helmet without inside and outside cover lenses properly installed.

SPECIFICATIONS

Optical Class	1/1/1/1
LCD Viewing Area	96 x 47mm (3.78 x 1.85in.)
Cartridge size	110 x 90mm (4.33 x 3.54in.)
UV/IR Protection	Up to Shade DIN 16 at all times
Arc Sensors	2
Light State Shade	DIN 4
Variable Welding Shades	DIN 9 to 13 and Grind
Shade Control	External knob - full adjustment
Power Supply	Solar cell with battery assist
Battery	CR2450 Lithium battery
Power On/Off	Fully automatic
Light to Dark Switching Time	0.00004 sec. (1/25,000 sec.)
Sensitivity Control	Variable
Delay Control (Dark to Light)	0.1 sec. min. ~ 1.0 sec. max.
TIG Rating	DC ≥ 2 amps; AC ≥ 2 amps
Operating Temperature	14°F ~ 131°F (-10°C ~ 55°C)
Storage Temperature	-4° ~ 158°F (-20°C ~ 70°C)
Total Weight	Black 532.5g (18.8 Oz.) Graphic 552.0g (19.5 Oz.)
Compliance ⁽¹⁾	ANSI Z87.1-2010/CSA Z94.3/CE EN379

⁽¹⁾ Headgear compliance with ANSI Z87.1 is without sweatband installed.

OPERATING INSTRUCTIONS

Headgear Adjustment

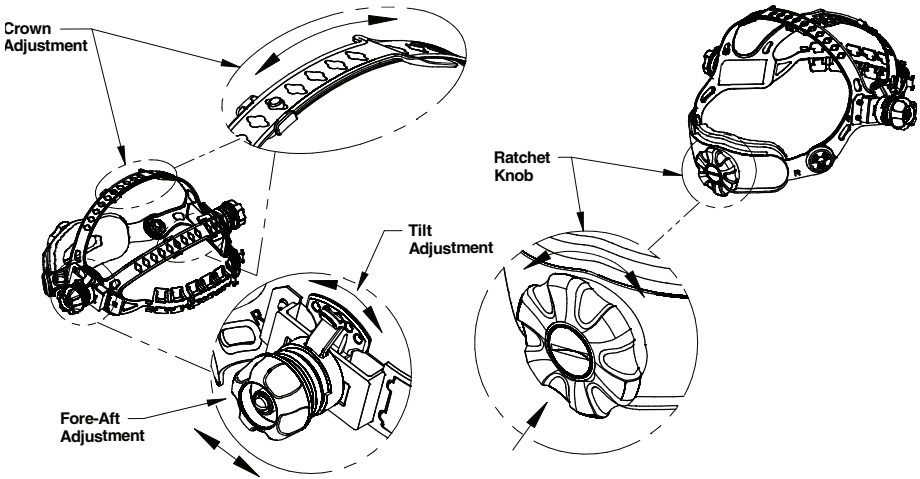

HEAD SIZE ADJUSTMENT: HEADGEAR TIGHTNESS is adjusted by pushing in the Ratchet Knob and turning to adjust for the desired head size. This knob is located at the back of the helmet. **HEADGEAR CROWN ADJUSTMENTS** are made by adjusting for comfort and snapping the pins into the holes to lock securely in place.

TILT: Tilt adjustment is located on the right side of the helmet. Loosen the right headgear tension knob and push the top end of the adjustment lever outward until the lever's Stop Tab clears the notches. Then rotate the lever up or down to the desired tilt position. The Stop will automatically engage again when released locking the helmet into position.

FORE / AFT ADJUSTMENT: Adjusts the distance between the user's face and lens. To adjust, loosen the outside tension knobs and slide forward or back to desired position and retighten. **NOTE:** Make sure both sides are equally positioned for proper operation.

CARTRIDGE OPERATION/FEATURES

Variable Shade Control

The shade can be adjusted from shade 9 to 13 based upon welding process or application (refer to Shade selection chart on page 6). The variable shade control knob is mounted on the exterior of the helmet shell. **Grind mode** can be selected by rotating the shade control knob counterclockwise till an audible click is heard. **Grind mode is intended for grinding only not for welding.**

Sensitivity Knob

You can adjust the light sensor by turning the **Sensitivity** knob to the left or right as shown in the figure below. Turning the knob to the right increases sensitivity which makes the ADF cartridge more sensitive to light. When the helmet is used in the presence of excess ambient light or with another welding machine close by, improved helmet performance can be obtained with a **lower** setting turning the knob to the left to reduce the sensitivity.

Delay Time Knob

This control is designed to protect the welder's eyes from the strong residual rays after welding. Changing the **Delay Time** knob will vary dark to light time between 0.1 second (minimum) to 1.0 second (maximum). Turning the **Delay Time** knob to the right is maximum (1.0 second). This setting is recommended for high amperage applications where the weld puddle is still very bright after the welding arc has ceased and for situations where the filter may be temporarily blocked from seeing the welding arc.

Power

This ADF cartridge is powered by a replaceable battery and solar power. The battery is located at the top of the ADF cartridge. Replace battery when **LOW BATTERY** light is lit. See the specification chart on page 3 for type of battery required.

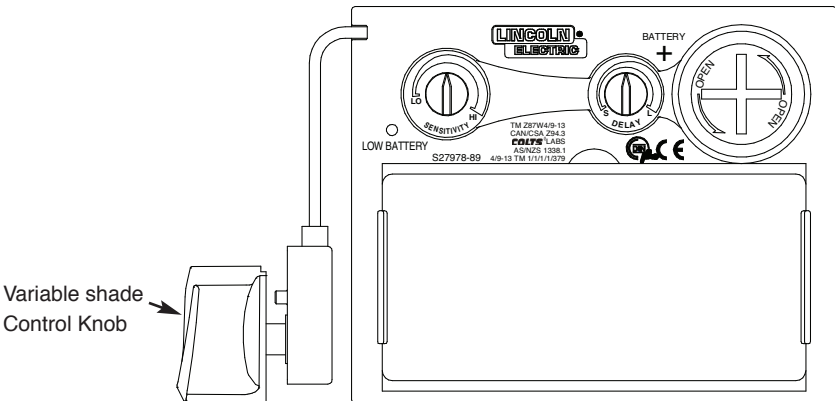

HELMET CARE AND MAINTENANCE

Cleaning: Clean helmet by wiping with a soft cloth. Clean cartridge surfaces regularly. Do not use strong cleaning solutions. Clean sensors and solar cells with soapy water solution and a clean cloth and wipe dry with a lint-free cloth. Do **NOT** submerge shade cartridge in water or other solution.

Storage: Store in a clean, dry location.

SHADE GUIDE SETTINGS

GUIDE FOR SHADE NUMBERS				
OPERATION	ELECTRODE SIZE 1/32 in. (mm)	ARC CURRENT (A)	MINIMUM PROTECTIVE SHADE	SUGGESTED(1) SHADE NO. (COMFORT)
Shielded metal arc welding	Less than 3 (2.5)	Less than 60	7	–
	3-5 (2.5-4)	60-160	8	10
	5-8 (4-6.4)	160-250	10	12
	More than 8 (6.4)	250-550	11	14
Gas metal arc welding and flux cored arc welding		Less than 60	7	–
		60-160	10	11
		160-250	10	12
		250-500	10	14
Gas tungsten arc welding		Less than 50	8	10
		50-150	8	12
		150-500	10	14
Air carbon Arc cutting	(Light)	Less than 500	10	12
	(Heavy)	500-1000	11	14
Plasma arc welding		Less than 20	6	6 to 8
		20-100	8	10
		100-400	10	12
		400-800	11	14
Plasma arc cutting	(Light) ⁽²⁾	Less than 300	8	9
	(Medium) ⁽²⁾	300-400	9	12
	(Heavy) ⁽²⁾	400-800	10	14
Torch brazing		–	–	3 or 4
Torch soldering		–	–	2
Carbon arc welding		–	–	14
PLATE THICKNESS				
	in.	mm		
Gas welding Light Medium Heavy	Under 1/8	Under 3.2		4 or 5
	1/8 to 1/2	3.2 to 12.7		5 or 6
	Over 1/2	Over 12.7		6 or 8
Oxygen cutting Light Medium Heavy	Under 1	Under 25		3 or 4
	1 to 6	25 to 150		4 or 5
	Over 6	Over 150		5 or 6

(1) As a rule of thumb, start with a shade that is too dark, then go to a lighter shade which gives sufficient view of the weld zone without going below the minimum. In oxyfuel gas welding or cutting where the torch produces a high yellow light, it is desirable to use a filter lens that absorbs the yellow or sodium line the visible light of the (spectrum) operation.

(2) These values apply where the actual arc is clearly seen. Experience has shown that lighter filters may be used when the arc is hidden by the workpiece.

Data from ANSI Z49.1-2005

If your helmet does not include any one of the shades referenced above, it is recommended you use the next darker shade.

CARTRIDGE AND LENS REPLACEMENT

Replacing Front Clear Cover Lens: Replace the front cover lens if it is damaged. Remove ADF holder assembly per Figure 1. Remove front cover lens from helmet assembly. Carefully remove gasket from cover lens. Install new cover lens into gasket and assemble to helmet shell. Make sure to assemble cover lens and gasket into helmet shell the same way as it was removed.

Replacing Inside Clear Lens: Replace the inside clear lens if it is damaged. Remove ADF holder assembly per Figure 1. Remove shade cartridge from ADF holder. Place your fingernail in recess above cartridge view window and flex lens upwards until it releases from edges of cartridge view window.

Change the Shade Cartridge: Remove ADF holder assembly from helmet shell. See figure 1 for removal. Flex top end of the ADF holder to allow for ADF cartridge to be removed from frame. Install new ADF cartridge into frame per figure 2 below. Make sure that the ADF cartridge is inserted in ADF holder correctly as shown. Install ADF holder assembly into helmet shell.

Position the shade potentiometer inside of the helmet with the shaft protruding through the hole. From outside of the helmet, position dial panel onto the potentiometer shaft and secure potentiometer to shell, rotate shaft counter-clockwise until an audible click is heard and install shade control knob with pointer positioned at **Grind** location on dial panel.

INSTALLING AN AFTERMARKET MAGNIFYING LENS:

Simply slide the magnifying lens into the short rail located on the sides of ADF holder per Figure 3. Shade cartridge must be removed from ADF holder to install magnifying lens.

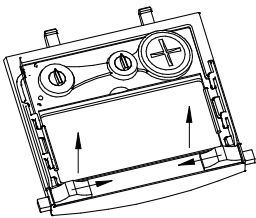

Figure 1

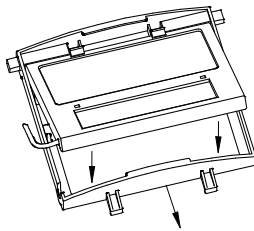

Figure 2

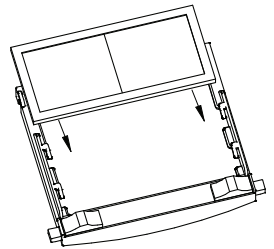

Figure 3

TROUBLESHOOTING GUIDE

Test your shade cartridge prior to welding by directing the front of the cartridge toward a bright source of light. Then, using your fingers, rapidly cover and uncover the sensors. The cartridge should darken momentarily as the sensor is exposed. A torch striker can also be used.

PROBLEM	POSSIBLE CAUSE	SOLUTION
Difficult to see through filter.	Front cover lens dirty.	Clean or replace front cover lens.
	Cartridge dirty.	Clean the Auto-Darkening cartridge with soapy water solution and soft cloth.
Filter does not darken when arc is struck.	Sensitivity is set too low.	Adjust sensitivity to required level.
	Front cover lens dirty.	Clean or replace front cover lens.
	Front cover lens is damaged.	Check for cracked or pitted front cover lens and replace as required.
	Sensors are blocked or Solar panel is blocked.	Make sure you are not blocking the sensors or solar panels with your arm or other obstacle while welding. Adjust your position so that the sensors can see the weld arc.
	Grind Mode Selected	Make sure proper shade is selected.
Filter darkening without arc being struck.	Sensitivity set too high.	Adjust sensitivity to required level.
Filter remains dark after completing a weld.	Delay time set too high.	Adjust delay time to required level.



WARNING

	ADF is cracked.	Cease (STOP) using this product if this problem exists. UV/IR protection may be compromised resulting in burns to the eyes and skin.	
	Weld spatter is damaging the filter.	Missing, damaged, broken, cracked or distorted front cover lens.	Replace front cover lens as needed.

WARRANTY INFORMATION

WARRANTY INFORMATION: Reference IMWS1 included in Literature.

SPATTER DAMAGE IS NOT COVERED BY WARRANTY:

Do not use this product without the correct protective clear lenses installed properly on both sides of the Auto-Darkening Filter cartridge (ADF). The clear lenses supplied with this helmet are properly sized to work with this product and substitutions from other suppliers should be avoided.

REPLACEMENT PARTS

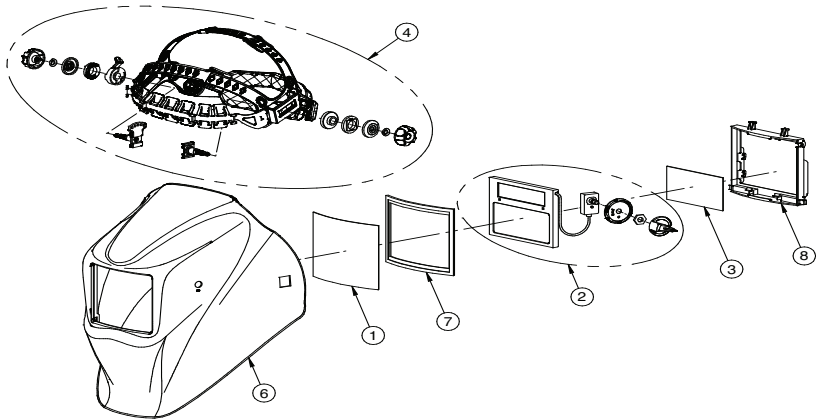

ITEM	PART NO.	DESCRIPTION	QTY
1	KP3043-1	OUTSIDE CLEAR LENS (PKG. QTY: 5)	1
2	KP2853-2	ADF CARTRIDGE	1
3	KP2897-1	INSIDE CLEAR LENS (PKG. QTY: 5)	1
4	KP3908-1	HEADGEAR ASSEMBLY (INCLUDING SWEATBAND)	1
5*	KP2930-1	SWEATBAND (PKG. QTY: 2)	1
6	S27978-54	REPLACEMENT SHELL	1
7	S27978-58	OUTSIDE CLEAR LENS SEAL	1
8	S27978-55	ADF HOLDER	1

OPTIONAL ACCESSORIES		
PART NO.	DESCRIPTION	QTY
KP3046-100	CHEATER LENS 1.00 MAGNIFICATION	1
KP3046-125	CHEATER LENS 1.25 MAGNIFICATION	1
KP3046-150	CHEATER LENS 1.50 MAGNIFICATION	1
KP3046-175	CHEATER LENS 1.75 MAGNIFICATION	1
KP3046-200	CHEATER LENS 2.00 MAGNIFICATION	1
KP3046-225	CHEATER LENS 2.25 MAGNIFICATION	1
KP3046-250	CHEATER LENS 2.50 MAGNIFICATION	1
KP3047-1	HARD HAT ADAPTER	1

*Not illustrated



• World's Leader in Welding and Cutting Products •

• Sales and Service through Subsidiaries and Distributors Worldwide •

Cleveland, Ohio 44117-1199 U.S.A. TEL: 216.481.8100 FAX: 216.486.1751 WEB SITE: www.lincolnelectric.com