



SAS Radison Royal. Copenhagen, Denmark. Photo: Kaslov Studio

Weblink
141

Design
Poul Henningsen

Concept
PH 4½-3½ Glass Table (1927) provides soft illumination. The PH 4½ family is based on the principle of a reflecting multi-shade system, producing a harmonious and glare free illumination. The shades are drawn over a logarithmic spiral, with the center of the light source placed in the spiral's focal point.

Finish
White opal glass. High lustre chrome plated.

Material
Base: High lustre chrome plated, spun brass. Shades: Handblown white opal glass. Anti-glare ring: Purple, spun aluminum. Top plate: High lustre chrome plated, spun brass. Stem: High lustre chrome plated, steel.

Mounting
Cord type: Black. Cord length: 9'. Switch: On/off switch located in the base.

Weight
Max. 22 lbs.

Label
cUL, Dry location. IBEW.

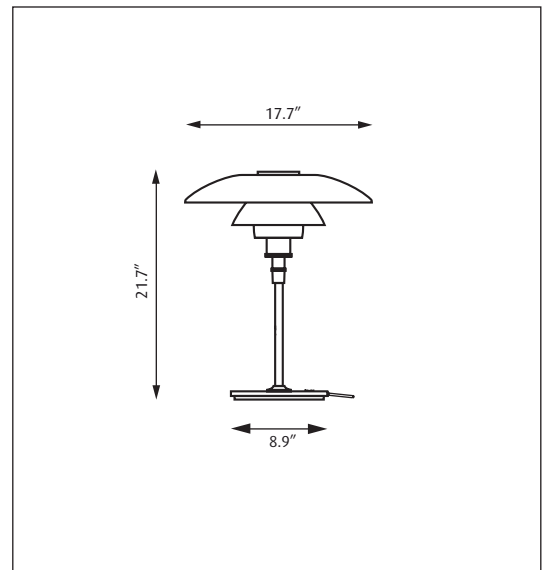

Product code	Light source	Voltage	Finish
PH4½-3½-T	1/100W/A-19/IF medium	120V	GLASS

Info notes:
I. All handblown opal glass shades are sandblasted on the undersides for uniform light distribution.
II. The comparable EU version has the following classification: Ingress Protection Code: IP20.



122



93