

Weblink
211

Design
Louise Campbell

Concept
Collage Pendant creates direct and diffuse illumination. The pendant consists of three staggered shades. All three have carefully been staggered in order to avoid any direct glare from the light source. The light and shadows from the fixture are ever changing when viewing the fixture from different angles.

Finish
Snow white (white), heavenly blue (blue), spring green (green), hotlips (pink) or smoke screen (smoke-tinted).

Material
Suspension: Naturally anodized aluminum. Shades: Laser cut acrylic.

Mounting
Suspension type: 3x stainless steel aircraft cables. Suspension length: 12'. Canopy: White. Cord type: 3-conductor, 18 AWG white PVC power cord. Cord length: 12'.

Weight
Max. 10 lbs.

Label
cUL, Dry location. IBEW.

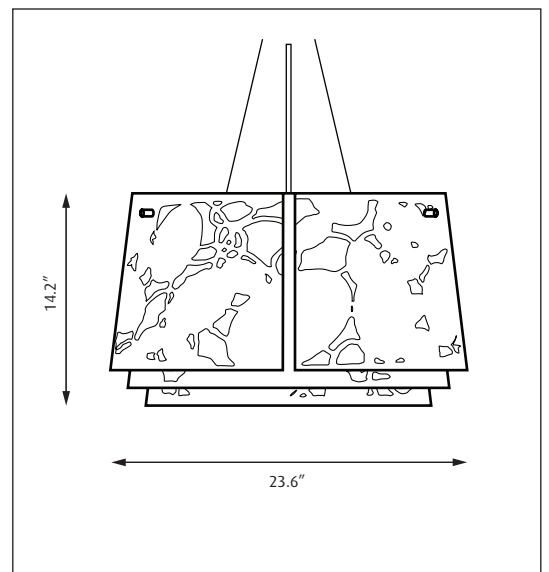

Product code	Light source	Voltage	Finish
COLLP	1/100W/A-19/IF medium	120V	HEAVENLY BLUE HOTLIPS SMOKE SCREEN SNOW WHITE SPRING GREEN

Info notes:
I. The colors (except for snow white) are mixed by hand.
II. The fixture comes with a unique identification number.
III. The comparable EU version has the following classification: Ingress Protection Code: IP20.



Snow white

Smoke
ScreenSpring
Green

Hotlips

Heavenly
Blue



Bar Bella Center
Copenhagen Furniture Fair
Copenhagen, Denmark
Photo
Anders Sune Berg