



**assembly instructions**  
**consignes d'assemblage**  
**instrucciones de ensamblaje**

### English

Nexera makes every effort to ensure the highest level of quality control at every step of production. Rarely a negligible defect may occur or a part may be missing from the package. If a defect does appear after complete assembly or a part is missing, please call our toll free Customer Service Line. You can also visit our web site or send an email. Please do not return the unit to the store.

### Français

En vue de vous assurer des pièces de première qualité, Nexera garantie un contrôle rigoureux de la qualité à chaque étape de production. Si toute fois une défectuosité a échappé à notre attention et que cette imperfection est apparente après l'assemblage ou qu'une pièce se trouve manquante, téléphonez-nous au numéro sans frais. Vous pouvez également visiter notre site internet ou nous faire parvenir un courriel. Vous n'avez pas à retourner le meuble au magasin.

### Español

Teniendo por objetivo asegurarle al cliente un producto de primera calidad, Nexera lleva acabo un riguroso control de calidad en cada etapa de la producción. Sin embargo, si algún defecto hubiese escapado de nuestra atención y afecta la apariencia de su mueble, o si le faltase alguna pieza, sirvase comunicarse con nosotros sin gasto alguno o en nuestro sitio web. Estimado cliente, ud no necesita devolver este producto al comerciante.

## Nexera Distribution



CANADA / USA  
Fax

**1-877-629-9022**  
1-450-629-4366



monday to friday  
7H AM - 3H PM

lundi au vendredi  
7h à 15h



E-Mail / Courriel  
[service@nexeradistribution.com](mailto:service@nexeradistribution.com)



Webpage / Page web  
[www.nexeradistribution.com](http://www.nexeradistribution.com)

produit no. product no. producto no.

# 220333

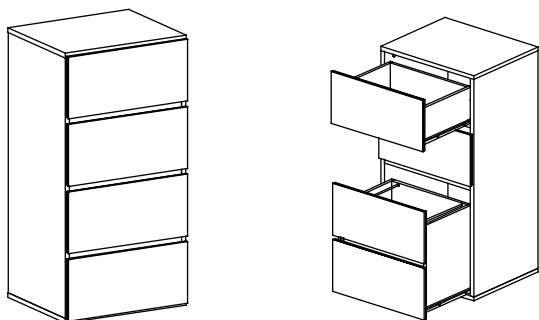

Lower drawer includes  
metal rods to accomodate  
letter size Pendaflex® system

**Le tiroir du bas inclus des tiges  
de métal conçues pour recevoir  
le système Pendaflex® format lettre**

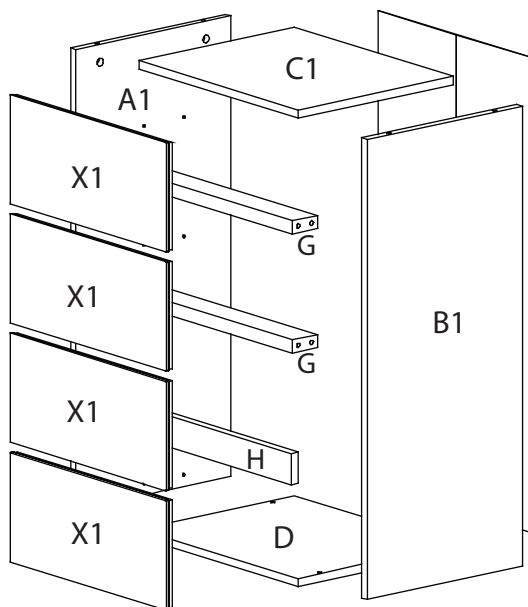

12x 

20-0111

1x 

20-2300

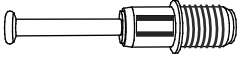
16x 

20-2200

22x 

20-0202

8x 

20-0203

4x 

20-2150

8x 

20-0204

4x 

20-1111

18x 

20-0207

4x 

20-1125

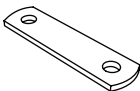
2x 

20-0603

22x 

20-0105

4x 

20-0120

18x 

20-0110

2x 

20-2157

1x **KIT** 

20-HH510

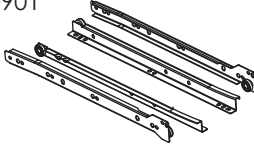
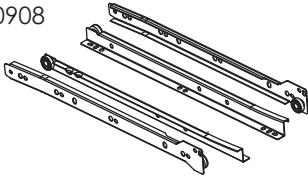
<p>2x</p> <p>20-0901</p> 	<p>1x</p> <p>20-0908</p> 
--	---

Tools required  
Outils requis



**HOW TO CLEAN:**  
Dampen a soft cloth with a mild solution of dishwashing detergent, squeeze excess water. Clean unit and wipe it dry.

**ENTRETIEN:**  
Trempez un chiffon doux dans une faible solution de détergent pour vaisselle et d'eau. Bien essorer. Nettoyez le meuble et essuyez le surplus d'eau.

**PARALIMPIAR:**  
Empape un paño suave con una solución de detergente suave y agua. Limpie la unidad y deje que se airee hasta que esté seca.



# 01

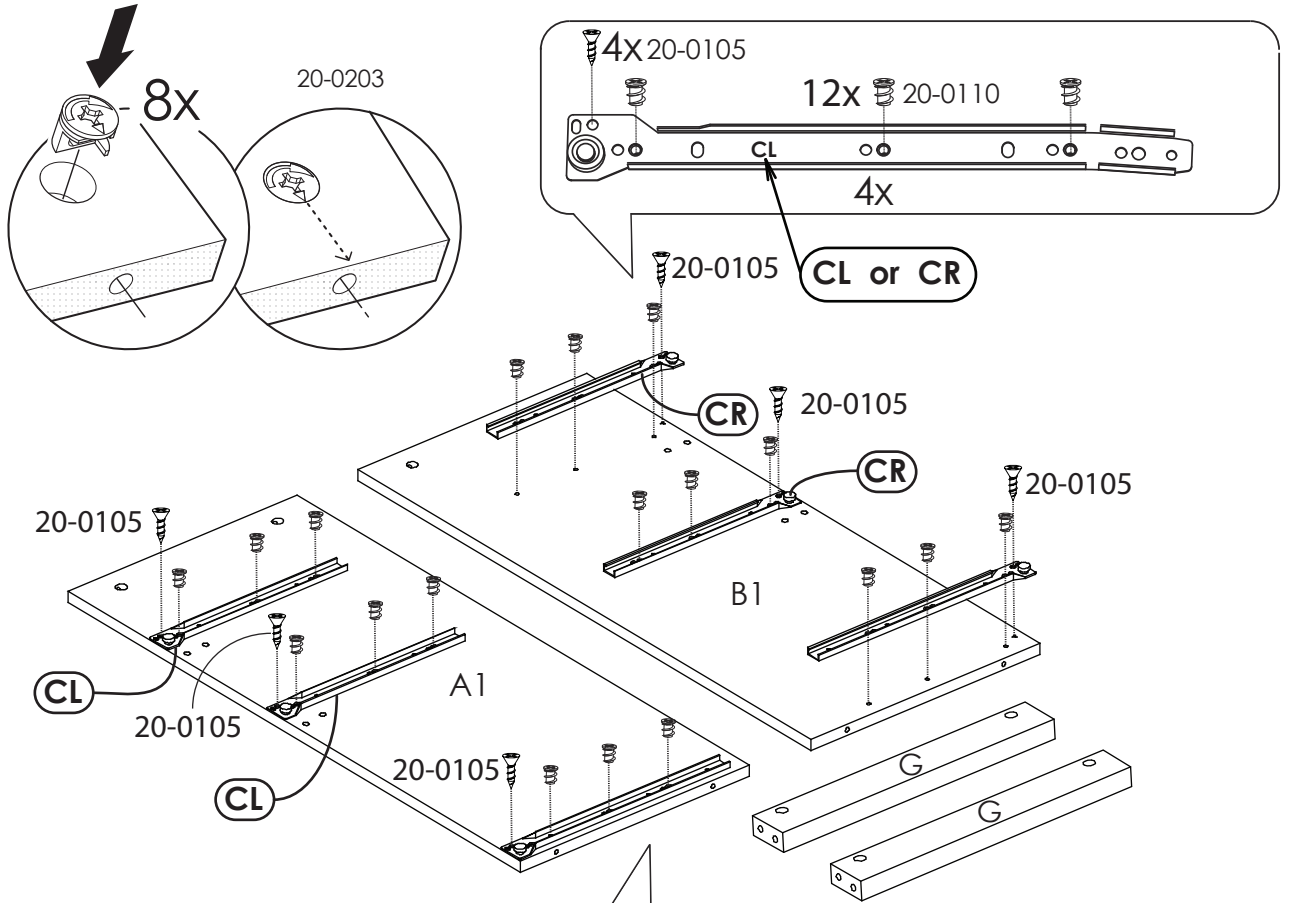

# 02

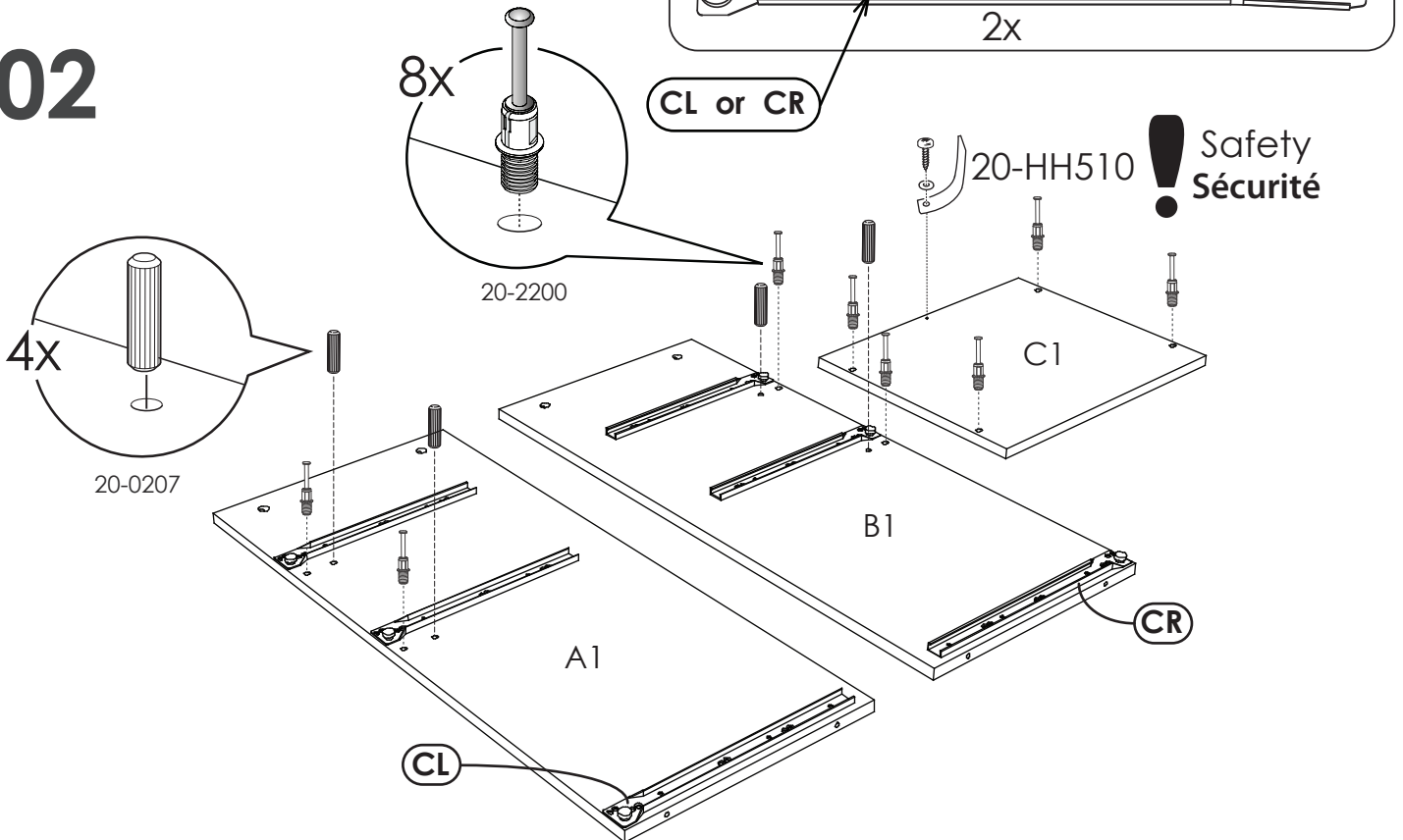

# 03

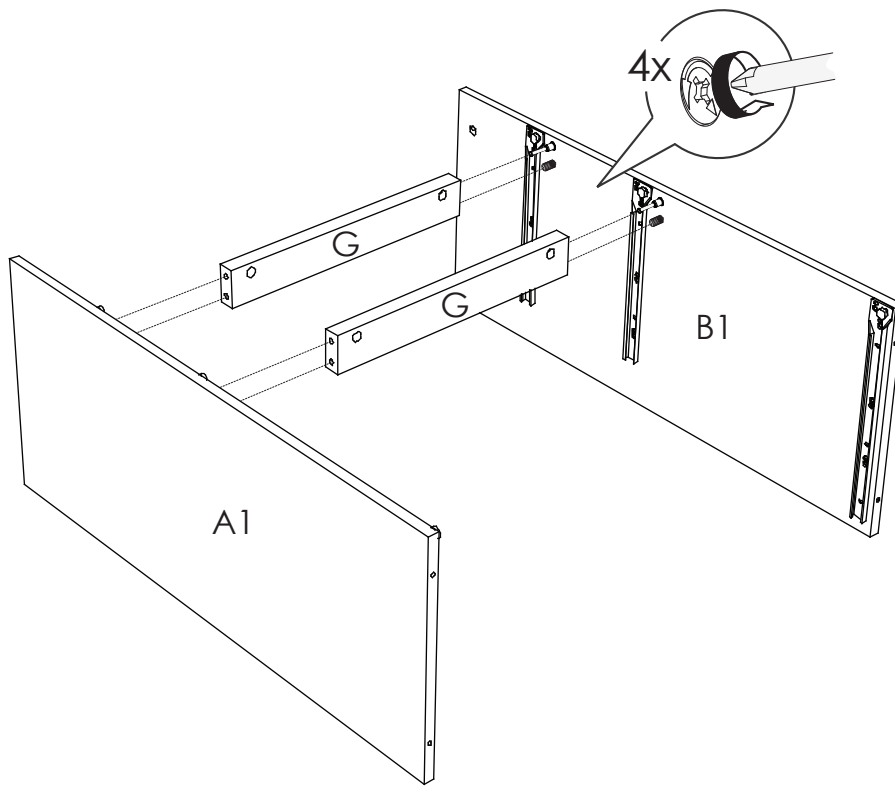

# 04

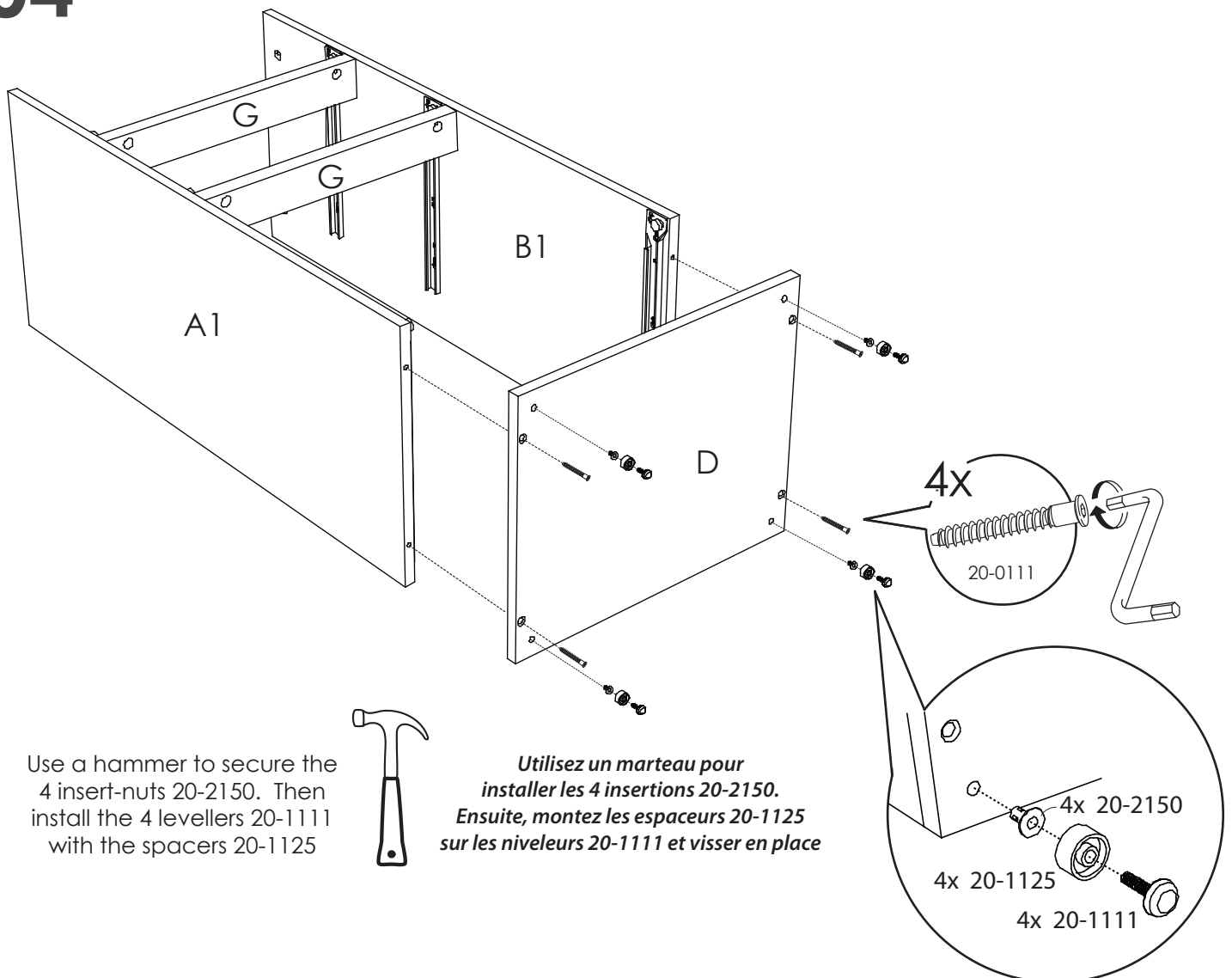

# 05

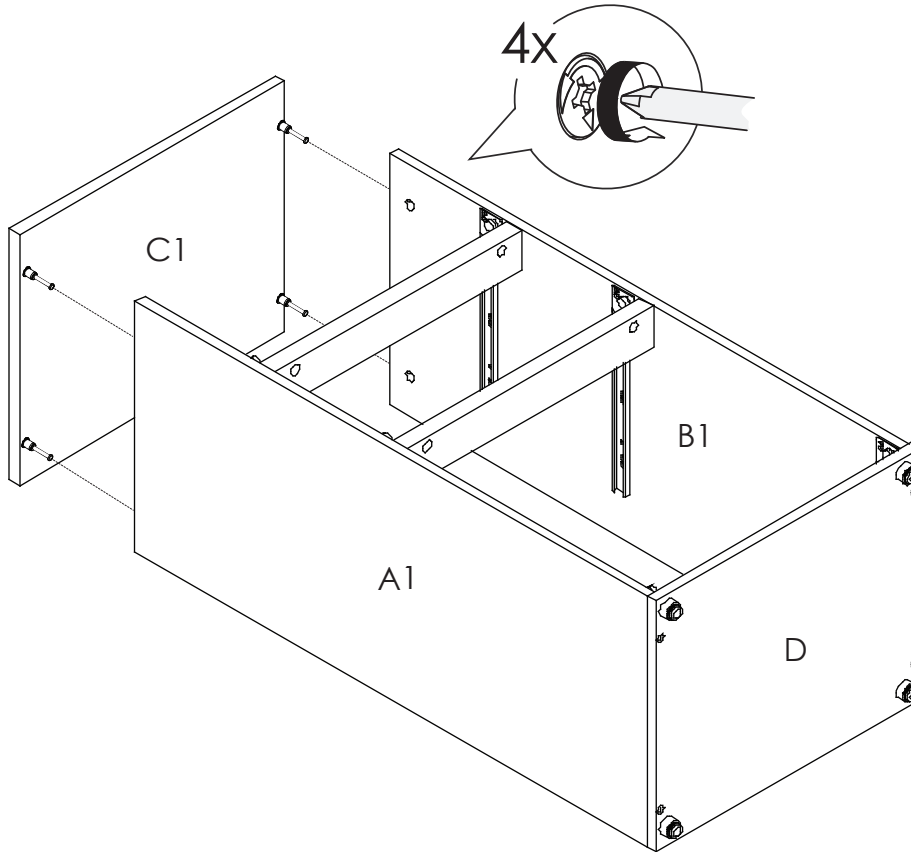

# 06

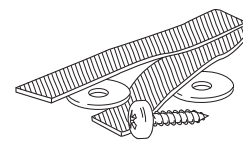
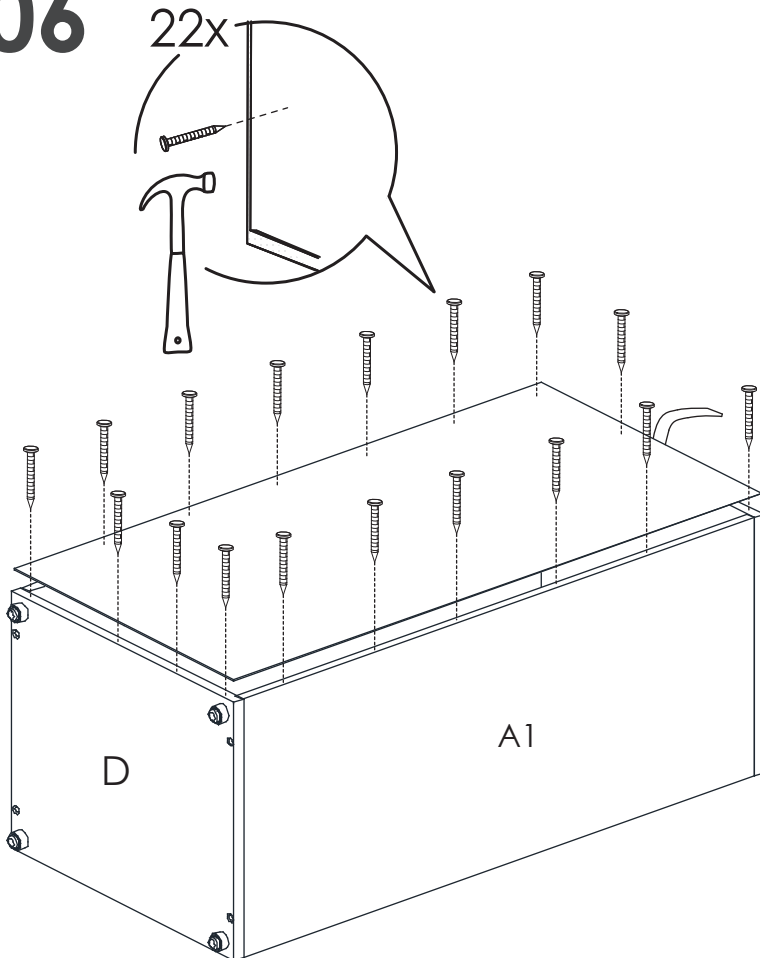

20-HH510

Safety  
Sécurité



Dear customer, **for your own safety** please use this hold-on device to secure the equilibrium of your unit. Refer to suggested location of the strap as per the diagram and follow recommendations on the notice included into the bag of item 20-HH510.

Cher client, **pour votre propre sécurité** veuillez utiliser cette courroie afin d'assurer l'équilibre de votre meuble. Référez-vous au schéma afin de finaliser l'installation de l'attache et suivez les recommandations inscrites sur le feuillet inclus dans le sac de l'attache 20-HH510.

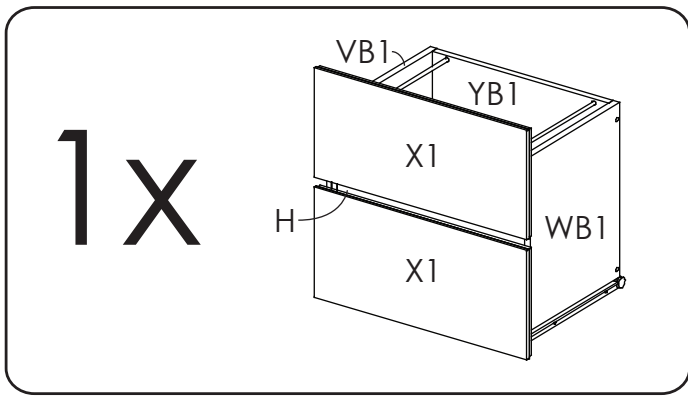

**07** ↓ 2x VB1 - WB1

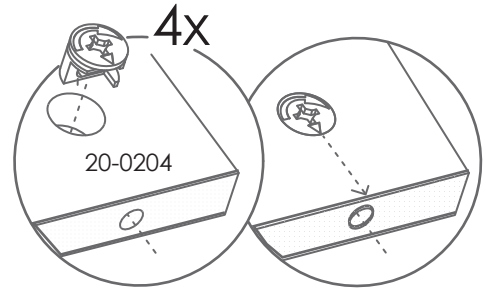

**08**

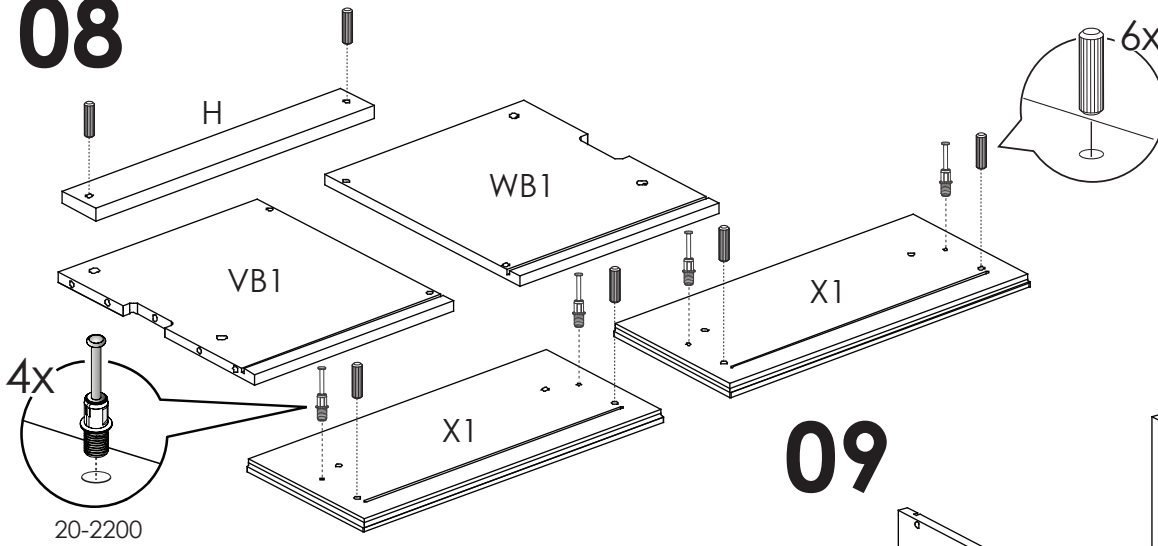

**09**

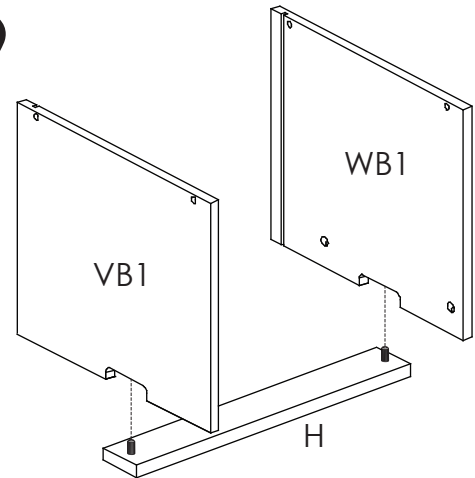

**10**

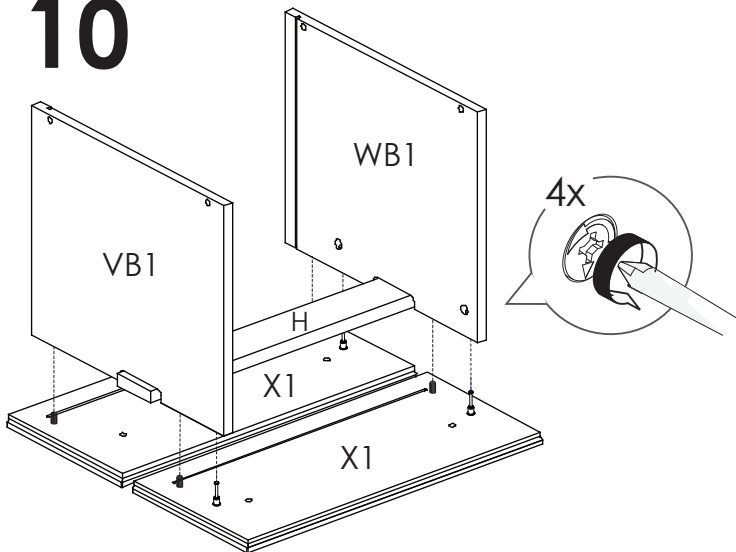

**11**

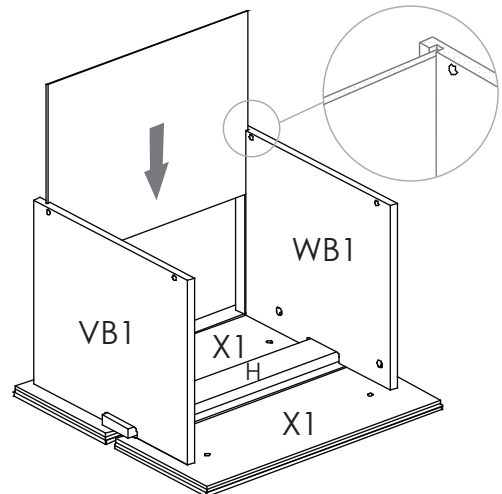

# 12

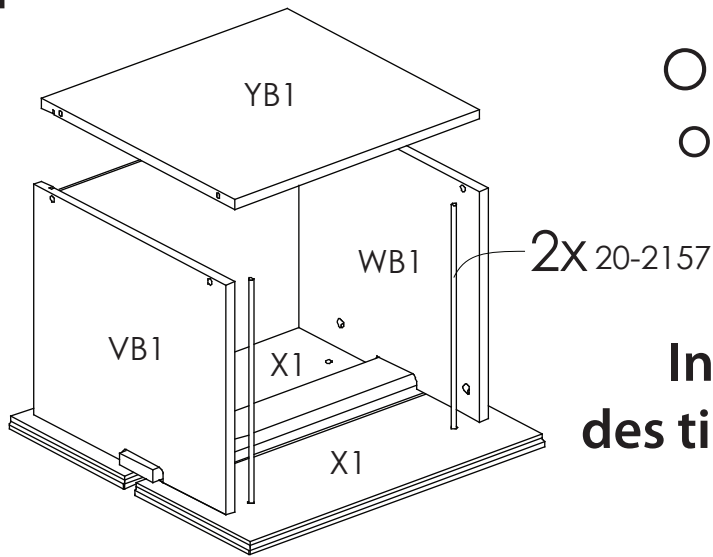

Optionnal installation  
of filing rods 20-2157

**Installation optionnelle  
des tiges pour filières 20-2157**

# 13

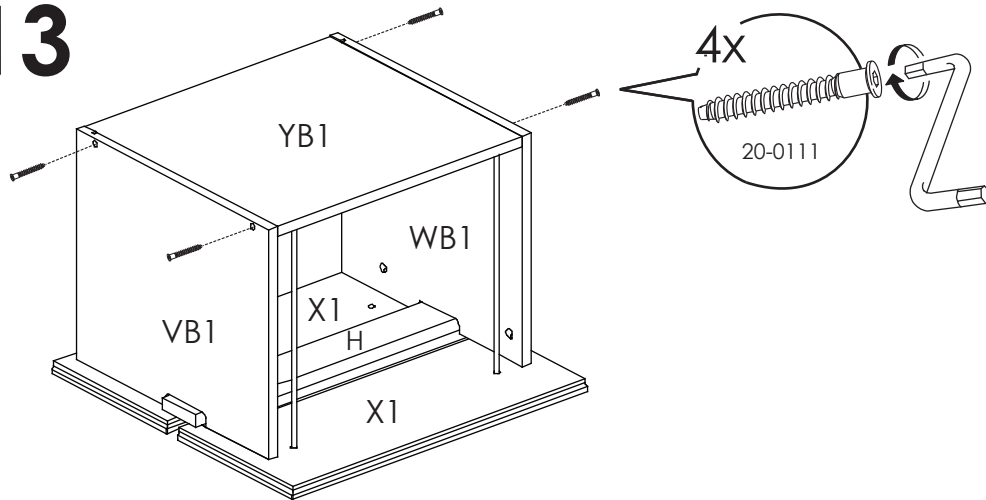

# 14

Align at the front.  
Drawer slide will  
overlap at the back.

**Appuyez la coulisse à  
l'avant sur la façade.  
elle dépassera à l'arrière.**

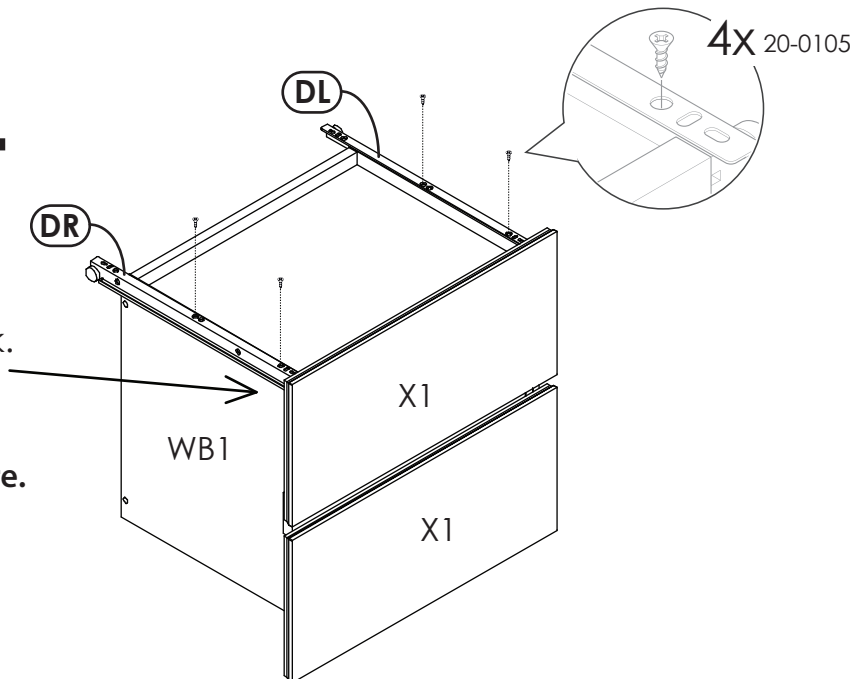

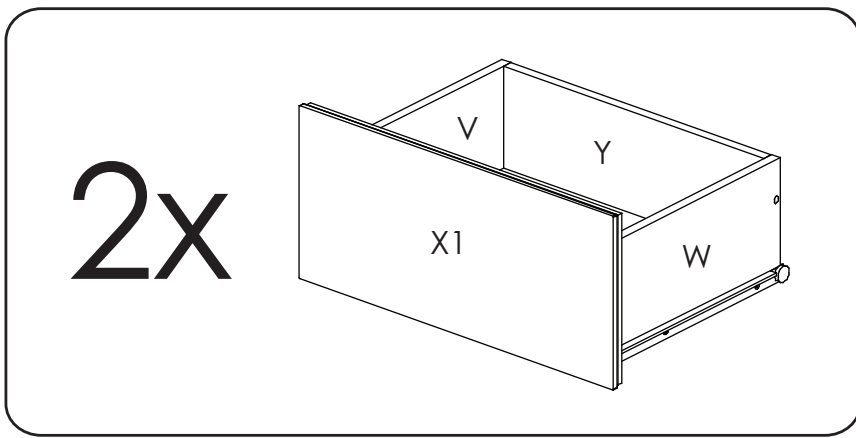

**15** ↓ 2x V - W

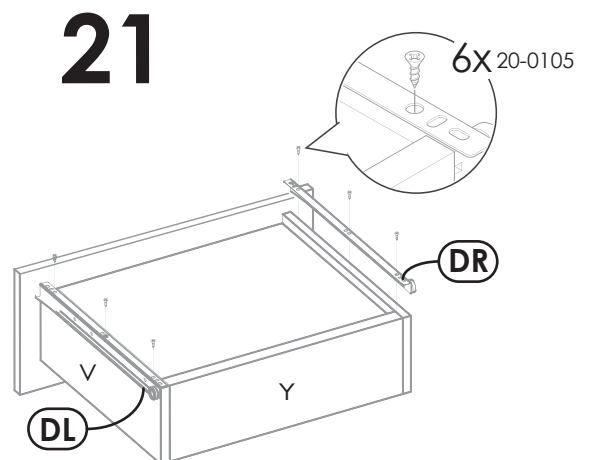
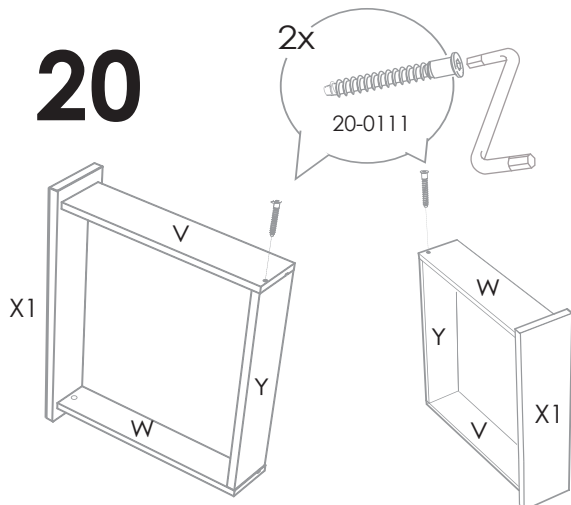
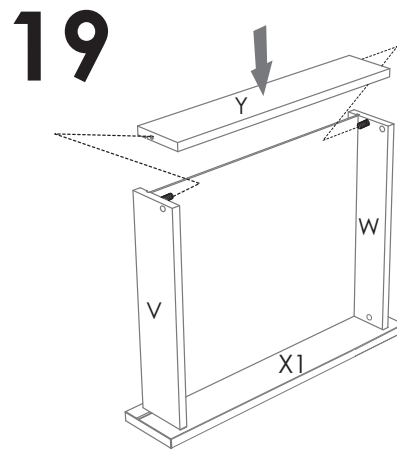
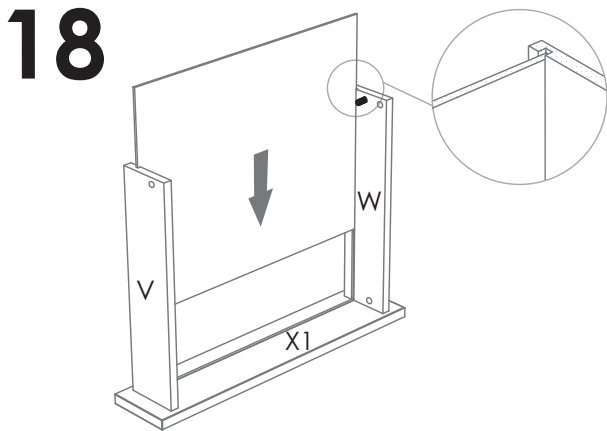
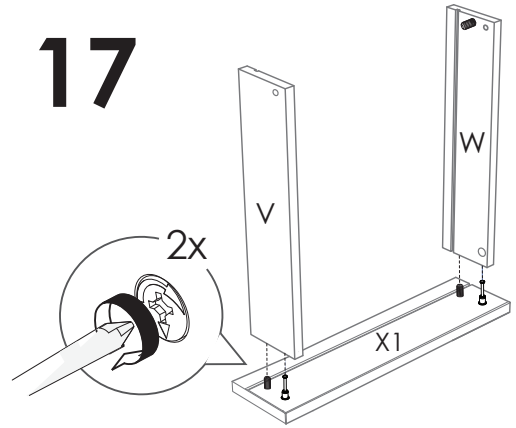
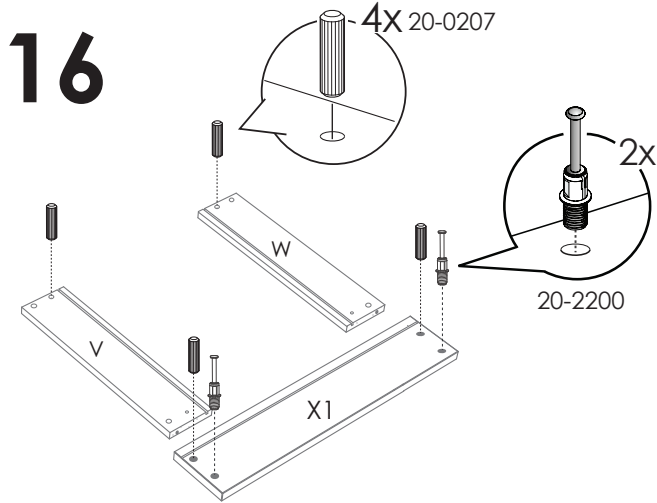
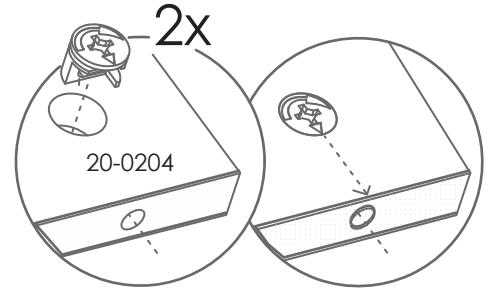



# Units Assembly *Assemblage des unités*

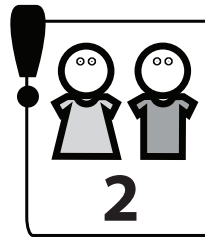

Attach to the wall with proper anchor device (not included)

Attachez au mur en utilisant une fixation appropriée (non incluse)

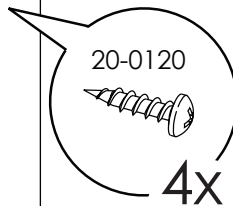
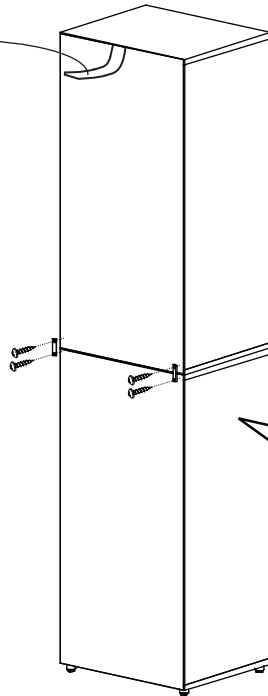
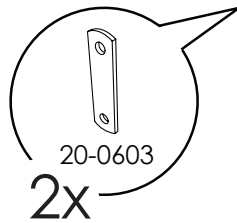

## Group of 2 units *Ensemble de 2 unités*

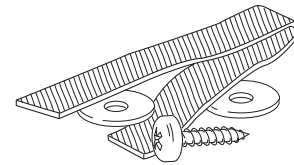

20-HH510

### Safety *Sécurité*



Dear customer. **For your own safety**, please use this hold-on device to secure the equilibrium of your unit. Refer to suggested location of the strap as per the diagram and follow recommendations on the package.

Cher client. **Pour votre propre sécurité**, veuillez utiliser cette courroie afin d'assurer l'équilibre de votre meuble. Référez-vous au schéma afin de finaliser l'installation de l'attache et suivez les recommandations inscrites sur le feuillet

## Rear view *Vue arrière*

Attach to the wall with proper anchor device (not included)

Attachez au mur en utilisant une fixation appropriée (non incluse)

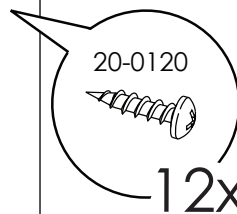
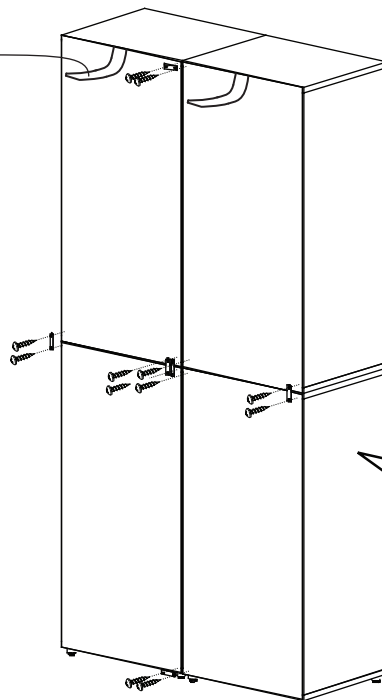
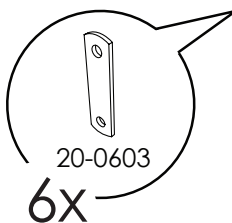

## Group of 4 units *Ensemble de 4 unités*

## Limited 1 Year Warranty

All Nexera products are warranted to the original purchaser against defects in material or workmanship for a period of 1 year from the date of purchase.

“Defects” as used in this warranty is defined as any imperfections that may impair the use of the furniture or product for which it was intended to.

This warranty is expressly limited to the replacement of defective furniture parts and/or components, subject to availability of stock. Assembly labor is excluded.

This warranty applies under conditions of normal use. It does not cover defects caused by improper assembly or disassembly, product modification, intentional damage, abuse, misuse, accidents, negligence or exposure to the elements. Our furniture products are not intended for outdoor use.

This warranty is only applicable in Canada and the USA.

Nexera reserves the right to request proof of purchase from an authorized retailer as well as any other proofs to document a warranty claim.

This warranty is explicit on the limits of Nexera liability and entitles the original purchaser to specific rights. Any warranty defined by law in your state/province is limited to 1 year. Should the law in your state or province differ from the above, it will not apply.

## Garantie limitée de 1 an

Tous les produits Nexera sont garantis à l'acheteur original contre toutes défectuosités de matériel ou de fabrication pour une période de 1 an à partir de la date d'achat.

Le mot “défectuosités” utilisé dans cette garantie signifie toutes imperfections pouvant nuire à l'utilisation du meuble ou du produit pour lequel il a été conçu.

Cette garantie est expressément limitée au remplacement des pièces ou composantes défectueuses, sujet à la disponibilité des stocks. La main d'œuvre de l'assemblage est exclue.

Cette garantie s'applique dans des conditions d'utilisation normales. Elle ne couvre pas des défectuosités résultant d'un assemblage ou désassemblage défaillant, modification du produit, dommages intentionnels, abus, usage impropre, accidents, négligence ou des expositions aux éléments extérieurs. Nos meubles ne sont pas destinés pour une utilisation à l'extérieur.

Cette garantie s'applique uniquement au Canada et aux États-Unis.

Nexera se réserve le droit d'exiger une preuve d'achat ou toutes autres pièces justificatives pour valider cette garantie.

Cette garantie est limitative quant à la responsabilité de Nexera et donne à l'acheteur original des droits spécifiques. Toute garantie législative prévalant dans votre lieu de résidence est limitée à une période de 1 an. Advenant le cas que la législation de votre lieu de résidence diffère de celle-ci, elle ne s'applique s'appliquera pas.

## Garantía limitada de 1 año

Nexera garantiza todos sus productos contra defectos en materiales y mano de obra por un periodo de 1 año a partir de la fecha original de la compra.

Para efectos de esta garantía, “defecto” significa toda imperfección que puede perjudicar el uso del mueble o el producto para el que fue concebido.

Esta garantía se limita expresamente al reemplazo de las partes defectuosas o sus componentes, según las disponibilidades. No incluye la mano de obra del ensamblaje.

Esta garantía se aplica en condiciones de uso normal. No cubre los defectos causados por ensamblaje o desensamblaje inapropiados, modificación del producto, daño intencional, abuso, mal uso, accidente, negligencia o exposición a elementos exteriores. Nuestros productos no deben usarse al exterior.

Esta garantía se aplica únicamente en Canadá y Estados Unidos.

Nexera se reserva el derecho de exigir pruebas de compra al vendedor autorizado o toda otra prueba para validar esta garantía.

Esta garantía es explícita en cuanto a las limitaciones de responsabilidad de Nexera y otorga al comprador original derechos específicos. Toda garantía jurídica en su provincia o estado de residencia se a 1 año. En caso de que las leyes provinciales o estatales difieran, la garantía no se aplicará.

nexera  
www.nexeradistribution.com