



### Features

- Pure acrylic construction
  - All-in-one combo
  - Classic design with a modern touch
  - High comfortable backrest
  - Free-standing installation
  - Chrome faucet and accessories
  - Easy to clean
- ❖ Faucet with handheld shower included
  - ❖ Drain/overflow kit included
  - ❖ CUPC certified (under CSA B45 standards)

### Caractéristiques

- Construction 100% acrylique
  - Ensemble Tout-en-un
  - Design classique au lignes moderne
  - Dossier haut confortable
  - Installation autoportante
  - Robinetterie et accessoires chromés
  - Entretien facile
- ❖ Robinet avec douchette a main inclus
  - ❖ Trop-plein et drain inclus
  - ❖ Certifié CUPC (standards CSA B45)

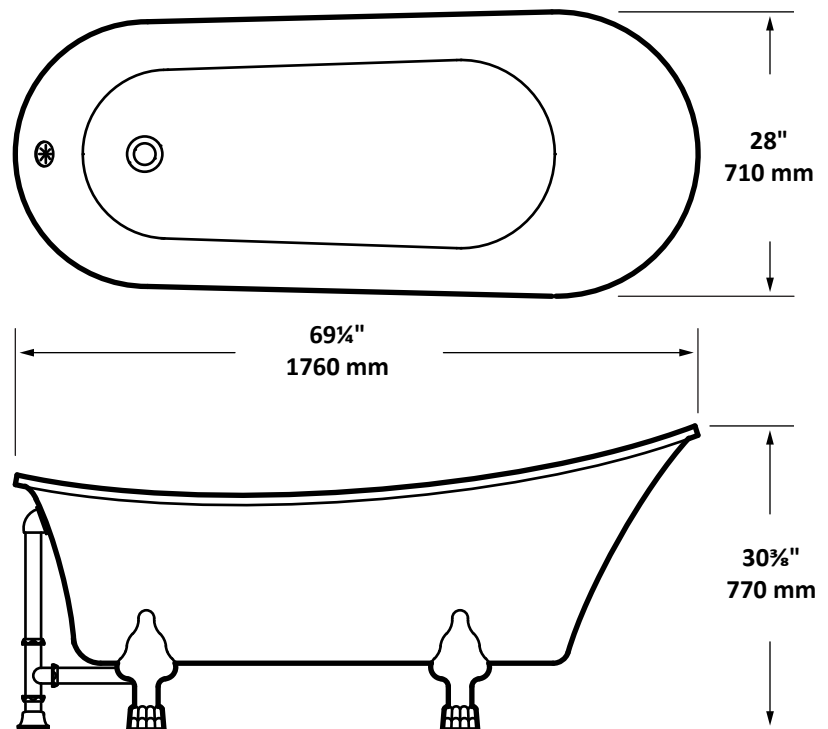

Approx. Weight / Poids : 105 lb ( 48 kg)