

**ZH2023 Bench – Grey linen**  
**ZH2023 Bench – Oatmeal linen**  
**ZH2023 Bench – White linen**  
**Assembly Instructions**

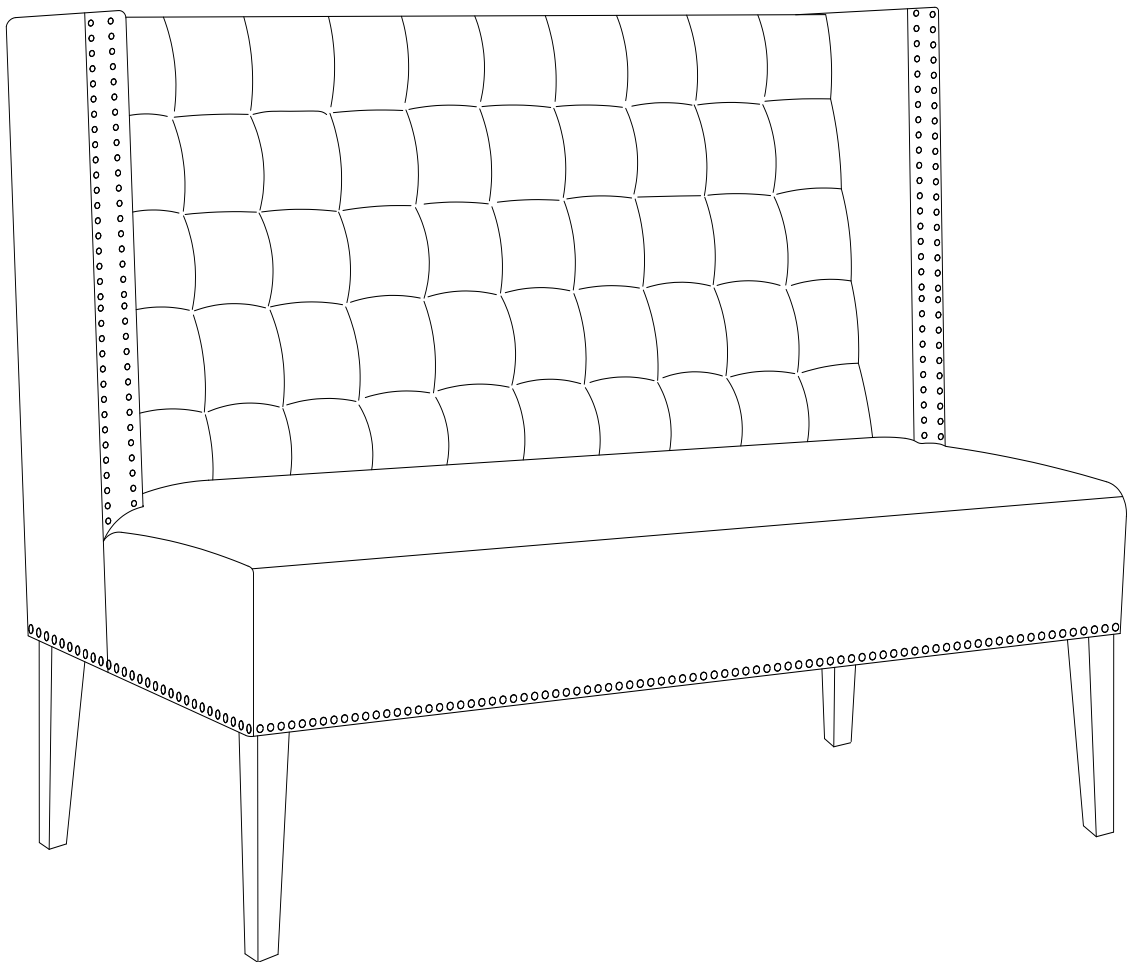





For assistance with assembly contact:  
Wayfair Customer Service,  
877-WAYFAIR (877-929-3247)  
[www.wayfair.com](http://www.wayfair.com)

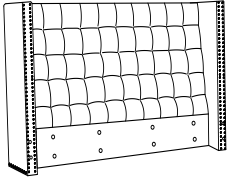

# ZH2023 Bench Parts List

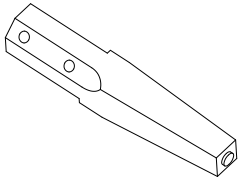
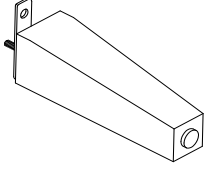
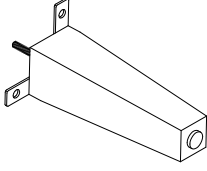
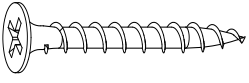
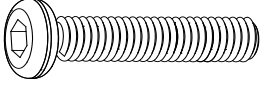
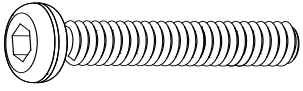
Before beginning assembly, separate all parts and carefully study the parts diagrams below.  
Review all parts and hardware before disposing of any packaging.  
You may receive extra hardware with your unit.  
Call Customer Service for missing hardware.

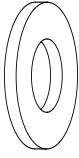
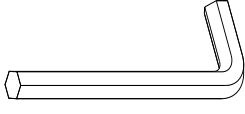
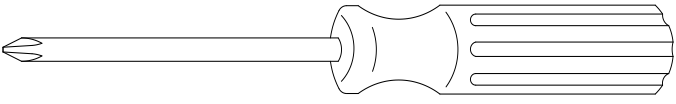
<b>A</b>  <b>Back panel</b> <b>Quantity of 1</b>	<b>B</b>  <b>Seat</b> <b>Quantity of 1</b>
<b>C</b>  <b>Front legs</b> <b>Quantity of 2</b>	<b>D</b>  <b>Left back leg</b> <b>Quantity of 1</b>
<b>E</b>  <b>Right back leg</b> <b>Quantity of 1</b>	
<b>1</b>  <b>Screw Dia 8mm*1"L</b> <b>Quantity of 4</b>	<b>2</b>  <b>Bolt: Dia 5/16" * 2" L</b> <b>Quantity of 10</b>
<b>3</b>  <b>Bolt: Dia 5/16" * 2-1/2" L</b> <b>Quantity of 4</b>	<b>4</b>  <b>Spring washer</b> <b>Quantity of 14</b>
<b>5</b>  <b>Flat washer</b> <b>Quantity of 14</b>	<b>6</b>  <b>Allen wrench</b> <b>Quantity of 1</b>
<b>Care and Cleaning Instructions:</b> Please see care and cleaning label attached to bottom of chair seat.	For replacement parts or questions, please call Customer Service at 877-WAYFAIR (877-929-3247)
<b>Assembly Tool Required No.2 Phillips Screwdriver (Not included)</b>	

# ZH2023 Bench Assembly Instructions

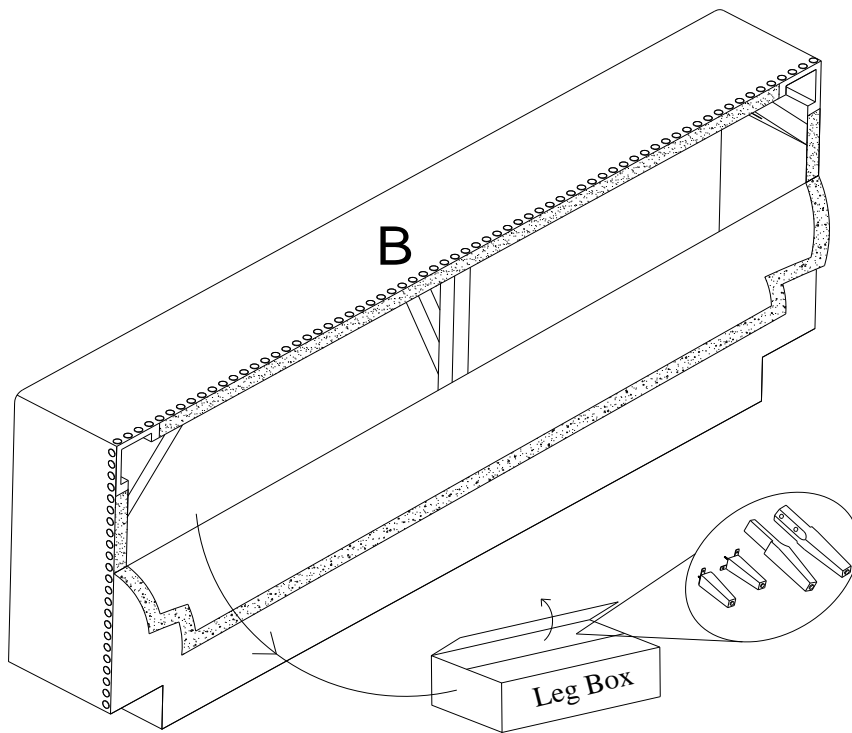
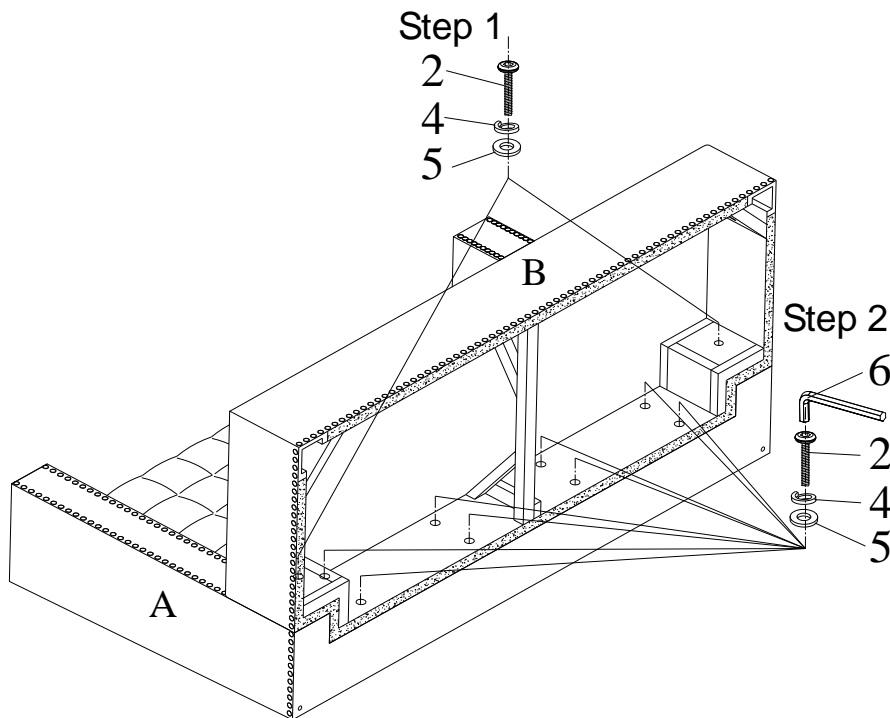

**Figure 1**

Unpack and lay parts on clean, padded surface like carpet or blanket. Check that you have all parts indicated on the front page.

Lift the Velcro strip from the bottom of the seat (B) and take out the leg box which includes 2 front legs and 2 back legs.

Open the legs box and take out the legs.



**Figure 2**

Attach seat (Part B) to back (Part A) by bolts (2), spring washers (4) and flat washers (5). Don't tighten bolts until all bolts are in place. Tighten bolts (2) by using Allen wrench (6) as shown in Figure 2.

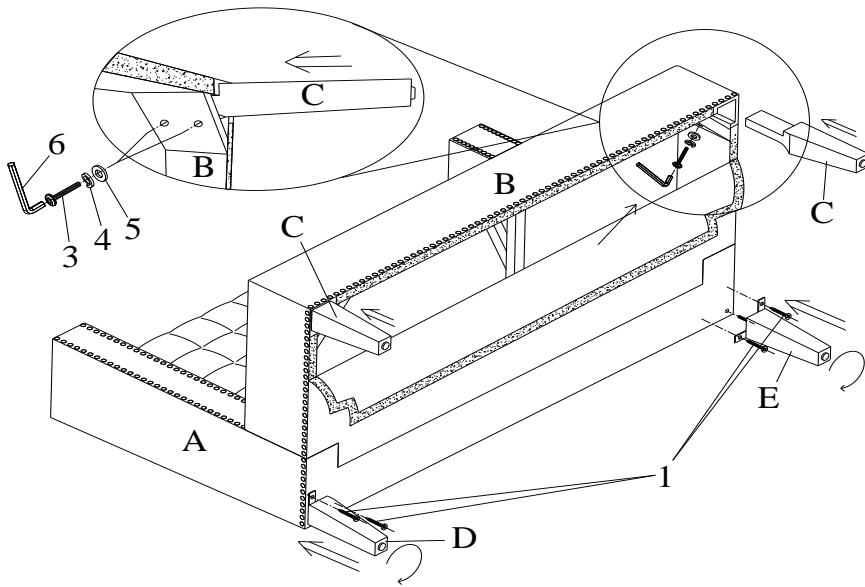

Attach left back leg (part D) and right back leg (part E) into the seat (A)'s pre-drilled holes, turning left back leg (part D)/right back leg (part E) by hand as shown in Figure 3.

Tighten left back leg (part D)/right back leg (part E)'s by Screw (1) with Phillips screwdriver (not included) as shown in figure 3.

Attach the front legs (Part C) to the seat (A)'s pre-drilled holes.

Insert bolt (2), spring washers (4) and flat washers (5) into pre-drilled holes, tighten bolt (2) by Allen wrench (6) as shown in figure 3.

**Figure 3**

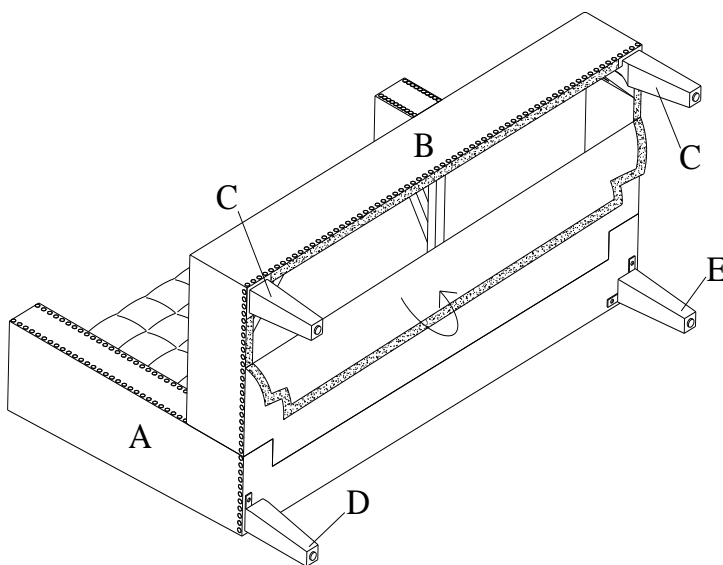

Close Velcro strip on the bottom of seat (A).

**Figure 4**

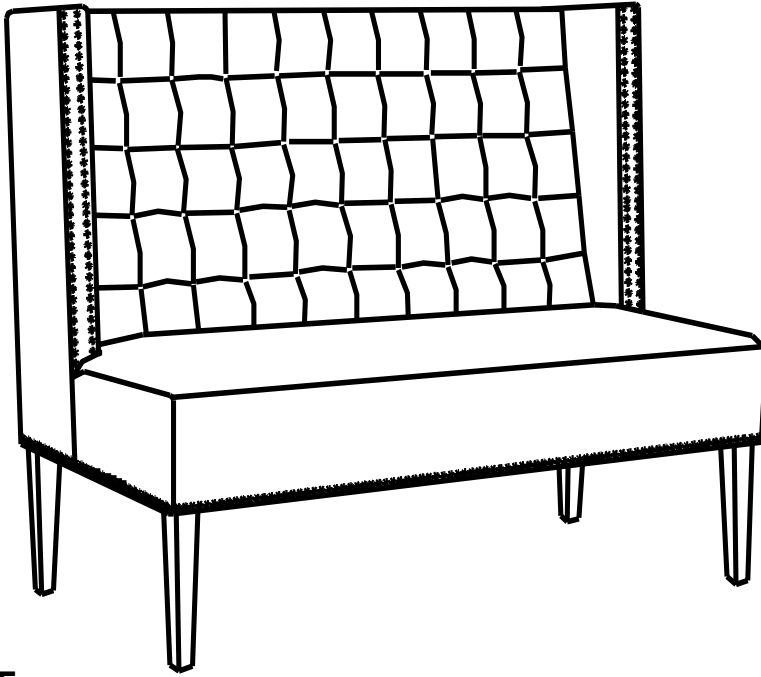

**Figure 5**

Turn over the bench,  
Now your bench is ready to use!