













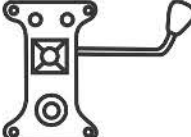

**ATTENTION: USING WRONG SCREWS WILL CAUSE DAMAGE TO THE PRODUCT.
DO NOT TIGHTEN ANY SCREWS UNTIL ALL ARE IN PLACE**

(A) BACK REST X 1 	(G) CASTERS X 5 
(B) SEAT X 1 	(H) GAS LIFT COVERS X 1 SET 
(CL) X1 LEFT ARM 	(I) ARM CAPS X 8 
(CR) X1 RIGHT ARM 	(J) 6x30mm X2 
(D) MECHANISM X 1 	(K) 6x20mm X2 
(E) GAS LIFT X 1 	(L) 8x30mm x8 
(F) BASE X 1 	(M) TOOL X 1 

① Make sure the casters have the rings, and insert into base using pressure. Place the gas lift over the base, and the gas lift covers over the gas lift.

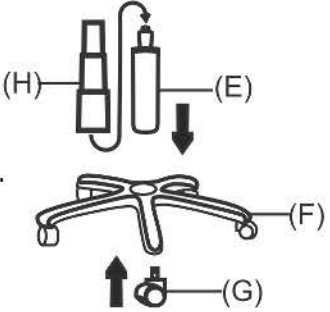

③ Attach the left arm (CL) to the seat and back using screws L. Do not tighten any of these screws yet.

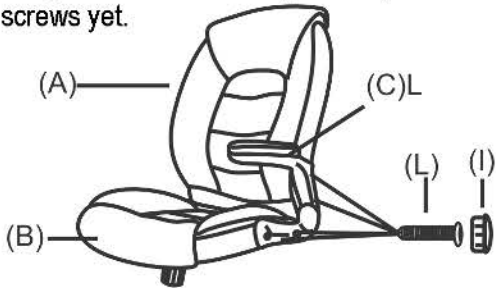

⑤ Carefully place the top of the chair over the bottom, making sure the tip of the gas lift engages inside the mechanism. The chair will stay together by friction and pressure after using it.



② Attach the mechanism to the bottom of the seat, using 2 screws K at front, 2 screws J at back.

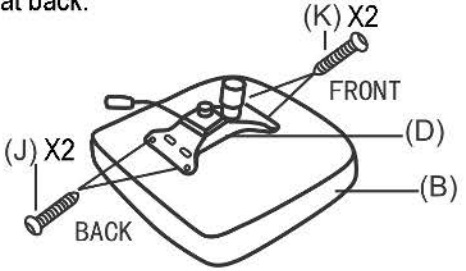

④ Attach the right arm (CL) to the seat and back using screws L. Proceed to tighten the screws on both arms. Place the arm covers.

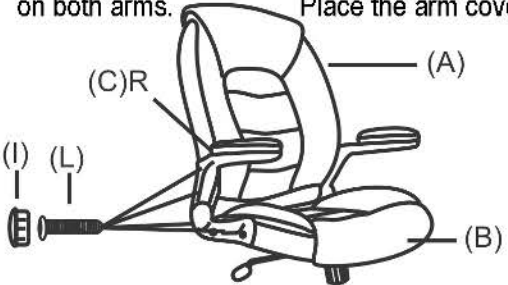

⑥ SEE NOTES FOR LIFT AND TILT FUNCTIONS



LIFT AND TILT FUNCTIONS:

[*] To raise and lower the chair: Pull the handle UP with force. The chair will go down while sitting on it, or up if you lift your body.

[*] Back tilt mechanism: Pull handle OUT to unlock, and push handle IN to lock this feature.

[**] Tilt tension control: Turn knob CLOCKWISE to apply more tension or COUNTERCLOCKWISE to release the tension.

RTA-734H

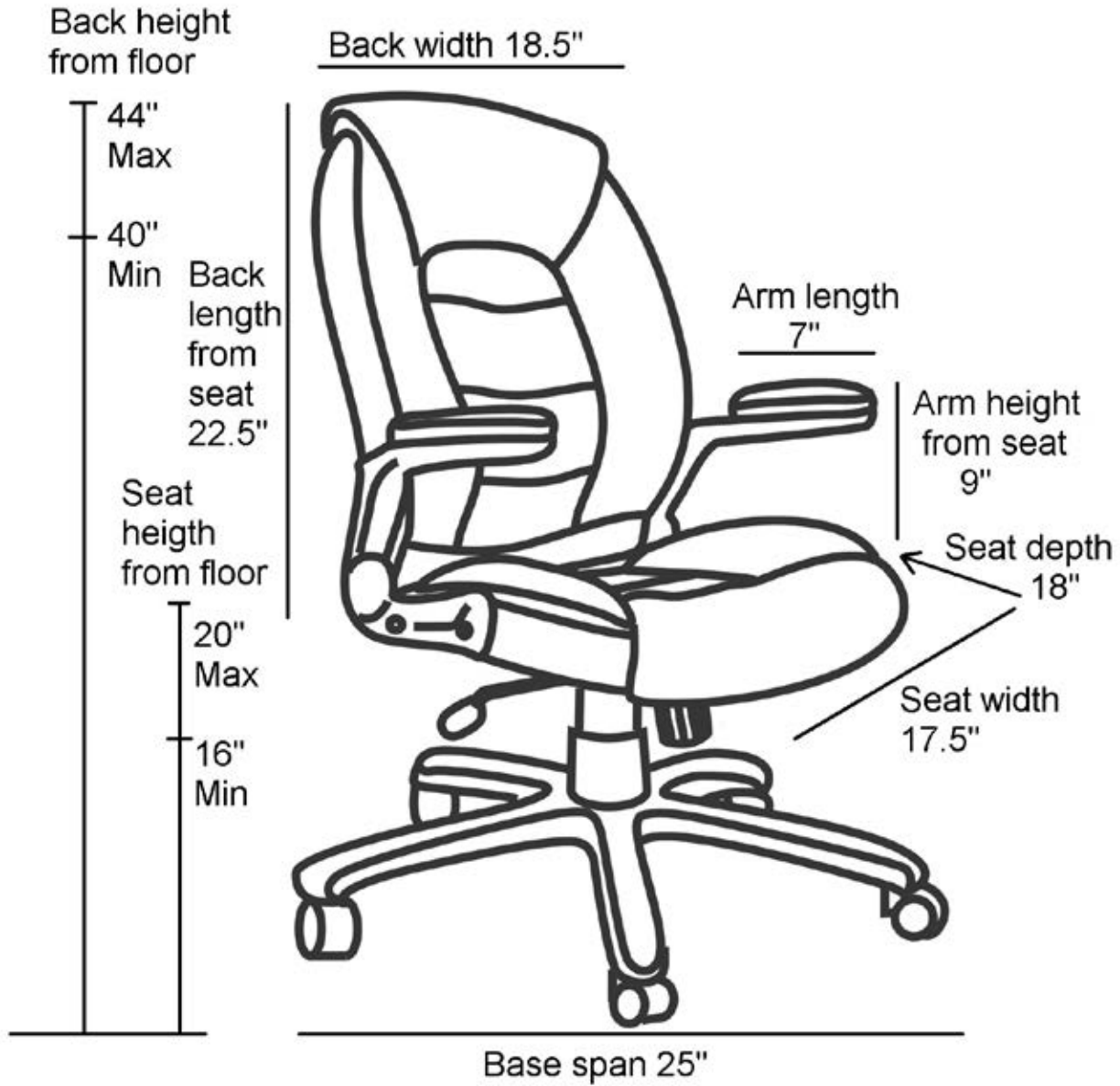

MAXIMUM WEIGHT CAPACITY: 200 LBS



PRODUCT WARRANTY

TECHNI MOBILI DESK WARRANTY

LIMITED 5-YEAR WARRANTY

RTA Products, LLC warrants to the Original Purchaser that this product will be free from defects in its workmanship and materials, under normal use and service conditions, as described herein. "Defects" as used in this warranty, is defined as any imperfections that impair the use of the furniture or product. RTA products will repair or replace, at its option, without charge to the original purchaser 'other than freight from purchaser to RTA Products, only the defective products or parts for a period of FIVE (5) Years.

Replacement parts can only be supplied if parts are available. Items out of production may be unavailable. This warranty will be effective for the applicable time period beginning the date of purchase on your original sales receipt. RTA product's obligation under this warranty is limited to repairing or replacing products or parts as provided herein. This product has been designed for and is intended for office and home-office use only. This warranty is Original Purchaser's sole remedy for product defects, and this warranty does not extend to any product, or damage to any product, caused by or attributed to abuse or misuse, products used for commercial or rental purposes, use modifications of, or attachments to the product, and products or parts not used, maintained, or extended hereunder is in lieu of any and all other warranties, express or implied, including without limitations any implied warranty or merchantability or of fitness for a particular purpose. Please note, all desks made with PVC Laminate surface should not be exposed to direct sunlight, as it may damage the material. Damage of this nature is not covered under this warranty.

RTA Products will not be responsible for indirect, special, incidental or consequential damages. This warranty is limited to merchandise purchased in the Continental United States. Some States do not allow the exclusion or limitation of incidental or consequential damages, so the above limitations or exclusions may not apply to you. This warranty gives you specific legal rights. You may also have other rights that may vary from state to state.

RTA Products will advise you of the procedure to follow in making warranty claims. The following are the procedures for warranty claims:

- a. Call us Monday – Friday, from 9am-5pm (Eastern Time) at (866) 782-8262 to explain the defect and give your name, address and phone number. Please have ready the model number of our product, date and place of purchase. You can also write to us by e-mail to warranty@rtaproducts.com and include the same information.
- b. If we determine that replacement will remedy the situation, and in order to determine the extent or the cause of the defect, purchaser will need to send the part in question at purchaser's expense. Once we receive the part, we will examine it and determine whether the claim is valid (or not), and then proceed to send the replacement. We will ship the replacement at our expense.

TECHNI MOBILI CHAIR WARRANTY

2-YEAR WARRANTY

1. RTA Products, LLC has warranted the Techni Mobili office chairs to the original purchaser who acquired a new product from RTA Products or its authorized resellers of the product against defects in material or workmanship.
2. This warranty is expressly limited to the repair or replacement (at its option) of defective chair components or materials that fails under normal use as a result of a defect in materials or workmanship. This warranty is limited to merchandise purchased in the Continental United States. No assembly labor is included. The word "defects" as used in this warranty, is defined as imperfections that impair the utility of the product.
3. This warranty applies under conditions of normal use, but does not apply to defects that result from intentional damage, negligence, unreasonable use or exposure.
4. Liability for consequential damages is excluded to the extent exclusion is permitted by law. This warranty gives you specific legal rights, and you may have other rights that vary from State to State.
5. RTA Products does not warrant: a) natural variations in character marks b) changes in surface finishes due to aging or exposure to light c) marks, scars, or wrinkles occurring naturally in leather d) failure resulting from normal wear and tear e) the matching of colors, grains, or textures of natural materials f) the colorfastness or the matching of textiles, including an exact match to cuttings or to swatch cards g) damage, marking, or staining of veneer surfaces due to contact with rubber or similar compounds, damage from sharp objects or imprinting from writing instruments, or prolonged exposure to direct sunlight h) we do not warrant products that are exposed to extreme environmental conditions or that have been subject to improper storage.
6. RTA Products shall not be liable for loss of time, inconvenience, commercial loss, or incidental or consequential damages.

7. Any modification to the original product voids the warranty. We do not warrant the performance of the product when used in combination with other than original products.
8. This product has been designed for and is intended for office and home-office use only. This warranty is Original Purchaser's sole remedy for product defects, and this warranty does not extend to any product, or damage to any product, caused by or attributed to abuse or misuse, products used for commercial or rental purposes, use modifications of, or attachments to the product, and products or parts not used, maintained, or extended hereunder is in lieu of any and all other warranties, express or implied, including without limitations any implied warranty or merchantability or of fitness for a particular purpose.
9. Report any defects to RTA Products, LLC together with your sales receipt or other proof of purchase. If the chair is defective within the terms of the warranty, RTA Products, LLC will furnish a replacement chair (at its option) at no cost of equal or similar value and design.
10. RTA Products will advise you of the procedure to follow in making warranty claims. The following are the procedures for warranty claims:
 - a) Call us Monday – Friday, from 9am-5pm (Eastern Time) at (866) 782-8262 to explain the defect and give your name, address and phone number. Please have ready the model number of our product, date and place of purchase. You can also write to us by e-mail to warranty@rtaproducts.com and include the same information.
 - b) If we determine that replacement will remedy the situation, and in order to determine the extent or the cause of the defect, purchaser will need to send the part in question at purchaser's expense. Once we receive the part, we will examine it and determine whether the claim is valid (or not), and then proceed to send the replacement. We will ship the replacement at our expense.

2COOL PRODUCT WARRANTY

ONE (1) YEAR LIMITED WARRANTY

2COOL warrants this product against defects in materials and/or workmanship under normal use for a period of ONE (1) YEAR from the date of purchase by the original purchaser ("Warranty Period"). If a defect arises and a valid claim is received within the Warranty Period, at its option, 2COOL will either 1) repair the defect at no charge, using new or refurbished replacement parts, or 2) replace the product with a new product that is at least functionally equivalent to the original product.

Obtaining Service: To obtain warranty service, call 2COOL Limited Warranty Service at 1-866-782-8262. Please be prepared to describe the product that needs service and the nature of the problem. A purchase receipt is required. All repaired and replacements must be authorized in advance. Service options, parts availability and response times will vary. You are responsible for delivery and the cost of delivery of the product or any parts to the authorized service center for replacement, per our instructions.

Limits and Exclusions: Coverage under this Limited Warranty is limited to the Continental United States of America. This warranty does not apply to: a) damage caused by failure to follow instructions relating to the product's use or the installation of components; b) damage caused by accident, abuse, misuse, fire, floods, earthquake or other external causes; c) damage caused by service performed by anyone who is not a representative of 2COOL; d) accessories used in conjunction with a covered product; e) a product or part that has been modified to alter functionality or capability; f) items intended to be periodically replaced by the purchaser during the normal life of the product including, without limitation, batteries or light bulbs; g) any product sold "as is" including, without limitation, floor demonstration models and refurbished items; or h) a product that is used commercially or for a commercial purpose.

2COOL shall not be liable for incidental or consequential damages resulting from the use of this product, or arising out of any breach of this warranty. To the extent permitted by applicable law, 2COOL disclaims any and all statutory or implied warranties, including, without limitation, warranties of merchantability, fitness for a particular purpose and warranties against hidden or latent defects. If 2COOL cannot lawfully disclaim statutory or implied warranties, then to the extent permitted by law, all such warranties shall be limited in duration to the duration of this express warranty.

Some states disallow the exclusion or limitation of incidental or consequential damages or how long an implied warranty lasts, so the above exclusions or limitations may not apply to you. This warranty gives you specific legal rights and you may also have other rights, which vary from state to state.