

# DOREL ASIA

---

## TODDLER BED

**MODEL NO:**

WM3238C (Cherry)  
WM3238E (Espresso)  
WM3238W (White)

**UPC CODE:**

0-65857-15953-0 (Cherry)  
0-65857-15954-7 (Espresso)  
0-65857-15955-4 (White)

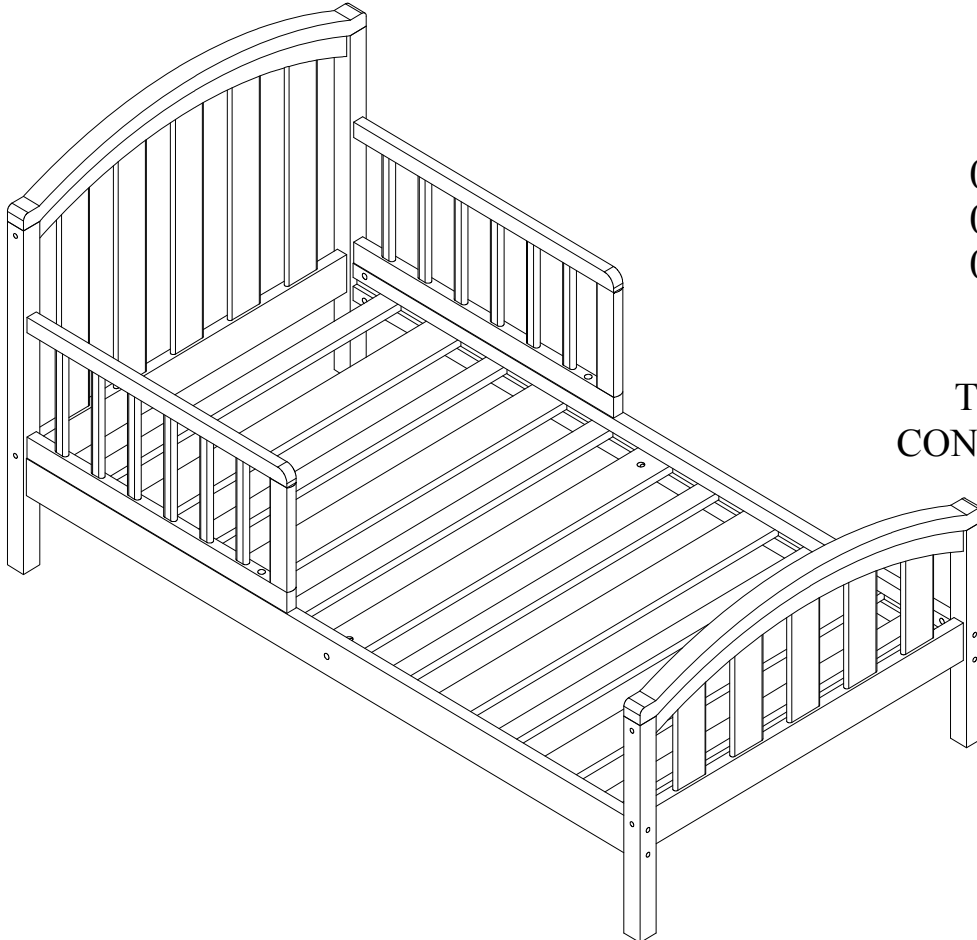

**NOTE:**  
THIS INSTRUCTION BOOKLET  
CONTAINS **IMPORTANT** SAFETY  
INFORMATION. PLEASE  
READ AND KEEP FOR  
FUTURE REFERENCE.

**Lot Number:**  
(TAKEN FROM CARTON)

\_\_\_\_\_

**DATE OF PURCHASE:**

\_\_\_\_\_ / \_\_\_\_\_ / \_\_\_\_\_

**DO NOT RETURN PRODUCT TO THE STORE.**

If a part is missing or damaged, Contact our  
customer service department. We will  
replace the part FREE of charge.



Tel # : 1-800-295-1980  
E-Mail: [das@dorel.com](mailto:das@dorel.com)  
Fax #: 514-353-7819

## CUSTOMER SERVICE

If you are missing parts or have any questions about this product, contact our customer service representative first!



**CALL 1-800-295-1980**

You can also order parts by writing to the address listed below. Please include the product model number, color and a detailed description of the part.

**Customer Service Department No. 413  
12345 Albert-Hudon Boulevard, Suite 100  
Montreal, Quebec  
Canada, H1G 3L1  
E-MAIL: [das@dorel.com](mailto:das@dorel.com)**



### **WARNING ENTRAPMENT/STRANGULATION HAZARD:**

- \* Infants have died in toddler beds from entrapment and strangulation.
- \* Failure to follow these warnings and assembly instructions could result in serious injury or death from entrapment or strangulation.
- \* NEVER use bed with children under 15 months.
- \* NEVER place bed near windows where cords from blinds or drapes may strangle a child.
- \* The TODDLER BED is not intended for children under 15 months of age or over 50 pounds (22.7kg).
- \* If guardrails are used as the mattress containment means, guardrail(s) provided must be used to avoid the formation of a gap between the mattress and the bed that could cause an entrapment.
- \* DO NOT place TODDLER BED near windows where cords from blinds or drapes may strangle a child.
- \* DO NOT place items with a string, cord, or ribbon around a child's neck, such as hood strings or pacifier cords.
- \* DO NOT suspend strings over a TODDLER BED for any reason.
- \* Any mattress used in this product must be at least 27-1/4 inches by 51-5/8 inches (69cm by 131cm) with a minimum thickness of 4 inches (10cm) and not exceeding 6 inches (15cm).
- \* Read all instructions before assembling crib. **KEEP INSTRUCTIONS FOR FUTURE USE.**
- \* Before each usage or assembly, inspect toddler bed for damaged hardware, loose joints, missing parts or sharp edges, DO NOT use toddler bed if any parts are missing or broken. Ask your dealer or write to our customer service representative (address & phone number shown above ) for replacement parts and instructional literature if needed. DO NOT substitute parts.
- \* **DO NOT** use a water mattress with this toddler bed.

### **NOTE**

- \* Phillips head screwdriver is not included.
- \* Assembly will require 2 people.
- \* Estimated assembly time: 25 minutes.
- \* **Caution:** Adult assembly required.

### CARE AND CLEANING

\* Dust regularly with a soft, lint-free cloth to prevent soil build-up. A damp cloth may be used occasionally to clean surface. Dry immediately. Do not use any abrasives that may damage finish. Excessive exposure to sunlight and extreme changes in temperature and moisture can damage wood furniture.

### MAINTENANCE

\* Check bolts periodically and tighten if necessary.

### LIMITED WARRANTY

Dorel Asia warrants its product to be free from defects in material and workmanship and agrees to remedy any such defect. This warranty covers 1 year from the date of original purchase. This warranty is valid only upon presentation of proof of purchase. This is solely limited to the repair or replacement of defective furniture components and no assembly labor is included. This warranty does not apply to any product which has been improperly assembled, subjected to misuse or abuse or which has been altered or repaired in any way. This warranty gives you specific legal rights and you may also have other rights which vary from State to State.



**WARNING: Should this product become damaged, and/or components are broken or missing, DO NOT USE.**

# TODDLER BED

WM3238C / WM3238E / WM3238W



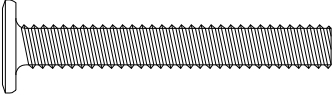
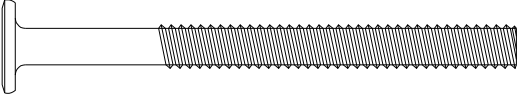
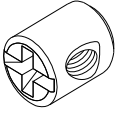
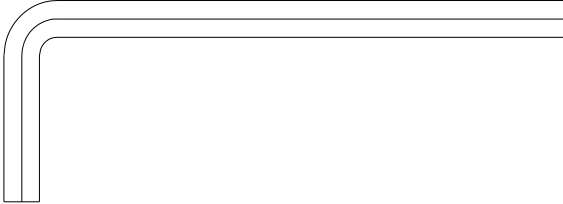
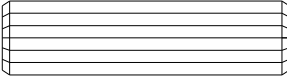
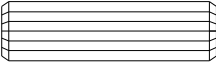
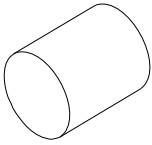

## HARDWARE LIST

<p><b>1</b></p>  <p>Ø1/4" x 1-3/4"</p>	<p><b>2</b></p>  <p>Ø1/4" x 2-3/4"</p>
<p>HEX SOCKET HEAD BOLT 2PCS</p>	<p>HEX SOCKET HEAD BOLT 22PCS</p>
<p><b>3</b></p>  <p>Ø1/4" x 1/2"</p>	<p><b>4</b></p>  <p>Ø4MM</p>
<p>BARREL NUT 10PCS</p>	<p>ALLEN KEY 1PC</p>
<p><b>5</b></p>  <p>Ø10mm x 40mm</p>	<p><b>6</b></p>  <p>Ø8mm x 30mm</p>
<p>WOOD DOWEL 4PCS</p>	<p>WOOD DOWEL 20PCS</p>
<p><b>7</b></p> 	
<p>STOPPER 10PCS</p>	

# TODDLER BED

WM3238C / WM3238E / WM3238W

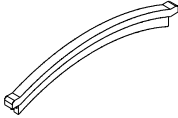
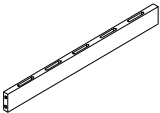
## PARTS LIST

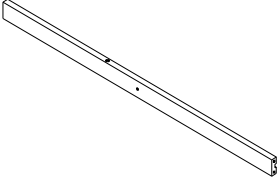
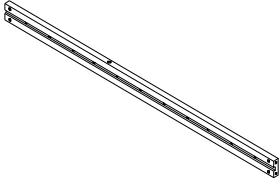
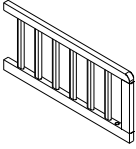
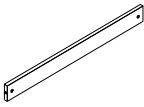
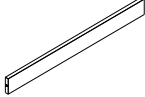
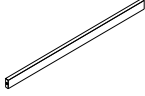
<p><b>A</b></p> 	<p><b>B</b></p> 	<p><b>C</b></p> 
<p>HEADBOARD POST 2 PCS</p>	<p>FOOTBOARD POST 2 PCS</p>	<p>TOP CROSS 2 PCS</p>
<p><b>D</b></p> 	<p><b>E</b></p> 	<p><b>F</b></p> 
<p>BOTTOM CROSS 2 PCS</p>	<p>HEADBOARD SLAT 5 PCS</p>	<p>FOOTBOARD SLAT 5 PCS</p>
<p><b>G</b></p> 	<p><b>H</b></p> 	<p><b>I</b></p> 
<p>LEFT SIDE RAIL 1PC</p>	<p>RIGHT SIDE RAIL 1PC</p>	<p>GUARDRAIL 2 PCS</p>
<p><b>J</b></p> 	<p><b>K</b></p> 	<p><b>L</b></p> 
<p>CENTER SUPPORT SLAT 1PC</p>	<p>WIDE SUPPORT SLAT 4PCS</p>	<p>NARROW SUPPORT SLAT 6PCS</p>

# TODDLER BED

## WM3238C / WM3238E / WM3238W

### STEP 1

Attach left headboard post (A) to the top cross (C) with hex socket head bolt (2) as shown. Insert headboard slats (E) into the holes of the top cross (C). Push the headboard slats to secure them in place.

Insert wood dowel (5) and stoppers (7) into the holes of the bottom cross (D) as shown. Insert the headboard slats (E) into the holes of the bottom cross (D) and secure to left headboard post (A) with hex socket head bolt (2). Insert wood dowel (5) into the end of the bottom cross (D). Attach the headboard post (A) to the top cross (C) and bottom cross (D) with wood dowels (5) and hex socket head bolts (2) as shown.

Use Allen key (4) to tighten all bolts installed.

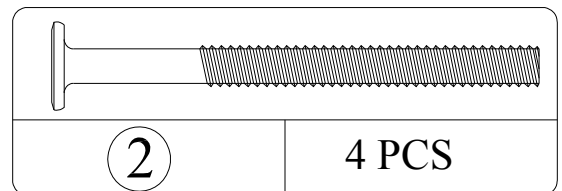
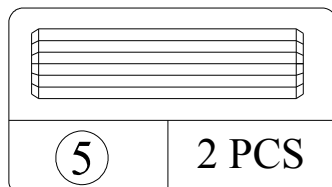
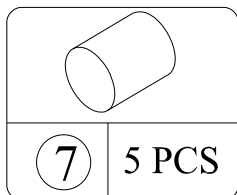
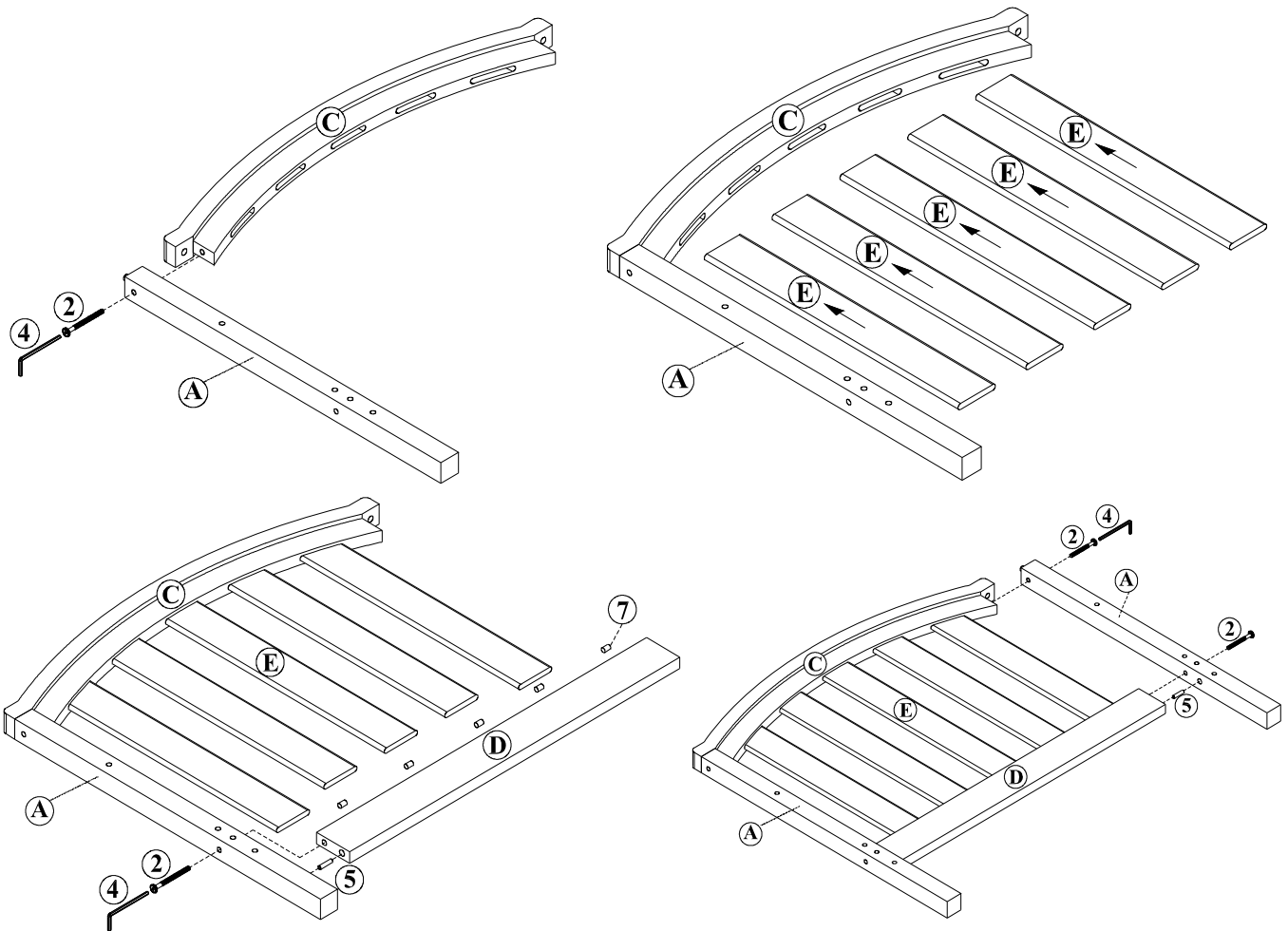

# TODDLER BED

## WM3238C / WM3238E / WM3238W

### STEP 2

Attach footboard post (B) to the top cross (C) with hex socket head bolt (2).  
 Insert footboard slats (F) into the holes of the top cross (C). Push the footboard slats to secure them in place.

Insert wood dowel (5) and stoppers (7) into the holes of the bottom cross (D).  
 Insert the footboard slats (F) into the holes of the bottom cross (D) and secure it to footboard post (B) with hex socket head bolt (2).  
 Attach the footboard post (B) to the top cross (C) and bottom cross (D) with wood dowel (5) and hex socket head bolts (2) as shown.

Use Allen key (4) to tighten all bolts installed.

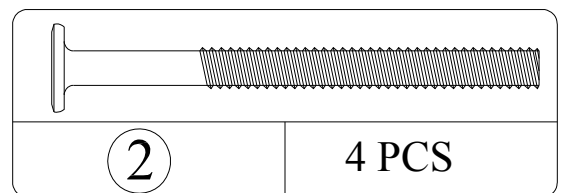
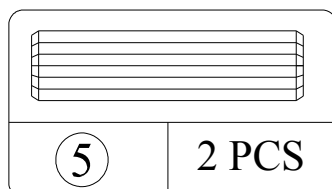
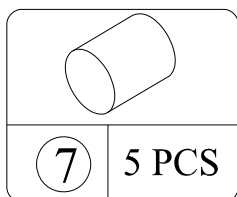
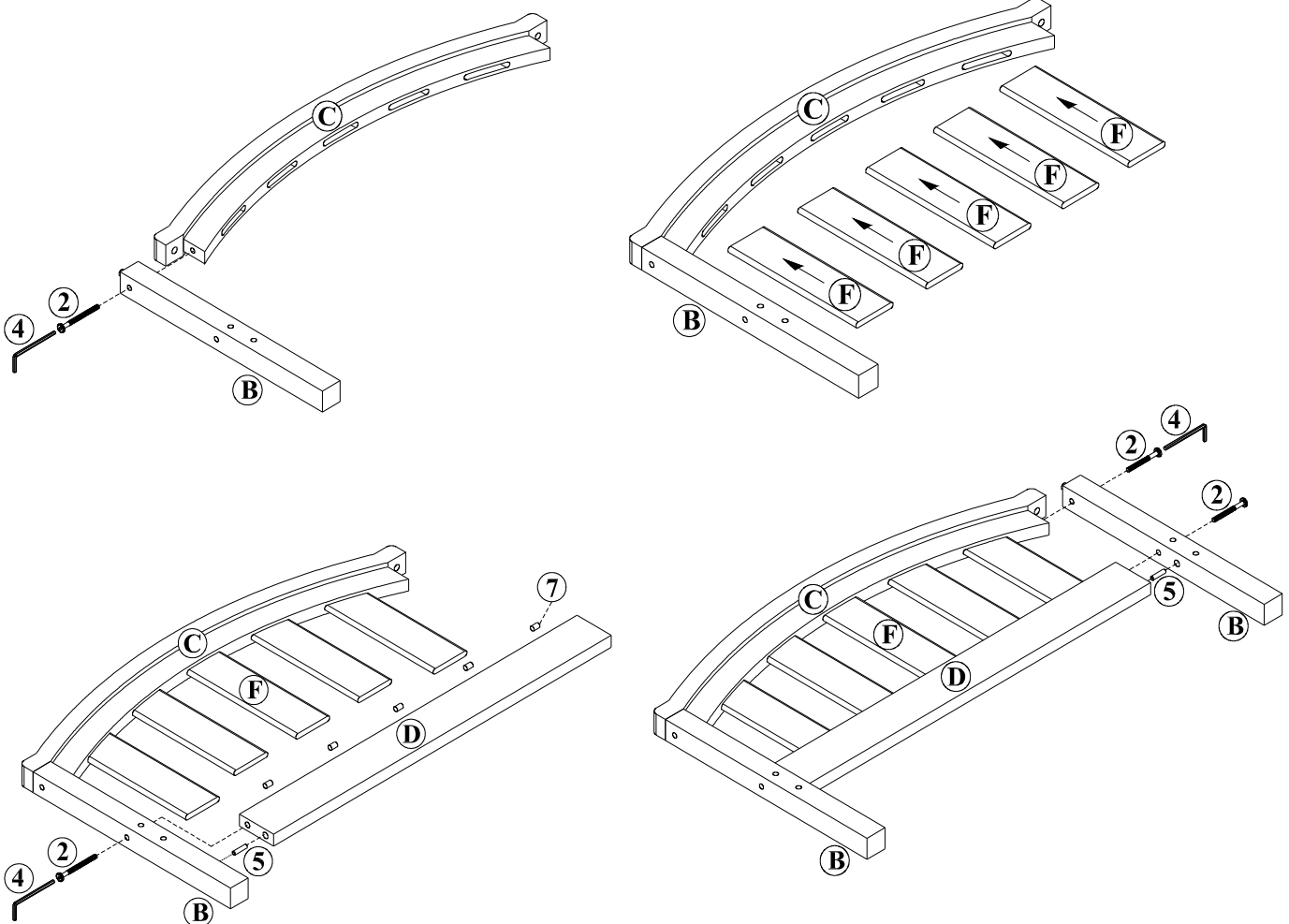

# TODDLER BED

## WM3238C / WM3238E / WM3238W

### STEP 3

Insert wood dowels (6) into the ends of the wide support slats (K) and narrow support slats (L) as shown.

Insert barrel nut (3) into the hole on the wide surface of center support slat (J). Ensure the barrel nut (3) is flush with center support slat (J).

Attach the center support slat (J) to the right side rail (H) by inserting hex socket head bolt (2) through the right side rail (H) and into the barrel nut (3). Use Allen key (4) to tighten the bolt.

NOTE: The barrel nut (3) can be rotated using a screwdriver (not included) to properly align with the bolt coming through the side rail.

Insert the wide support slats (K) and narrow support slats (L) into the grooves of the right side rail (H). Ensure the dowels in the slats go into the holes on the side rail.

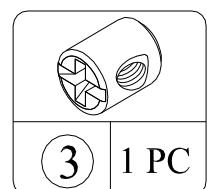
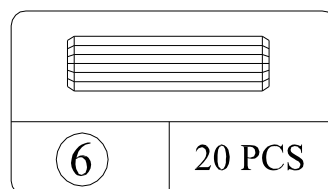
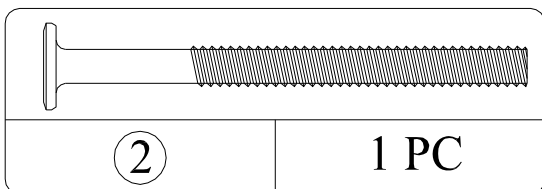
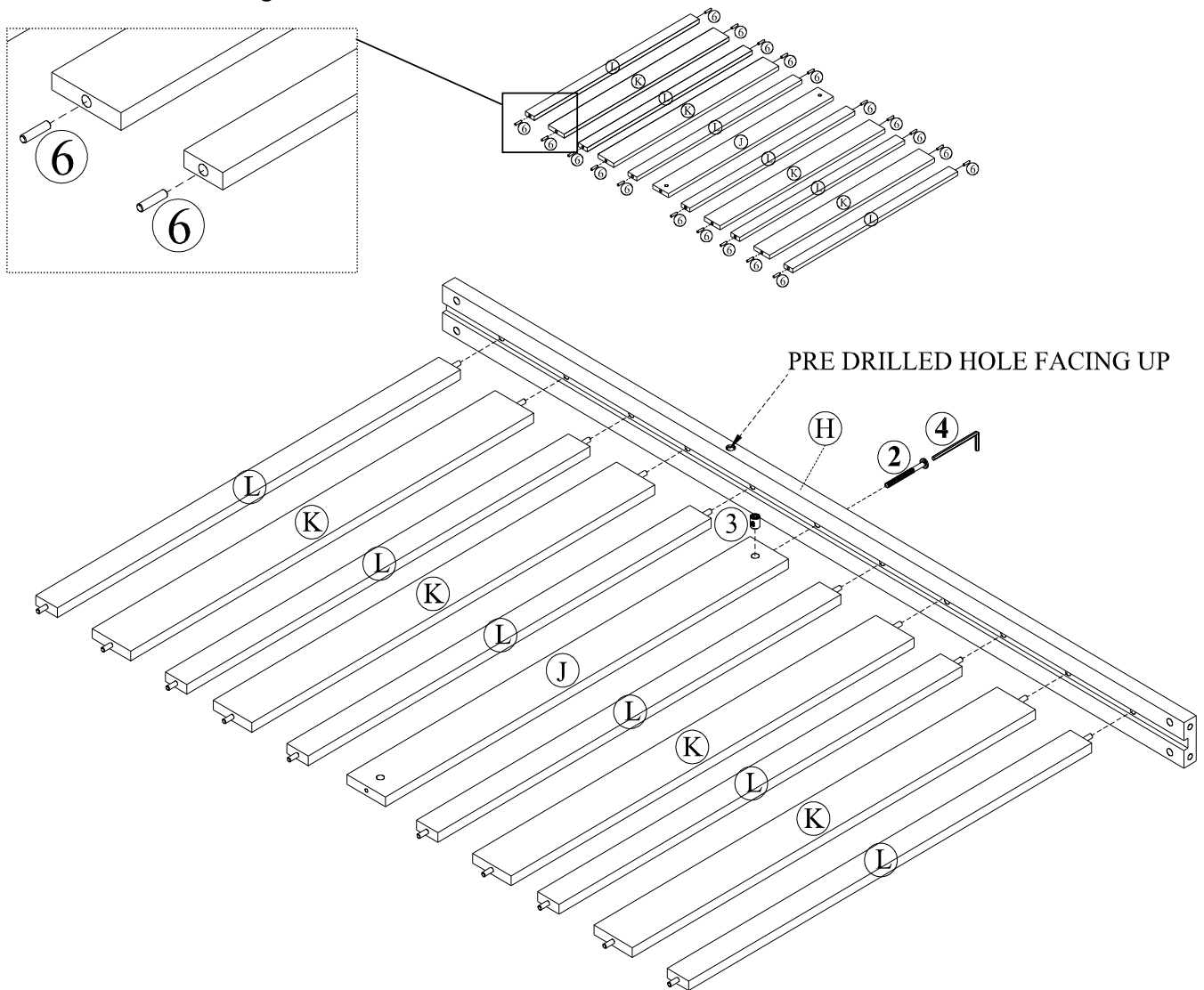



# TODDLER BED

## WM3238C / WM3238E / WM3238W

### STEP 4

Insert barrel nut (3) into the hole on the wide surface of center support slat (J). Ensure the barrel nut(3) is flush with center support slat (J).

Attach the left side rail (G) to the wide support slat (K) and narrow support slat (L).

Insert hex socket head bolt (2) through the left side rail (G) into the barrel nut (3) previously installed in wide support slat (J).

Use Allen key (4) to fully tighten the bolt.

NOTE: The barrel nut (3) can be rotated using a screwdriver (not included) to properly align with the bolt coming through the side rail.

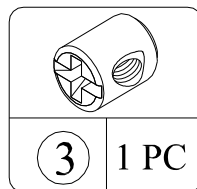
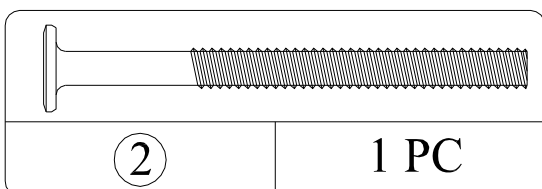
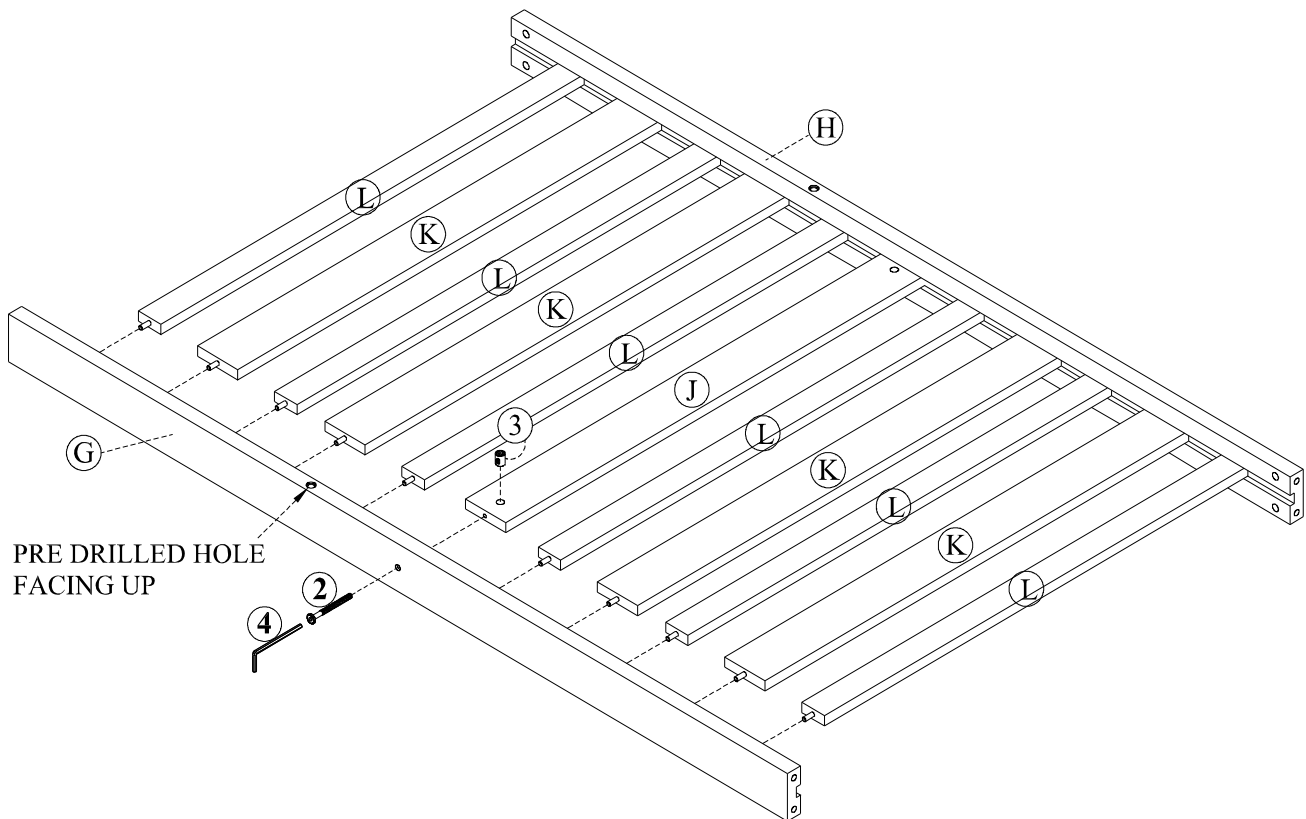

# TODDLER BED

## WM3238C / WM3238E / WM3238W

### STEP 5

Insert barrel nuts (3) into both ends of the left and right side rails (G & H).  
Attach the headboard and footboard to the left and right side rails (G & H) by threading hex socket head bolts (2) through the headboard posts (A) and footboard posts (B).  
Use Allen key (4) to install bolts.

NOTE: Do not fully tighten bolts. This will facilitate assembly in the following steps.

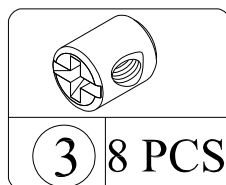
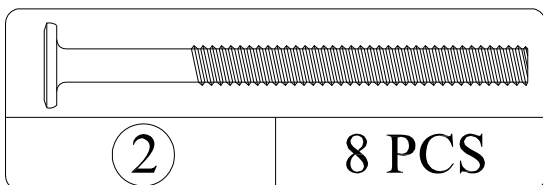
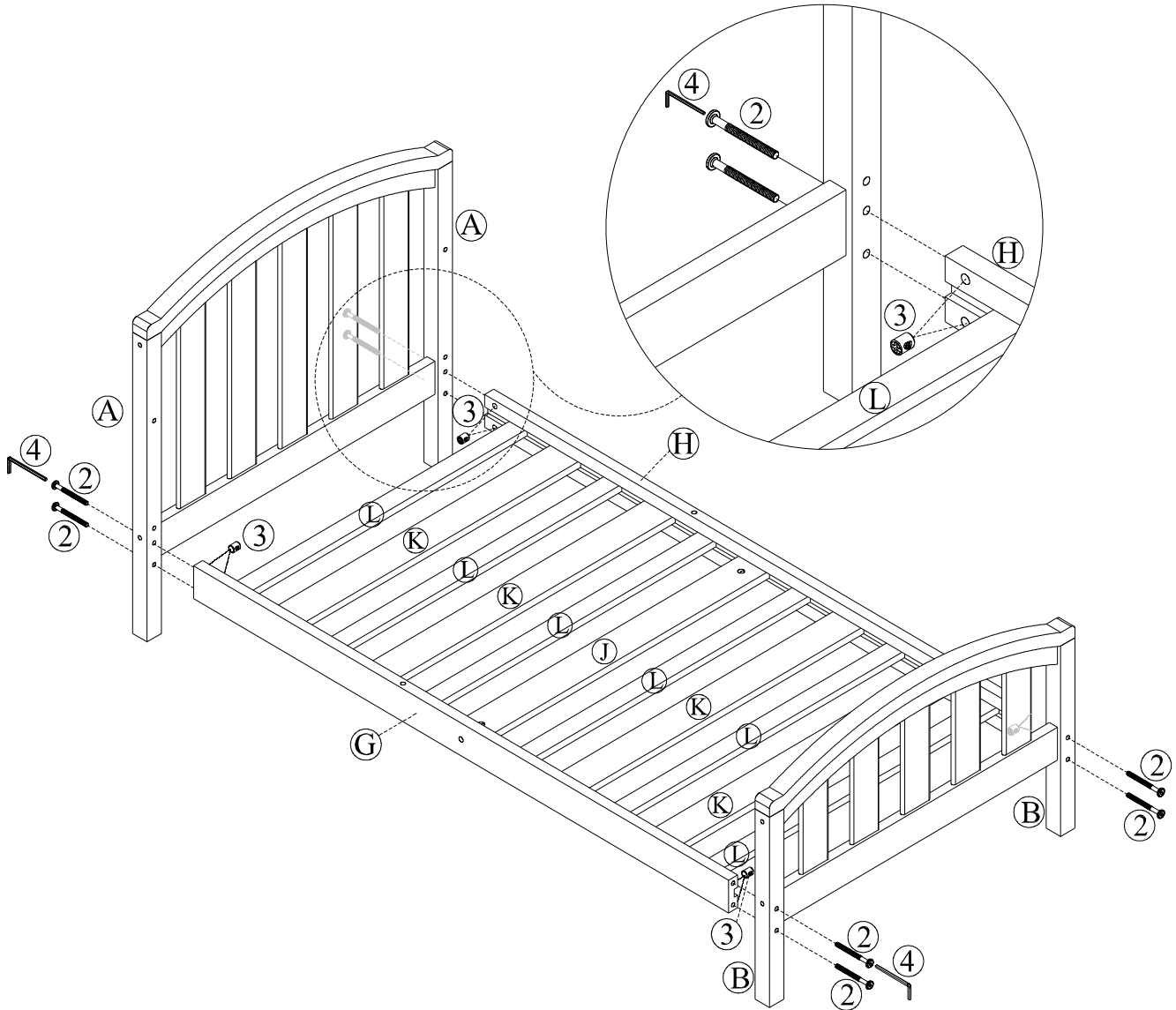

# TODDLER BED

## WM3238C / WM3238E / WM3238W

### STEP 6

Attach the guardrails (I) to the headboard posts (A) with hex socket head bolts (2).  
Attach the guardrails (I) to the left and right side rails (G & H) with hex socket head bolts (1) as shown.

NOTE: Fully tighten all bolts installed in previous steps with Allen Key (4).

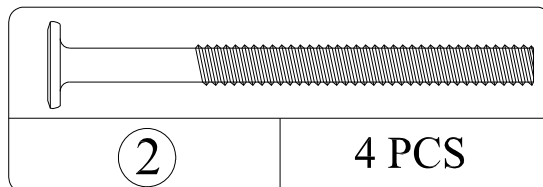
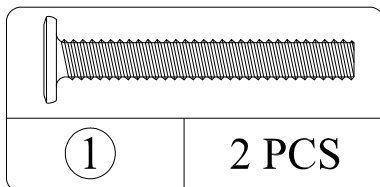
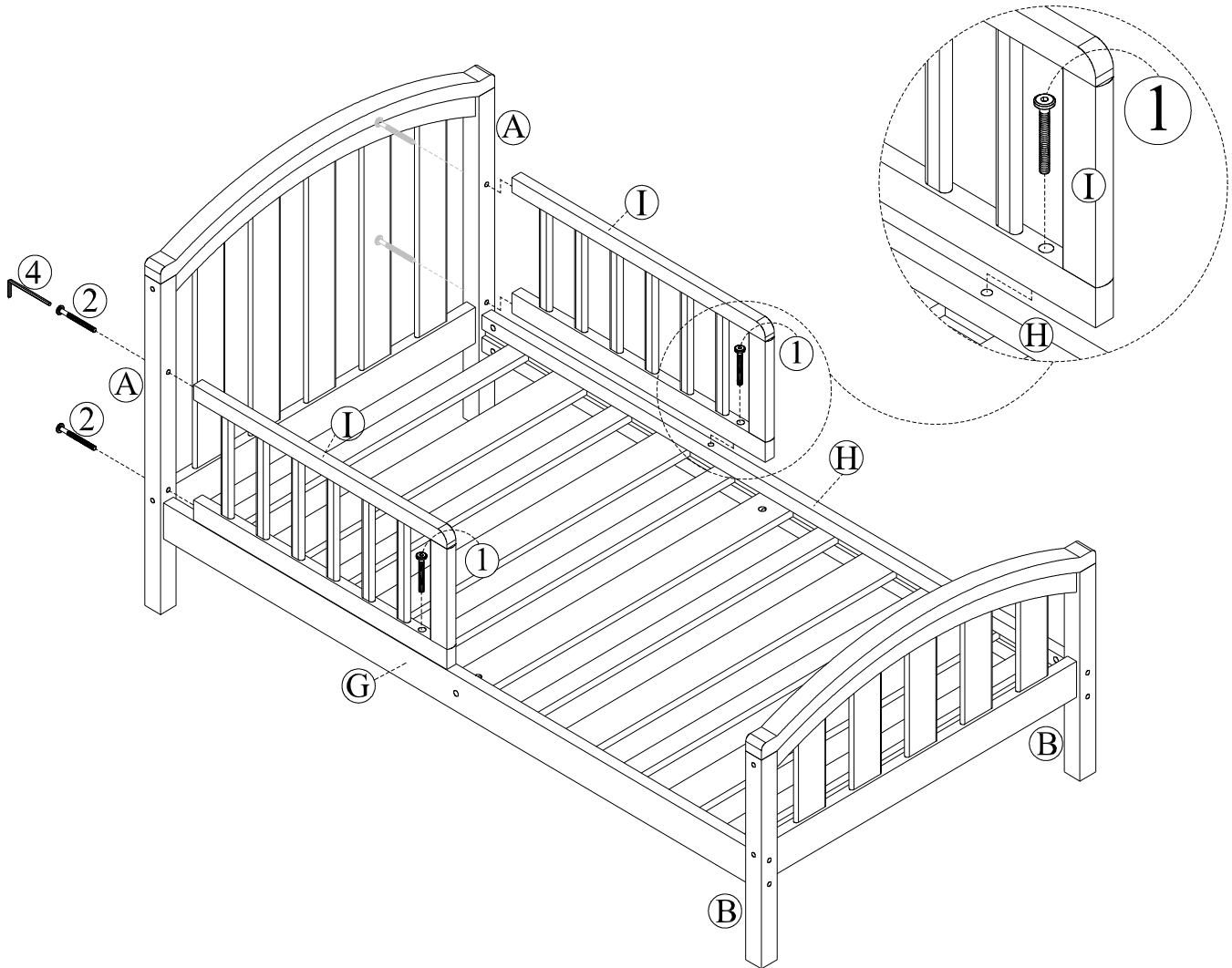

# TODDLER BED

## WM3238C / WM3238E / WM3238W



**CAUTION:** This unit is intended for use only with the products and/or maximum weights indicated. Use with other products and/or products heavier than the maximum weights indicated may result in instability or cause possible injury.

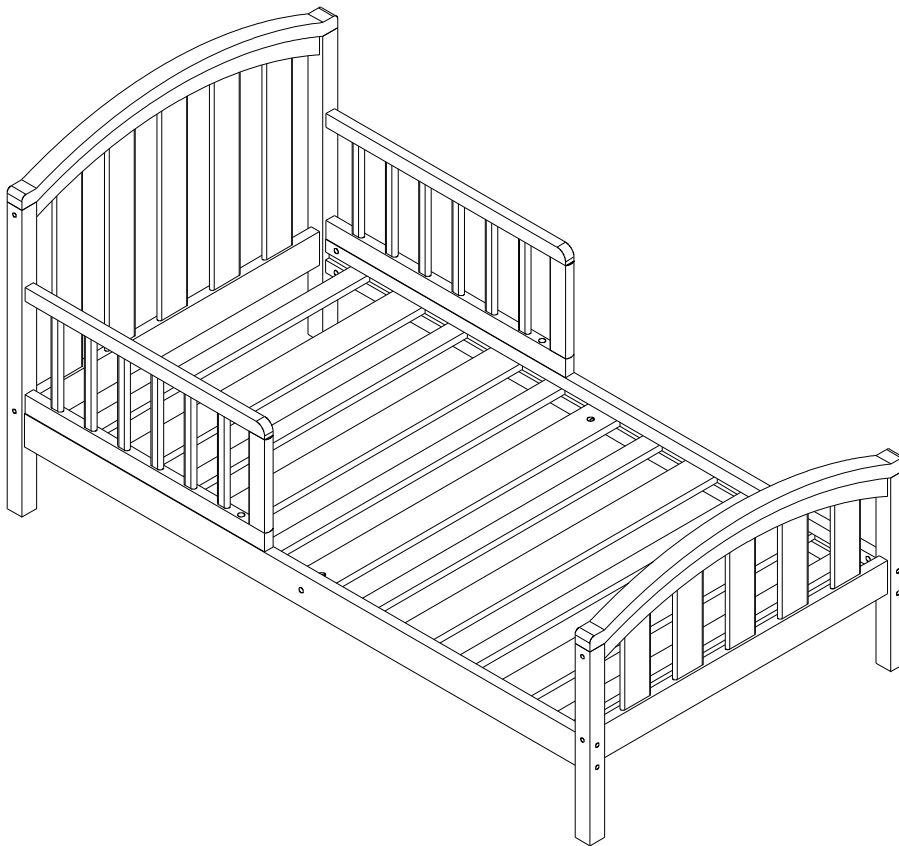

Maximum Weight  
intended = 50 lbs

That's it! You finished assembling your toddler bed.

**DO NOT RETURN PRODUCT TO THE STORE.**

If a part is missing or damaged, Contact our customer service department. We will replace the part FREE of charge.



Tel # : 1-800-295-1980  
E-Mail: [das@dorel.com](mailto:das@dorel.com)  
Fax #: 514-353-7819

# Customer Service

**PLEASE DO NOT RETURN THIS PRODUCT TO THE STORE**

**PLEASE CONTACT CUSTOMER SERVICE REPRESENTATIVES AT THE FOLLOWING NUMBERS SHOULD THERE BE ANY MISSING OR DEFECTIVE PART(S).**

Customer Service Phone Number 1-800-295-1980	Email: <a href="mailto:das@dorel.com">das@dorel.com</a>
Customer Service Fax Number 514-353-7819	

Request Date:

Name:

Shipping Address:

Street & Number:

City & State:

Zip Code:

Day Time Phone Number:

(including area code)

Date & Place of Purchase:

Part(s) description and quantity: (Please be sure to list model number or SKN number)