

88 5901 51

St. Croix

Front Slide-out Desk

IMPORTANT NOTE

Carefully remove all the parts from the carton and put them individually on a soft cloth to prevent scratches or other damages occurring to the wood parts.

We have taken great care in the design of this product and request that you carefully and strictly follow our assembly instructions to ensure a completed product as it was designed.

Home
Styles

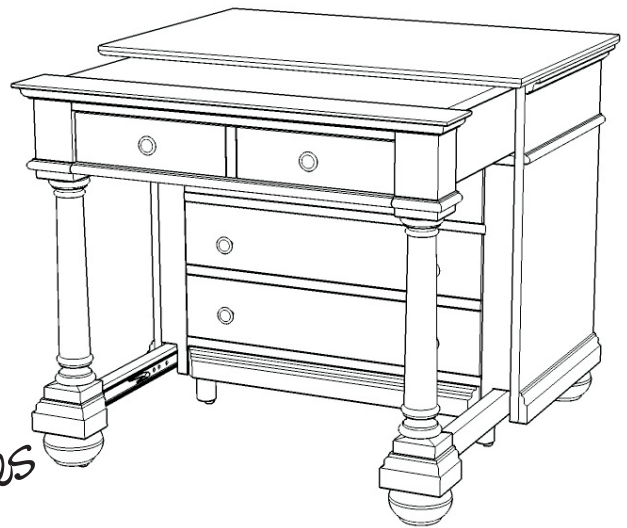

Part List

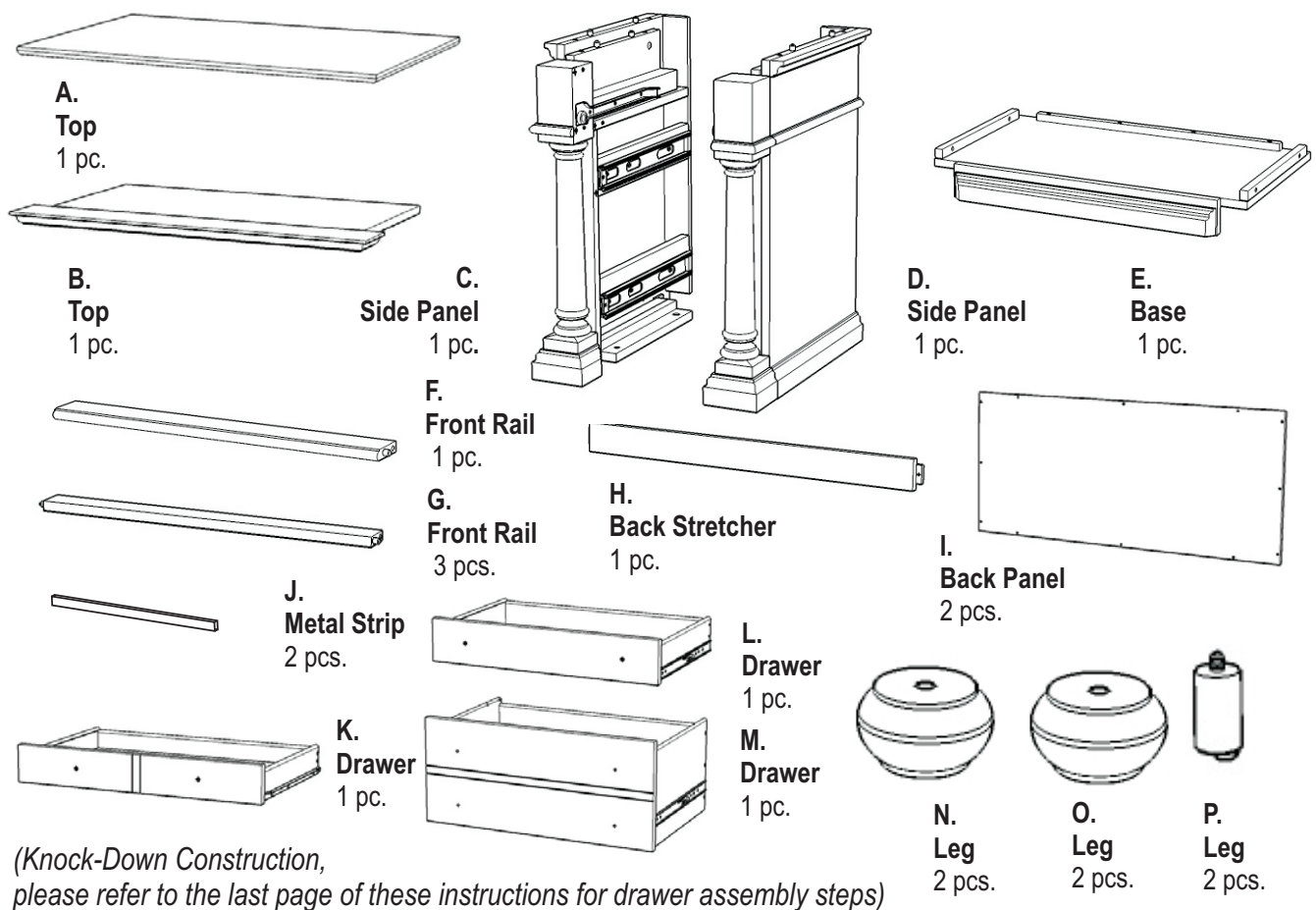

Hardware List



Tools required for assembly : **Phillips** screwdriver

Tools recommended for assembly : Level

Home Styles Consumer Assistance: www.homestyles-furniture.com,
servicedesk@homestyles-furniture.com, 888-680-7460, 877-831-0319

Assembly Instructions 2/7

IMPORTANT

- * Do not tighten up all the screws until each part is properly assembled.
- * You should keep Hex Wrench in a safe place as you may need to tighten up the Head Cap Bolts in the future.
- * Use a soft cloth between these parts and the floor.
- * After assembly, item must be level to work properly. Use the included adjustable levelers to level.

STEP 1

Insert Cam Lock Screws into the pre-drilled holes of Top (A), (B), Side Panel (C) and (D).

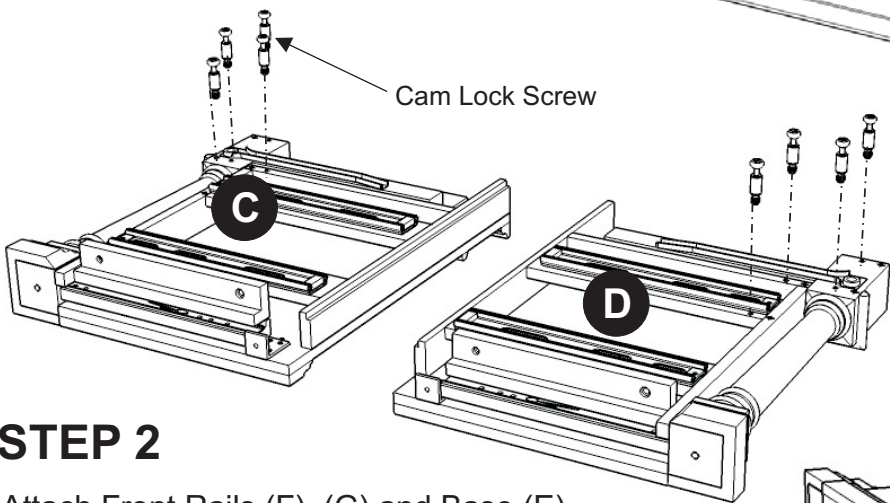

STEP 2

Attach Front Rails (F), (G) and Base (E) to Side Panel (C) with Cam Locks (see Figure 1) and Head Cap Bolts. (See Figure 2)

Attach Side Panel (D) to unit with Cam Locks and Head Cap Bolts.

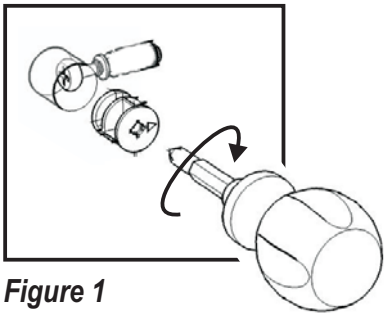

Figure 1

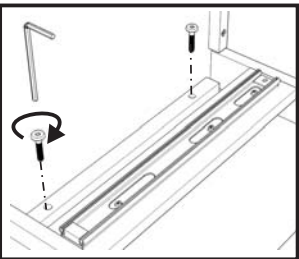
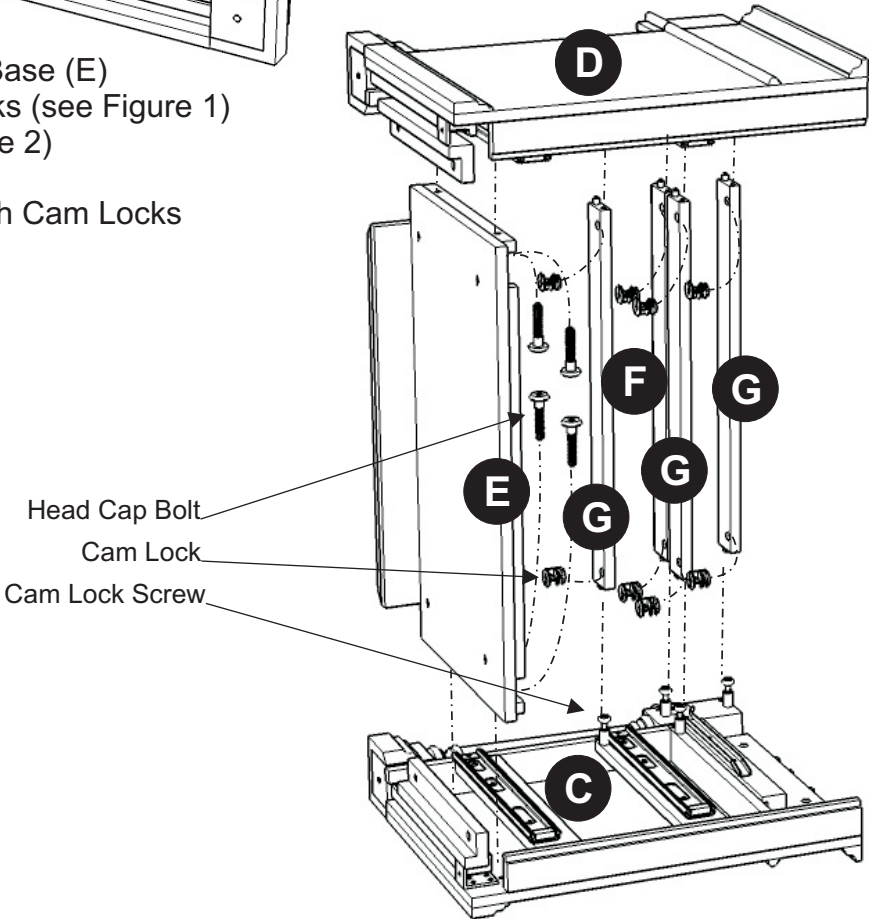
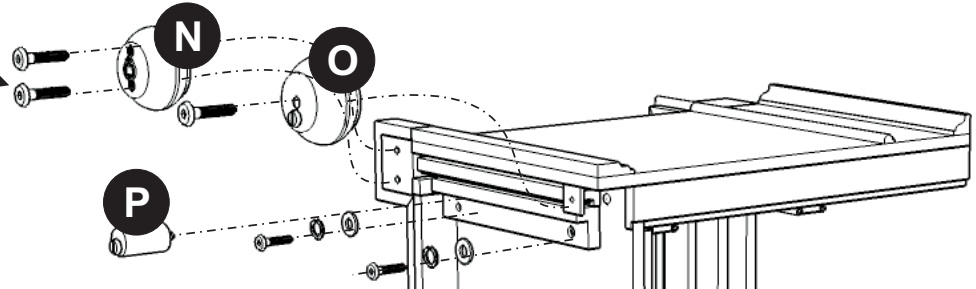

Figure 2



Head Cap Bolt
(large)



STEP 3

Insert Head Cap Bolts, Spring Washers and Flat Washers into the-drilled holes of Base (E).
(See Figure 3)

Attach Legs (N), (O) and (P) to unit with Head Cap Bolts (large).

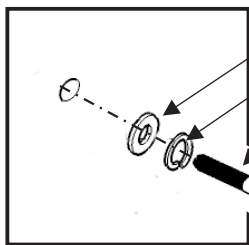
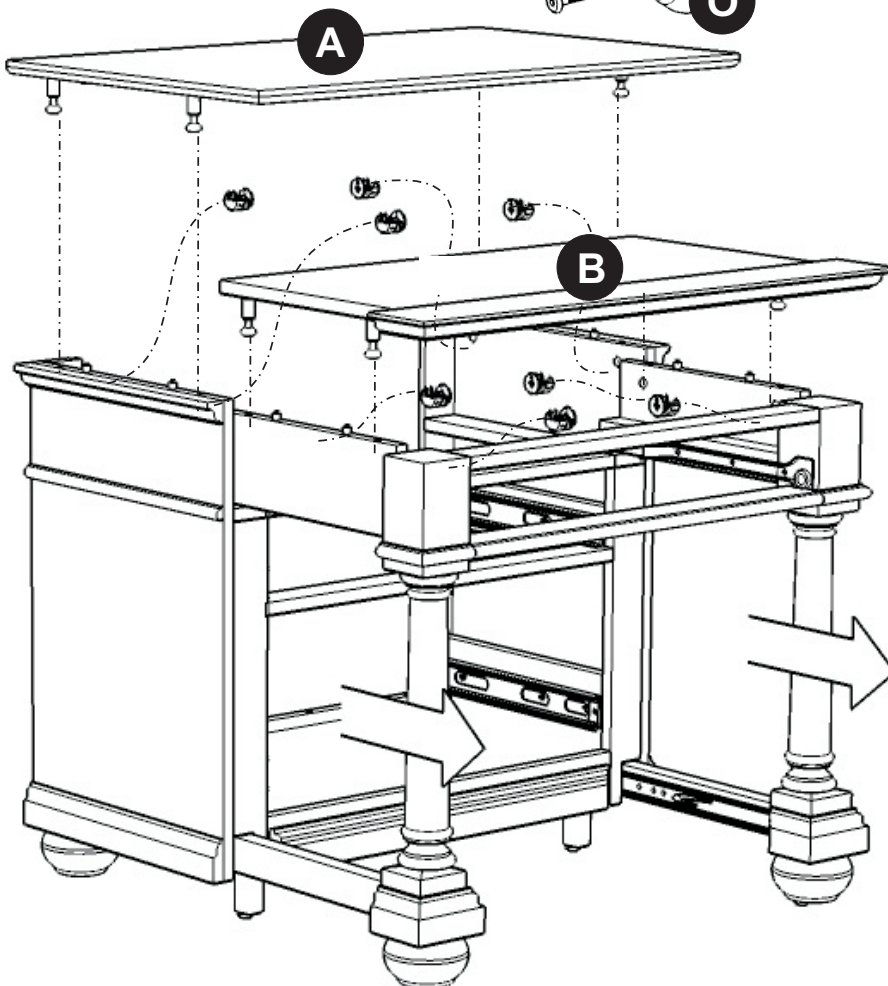

Figure 3

Flat Washer
Spring Washer
Head Cap Bolt



Flat Washer
Spring Washer
Head Cap Bolt



STEP 4

Turn unit to its' up-right position.

Pull out the front legs.

Attach Top (B) to unit with Cam Locks.

Attach Top (A) to unit with Cam Locks.

STEP 5

Slide Drawers (K), (L) and (M) into position.

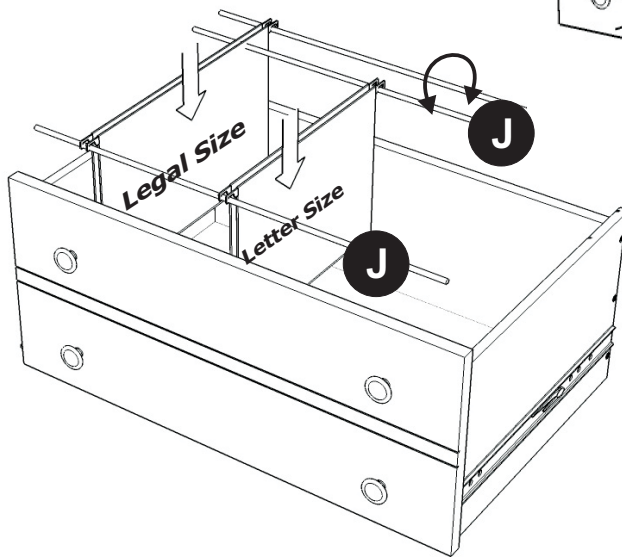
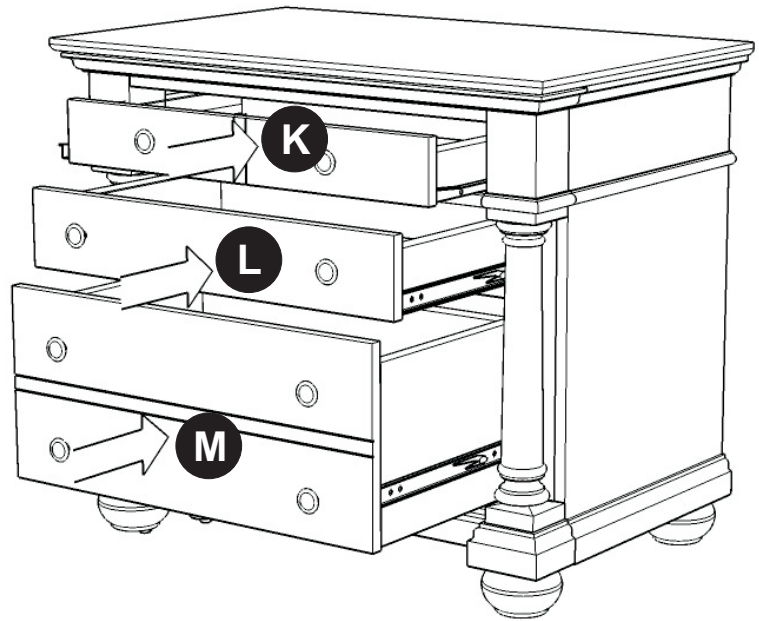

STEP 6

Place Metal Strips (J) into position.

Adjust the Metal Strip for letter size or legal size files as shown.

STEP 7

To level the unit, adjust the adjustable levelers on the bottom of unit. (See Figure 4)

Attach lower Back Panel (I) and Back Stretcher (H) to unit with Wood Screws.

Attach upper Back Panel (I) to unit with Wood Screws.

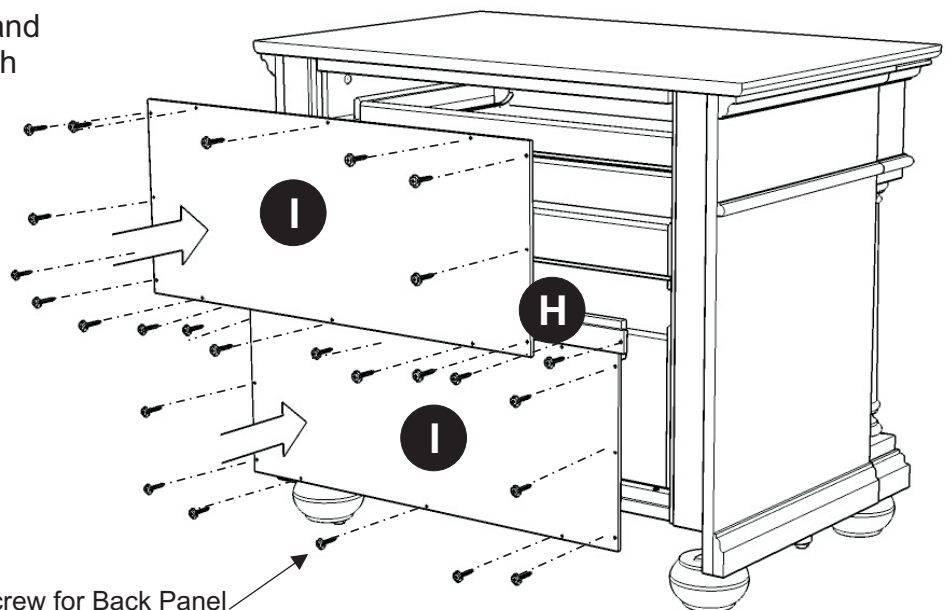

Wood Screw for Back Panel

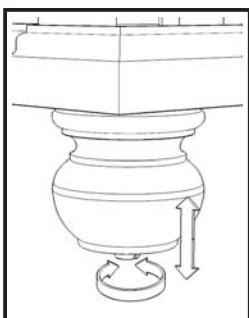

Figure 4

Note: Please make sure unit is level before tightening these screws.

Drawer (K)

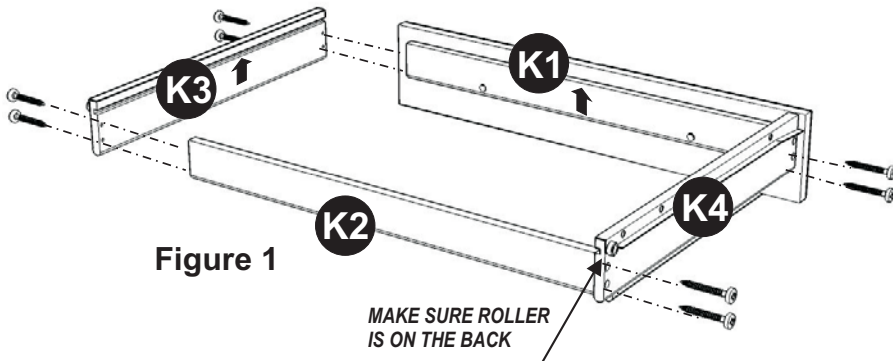
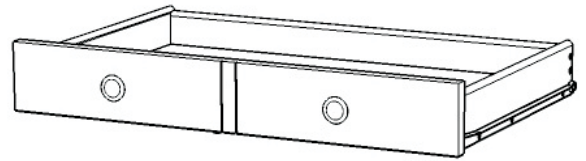

Figure 1

STEP 1

Attach K1 to K3 and K4, using a Phillips screwdriver and long wood screws (4X), tighten halfway.

Attach K2 to K3 and K4 using long wood screws (4X), tighten halfway. (see Figure 1)

STEP 2

Slide K5 into the grooves in K3 and K4. Be sure to push K5 all the way forward so it meets K1. (see Figure 2)

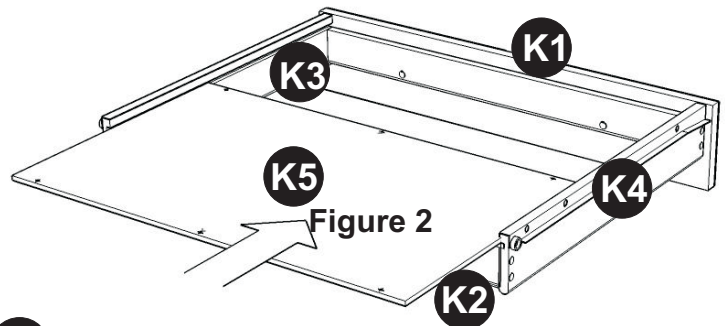

Figure 2

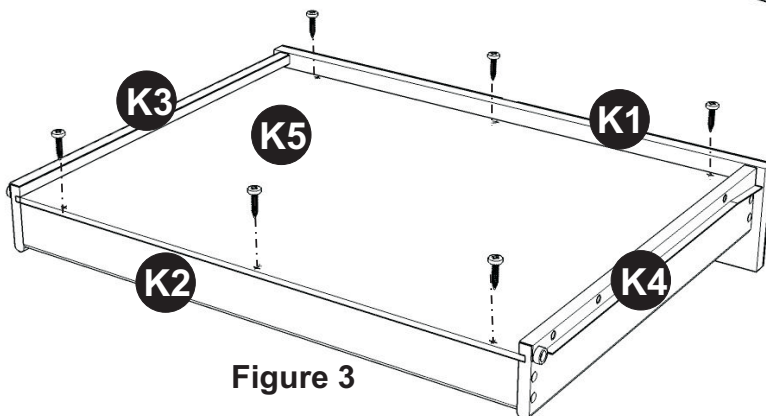

Figure 3

STEP 3

Insert short wood screws (6X) into the pre-drilled holes in K5, tighten screws. (see Figure 3)

STEP 4

Assemble Pull Handle with machine screws. (see Figure 4)

Tighten all screws used in drawer assembly.

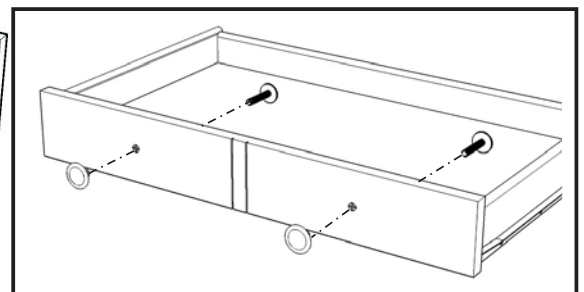
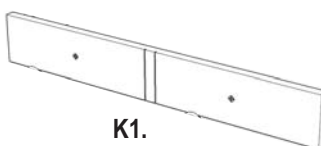

Figure 4

Part List



K1.
Front Part
1 pc.



K2.
Back Part
1 pc.

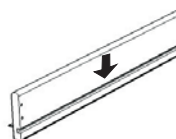

K3.
Side Part
1 pc.

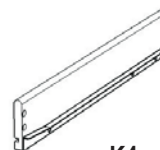

K4.
Side Part
1 pc.



K5.
Base Part
1 pc.

Drawer (L)

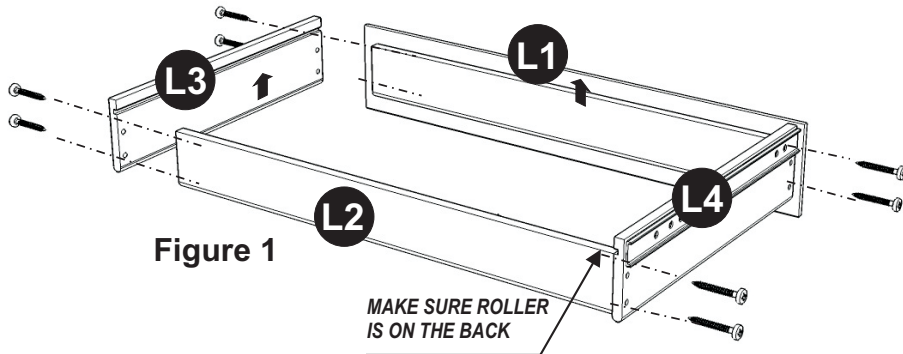
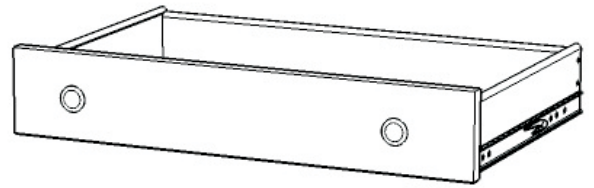

Figure 1

STEP 1

Attach L1 to L3 and L4, using a Phillips screwdriver and long wood screws (4X), tighten halfway.

Attach L2 to L3 and L4 using long wood screws (4X), tighten halfway. (see Figure 1)

STEP 2

Slide L5 into the grooves in L3 and L4. Be sure to push L5 all the way forward so it meets L1. (see Figure 2)

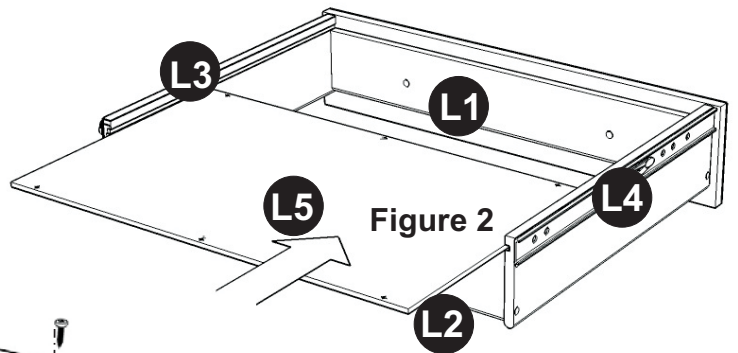

Figure 2

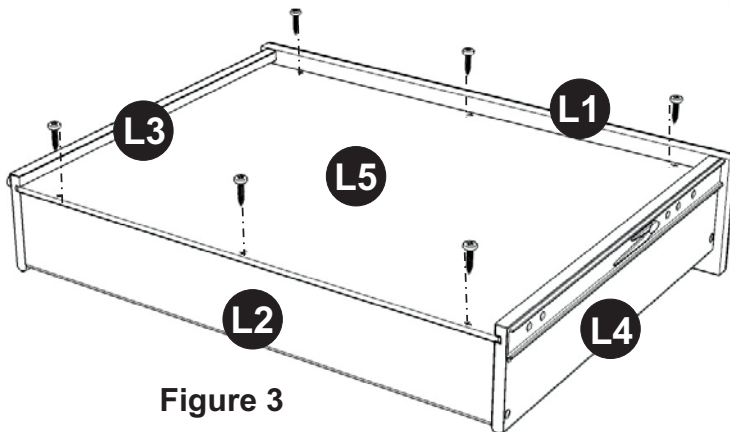

Figure 3

STEP 3

Insert short wood screws (6X) into the pre-drilled holes in L5, tighten screws. (see Figure 3)

STEP 4

Assemble Pull Handle with machine screws. (see Figure 4)

Tighten all screws used in drawer assembly.

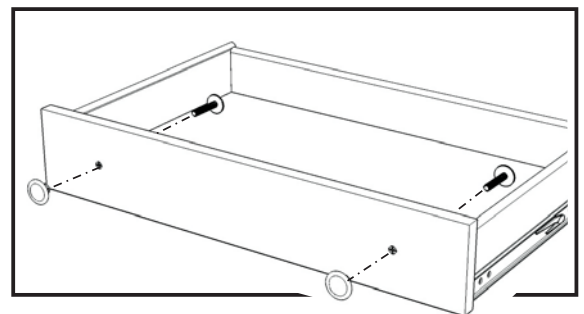
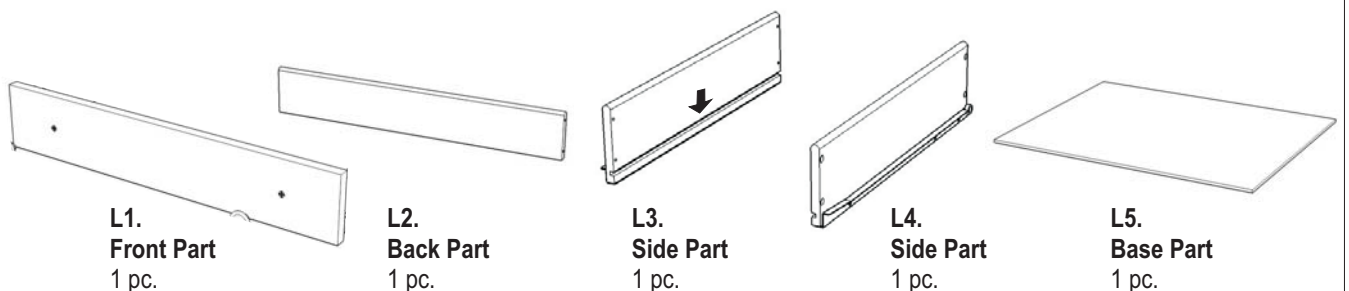

Figure 4

Part List



Drawer (M)

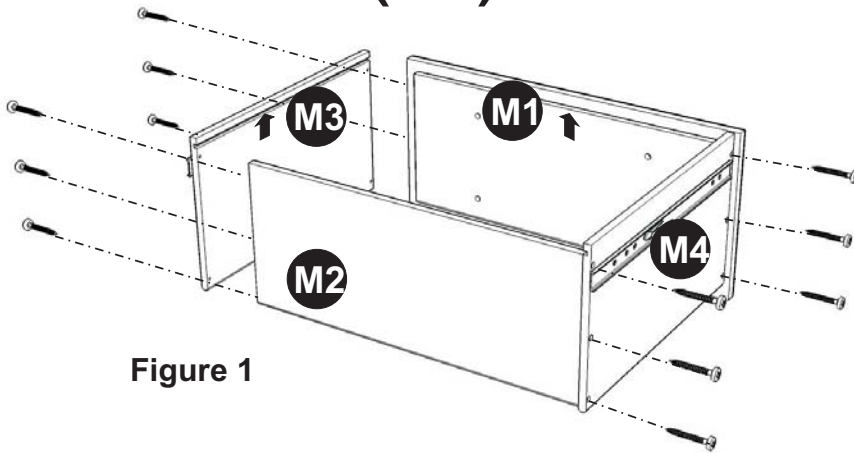
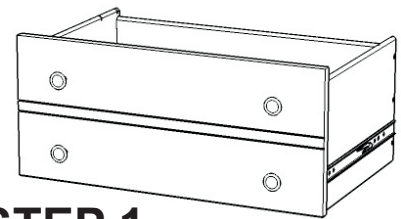

Figure 1



STEP 1

Attach M1 to M3 and M4 using a Phillips screwdriver and long wood screws (6X), tighten halfway.

Attach M2 to M3 and M4 using long wood screws (6X), tighten halfway. (see Figure 1)

STEP 2

Slide M5 into the grooves in M3 and M4. Be sure to push M5 all the way forward so it meets M1. (see Figure 2)

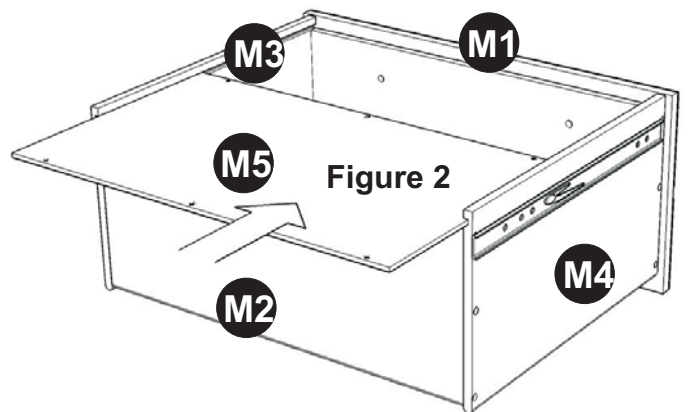

Figure 2

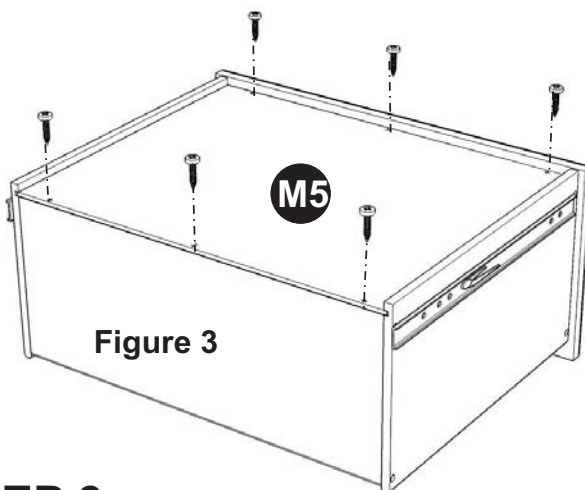

Figure 3

STEP 3

Insert short wood screws (6X) into the pre-drilled holes in M5, tighten screws. (see Figure 3)

STEP 4

Assemble Pull Handle with machine screws. (see Figure 4)

Tighten all screws used in drawer assembly.

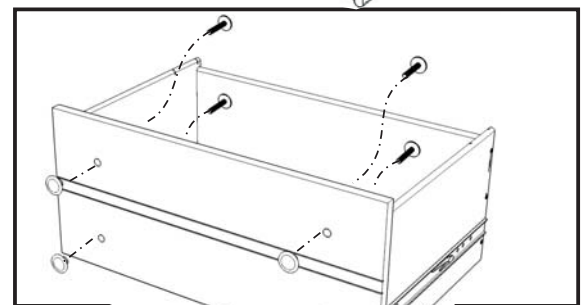
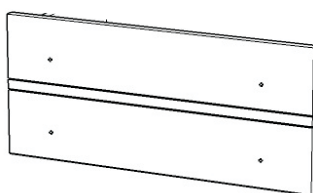
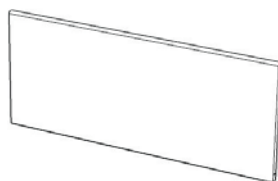

Figure 4

Part List



M1.
Front Part
1 pc.



M2.
Back Part
1 pc.

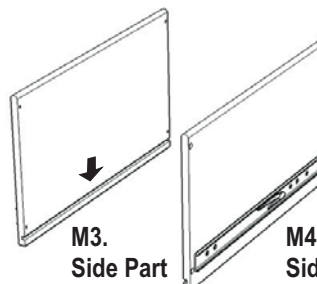

M3.
Side Part
1 pc.

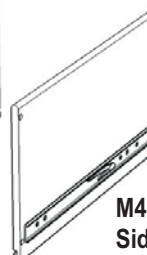

M4.
Side Part
1 pc.



M5.
Base Part
1 pc.