

# 88 5194 94

## Marco Islands Kitchen Island

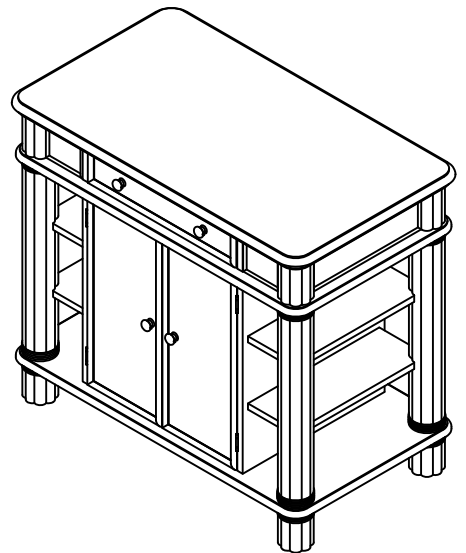

Home  
Styles

### IMPORTANT NOTE

Carefully remove all the parts from the carton and put them individually on a soft cloth to prevent scratches or other damages occurring to the parts.

We have taken great care in the design of this product and request that you carefully and strictly follow our assembly instructions to ensure a completed product as it was designed.

## Part List

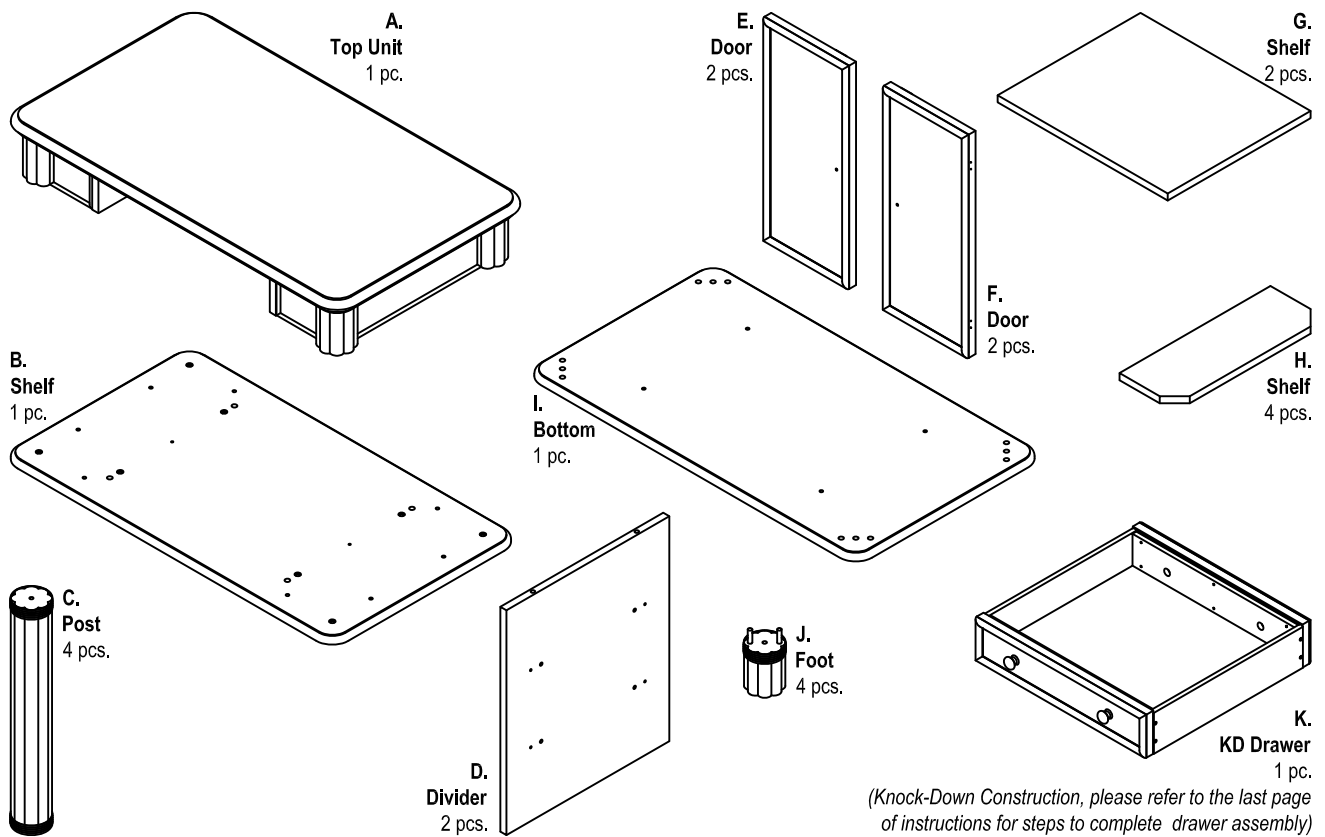

## Hardware List

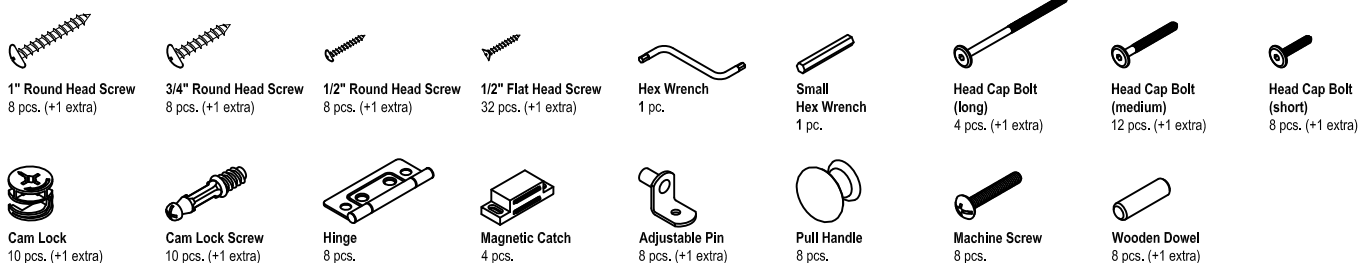

Tools Required For Assembly : Phillips screwdriver

Tools Recommended For Assembly : Level

Home Styles Consumer Assistance Line 888-680-7460 and 877-831-0319  
servicedesk@homestyles-furniture.com

# Assembly Instructions 2/8

## IMPORTANT

- \* Please keep Hex Wrench in a safe place as you may need to tighten up the Head Cap Bolts in the future.
- \* Do not tighten up all the screws until each part is properly assembled.
- \* Use a soft cloth between these parts and the floor.
- \* After assembly, item must be level to work properly. Use the included adjustable levelers to level.

## STEP 1

Insert Cam Lock Screws into the pre-drilled holes of Dividers (D).

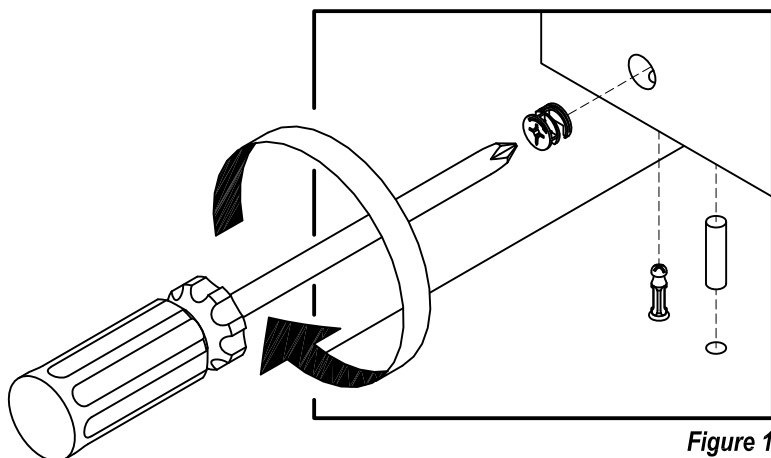
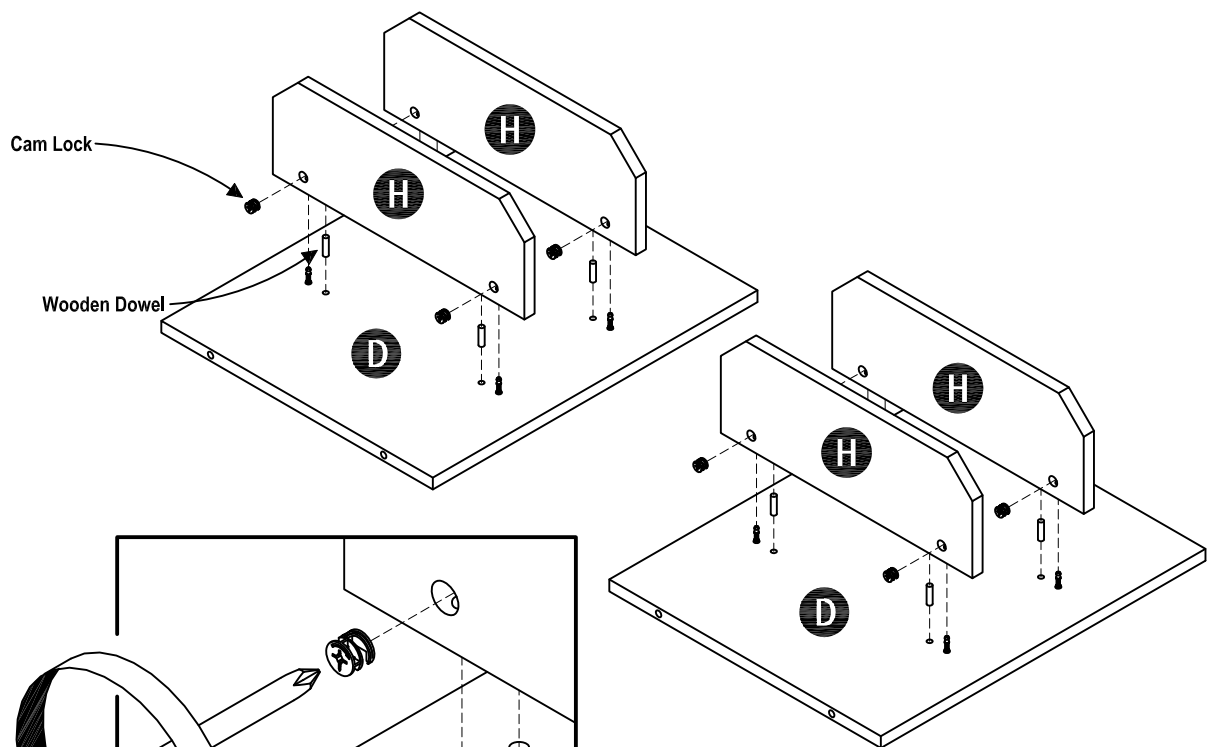
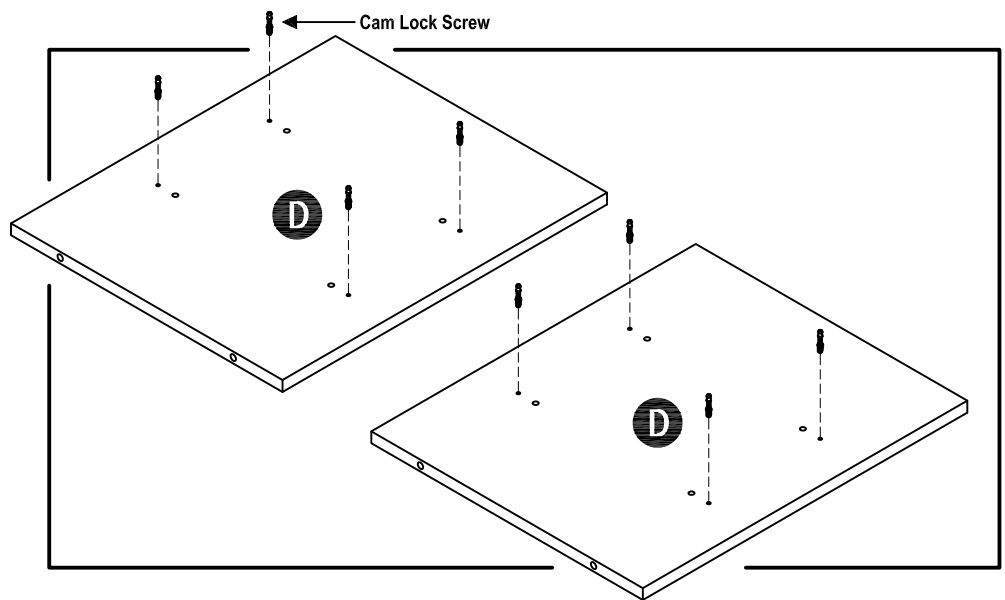

## STEP 2

Attach Shelves (H) to Dividers (D) using Cam Locks and Wooden Dowels. (See figure 1)

# Assembly Instructions 3/8

## STEP 3

Attach Posts (C) and Feet (J) to Bottom (I) using Head Cap Bolts (long).

Tighten Bolts using Hex Wrench. (See figure 2)

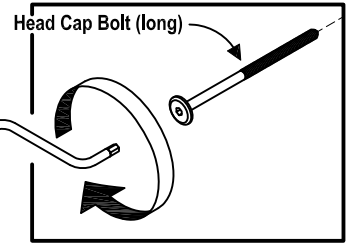
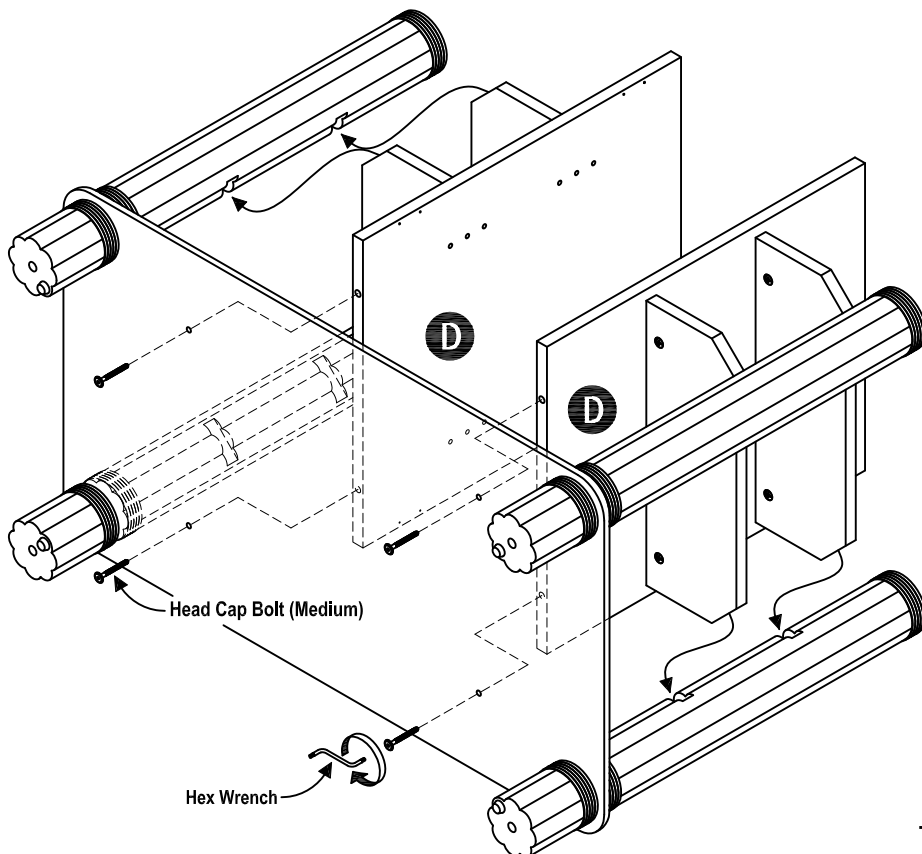
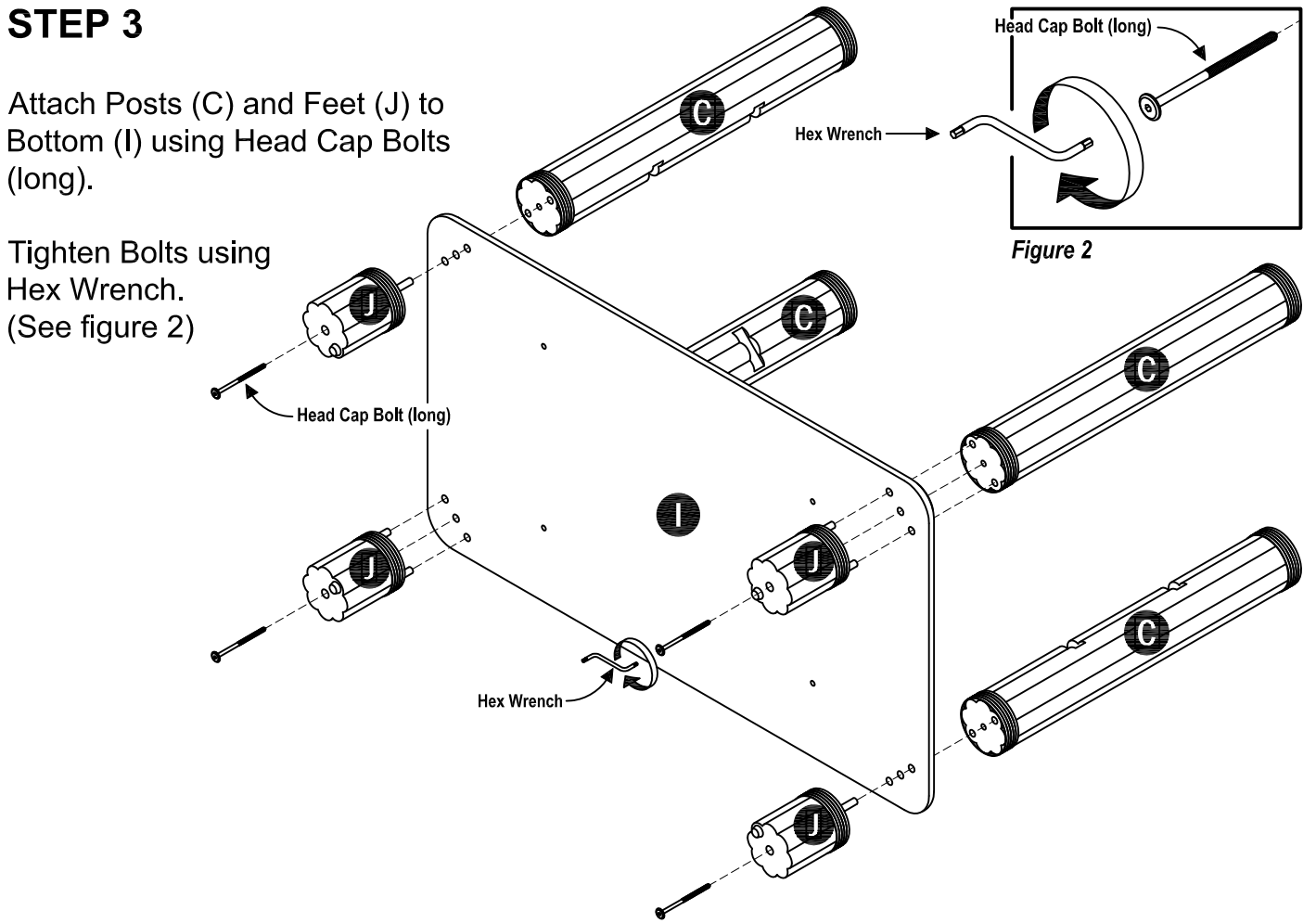

Figure 2



## STEP 4

Attach Dividers (D) to unit using Head Cap Bolts (Medium).

Tighten Bolts using Hex Wrench.

# Assembly Instructions 4/8

## STEP 5

Attach Magnetic Catches to Shelf (B) using 3/4" Round Head Screw.

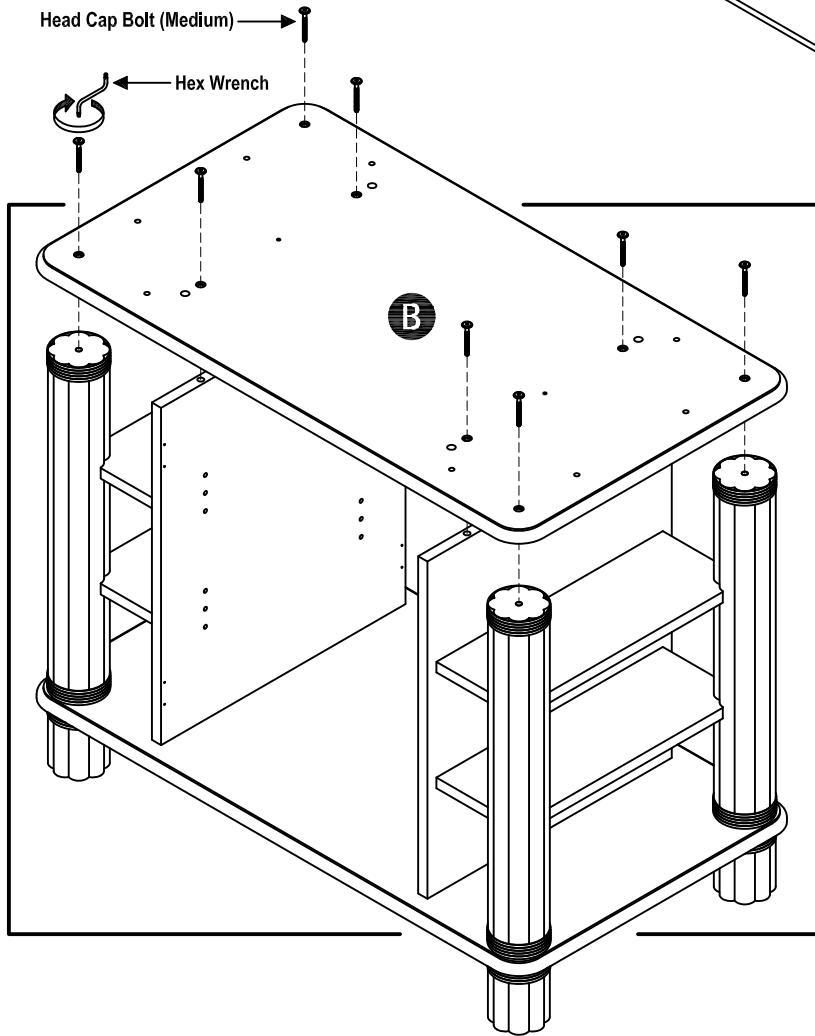
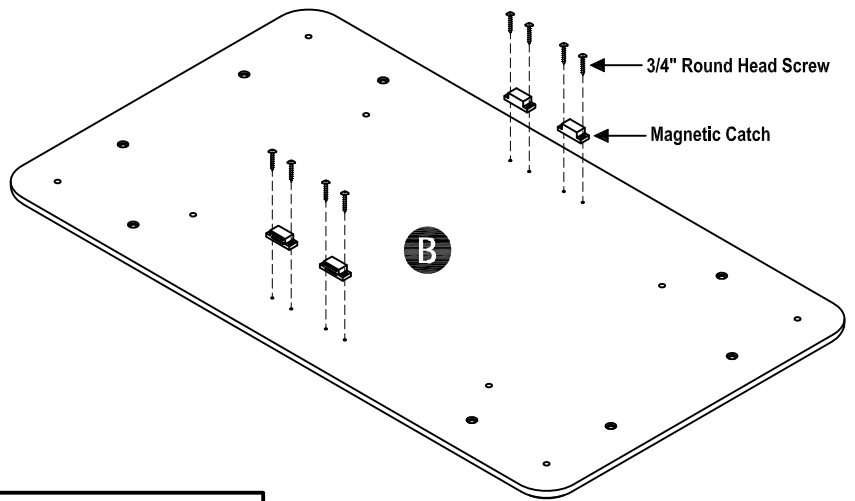

## STEP 6

Attach Shelf (B) unit using Head Cap Bolts (medium).

Tighten bolts using Hex Wrench.

## STEP 7

Insert Cam Lock Screws into the pre-drilled holes of unit.

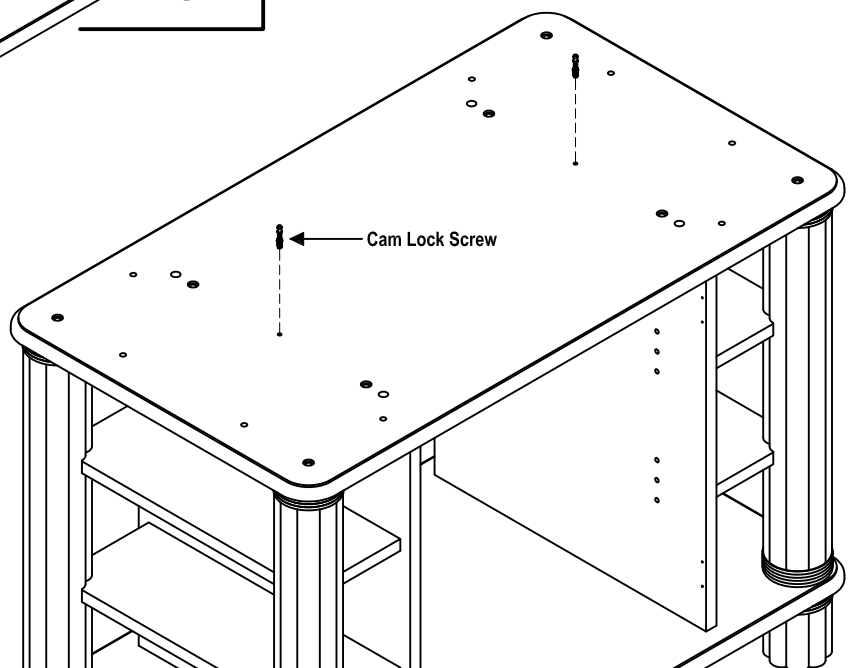

# Assembly Instructions 5/8

## STEP 8

Insert Cam Locks into Top Unit (A)

**Note: The arrow mark of Cam Locks must point down.**

(See figure 3)

Place Top Unit (A) onto unit.

Tighten the Cam Locks.

Attach Head Cap Bolts (short) to unit. Tighten using Hex Wrench.

(See figure 4)

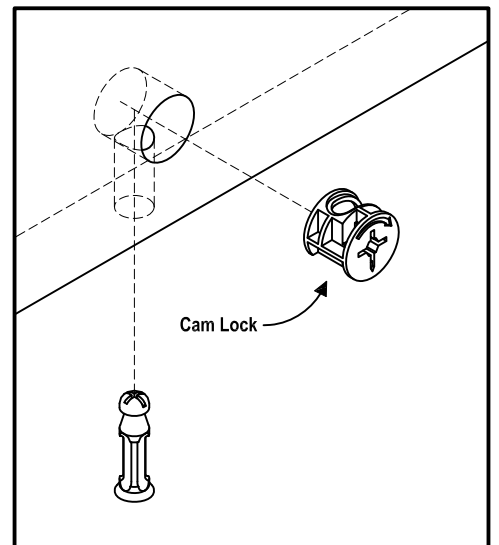
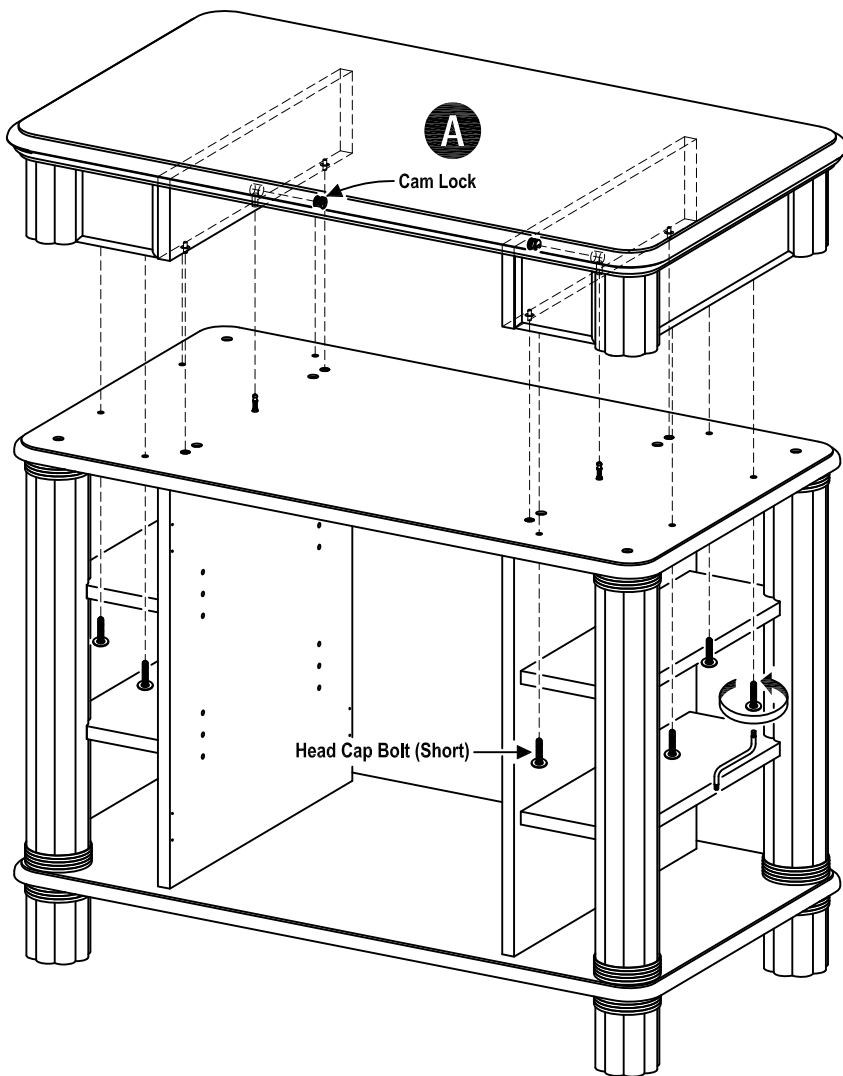

Figure 3

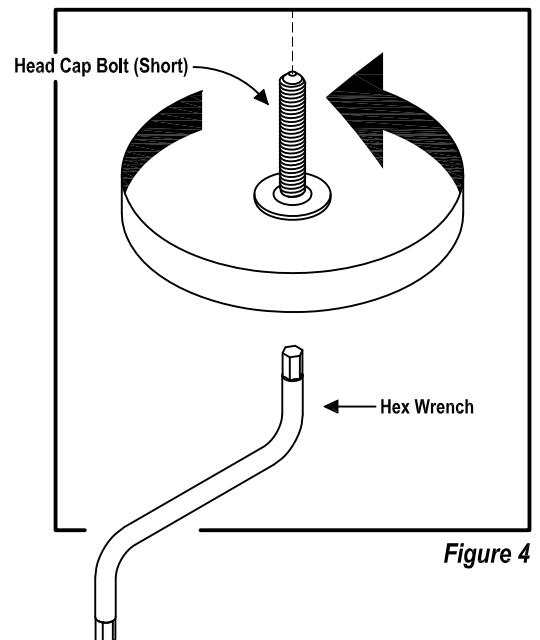
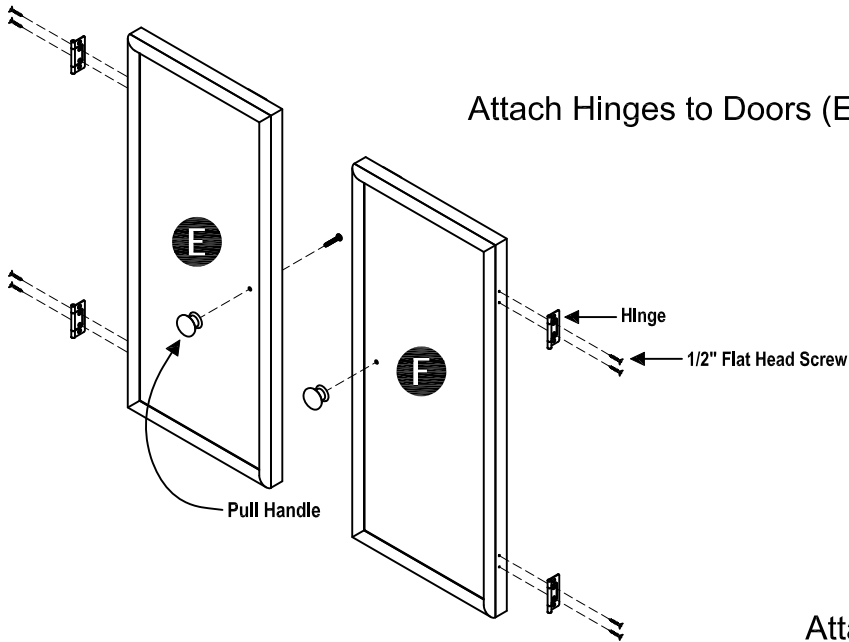

Figure 4

# Assembly Instructions 6/8

## STEP 9



Attach Hinges to Doors (E) and (F) using 1/2" Flat Head Screw.  
(See figure 5)

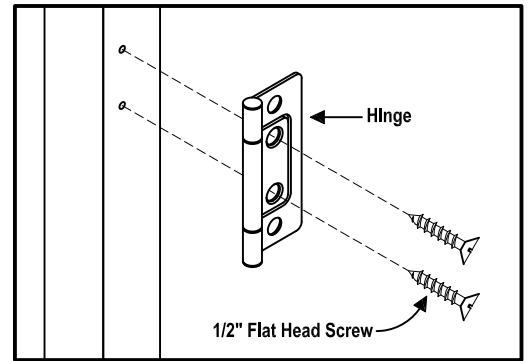
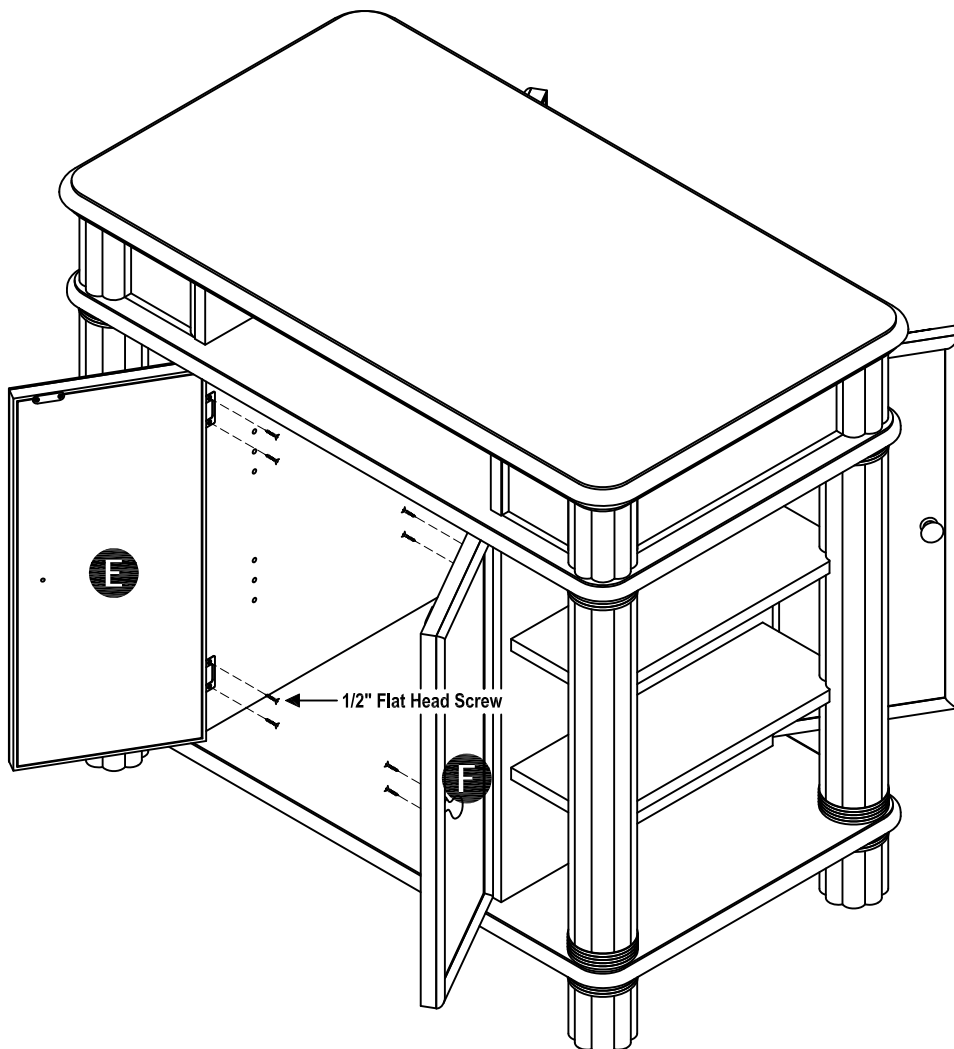

Figure 5

Attach Pull Handles to Doors (E) and (F)  
with Machine Screws.



## STEP 10

Attach Doors (E) and (F) to  
unit using 1/2" Flat Head  
Screw.  
(See figure 6)

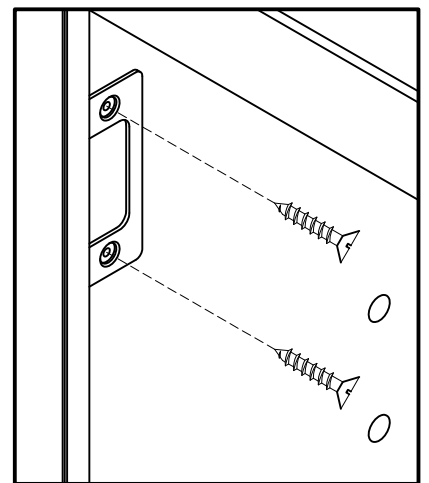

Figure 6

# Assembly Instructions 7/8

## STEP 11

Insert Adjustable Pins at the desired level.

Place Shelf (G) onto Adjustable Pins.

Attach 1/2" Round Head Screws through Adjustable Pins to Shelf (G).  
(see Figure 7)

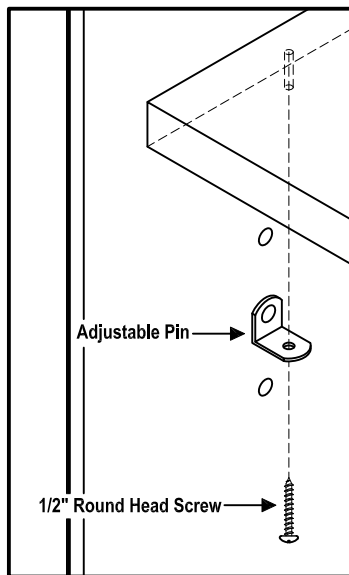
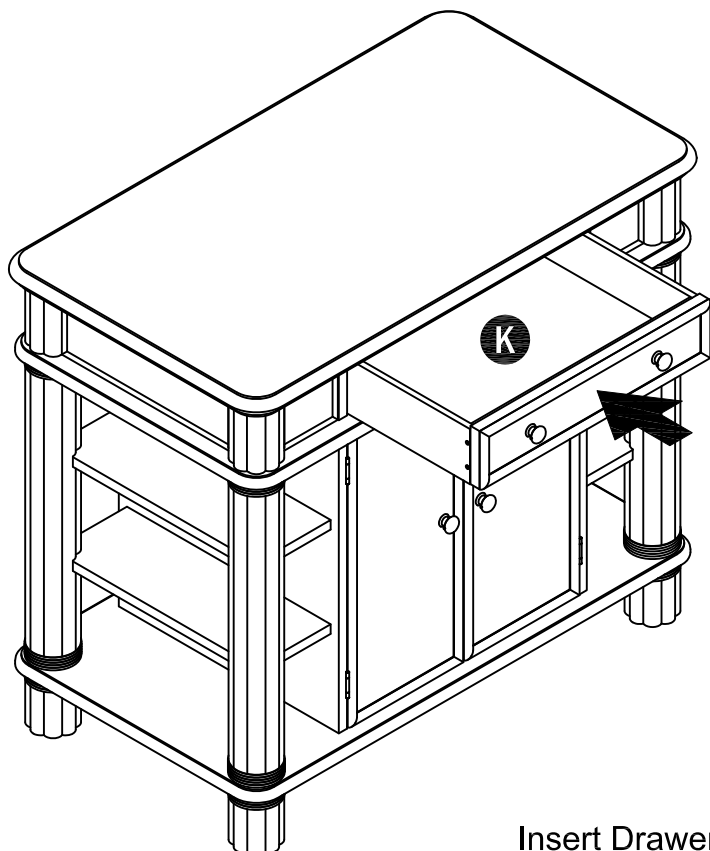
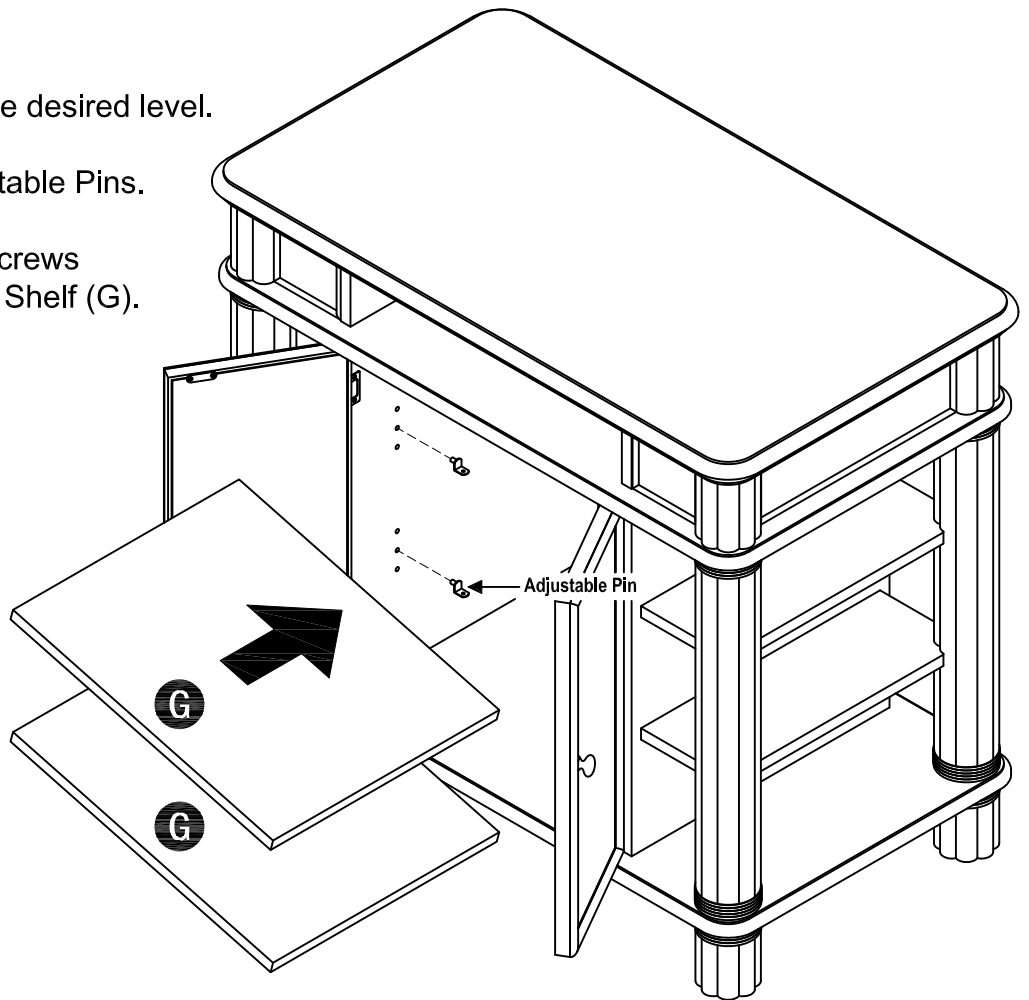

Figure 7



Insert Drawer (K) into unit.

## STEP 13

To level the unit, adjust the adjustable levelers on the bottom.

**Note: Unit must be level to work properly.**

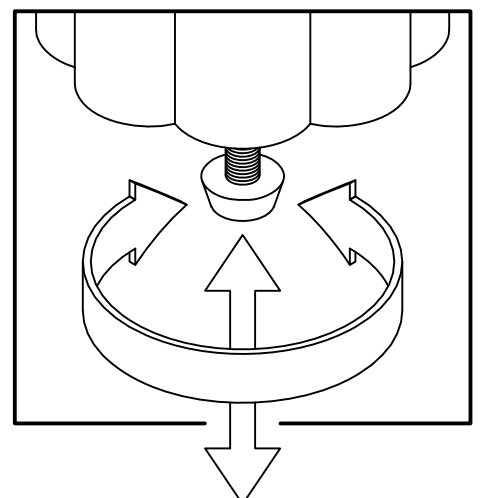

## STEP 12

## Drawer (K)

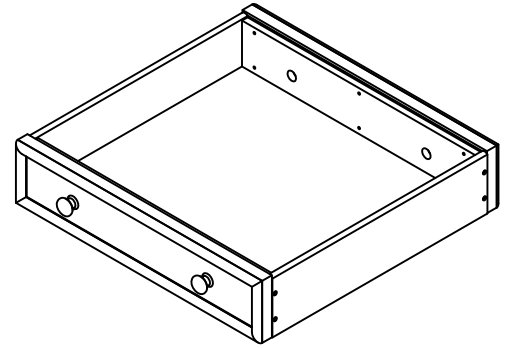

### STEP 1

Attach Base Part (K4) to Front Parts (K1)

Attach Side Part (K2) to Front Parts (K1) using a Phillips screwdriver and 1" Round Head Screws.

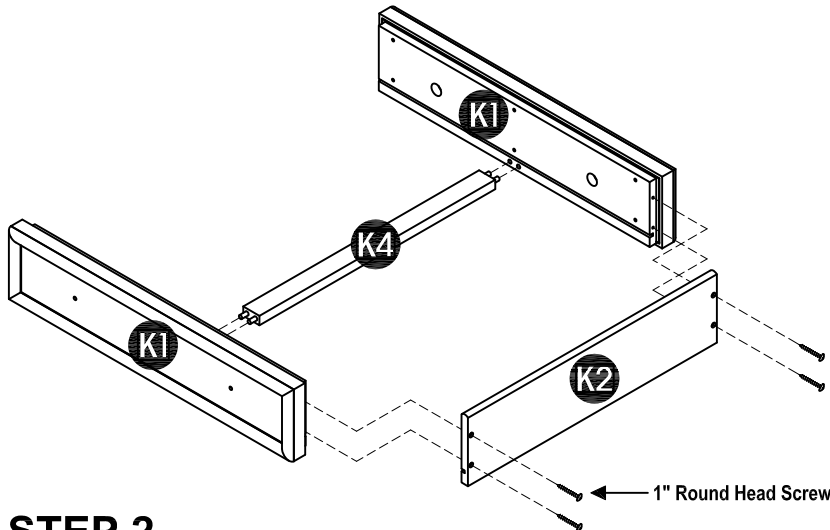

### STEP 2

Insert Base Part (K3) into the groove.

Attach Side Part (K2) to Front Parts (K1) using a Phillips screwdriver and 1" Round Head Screws.

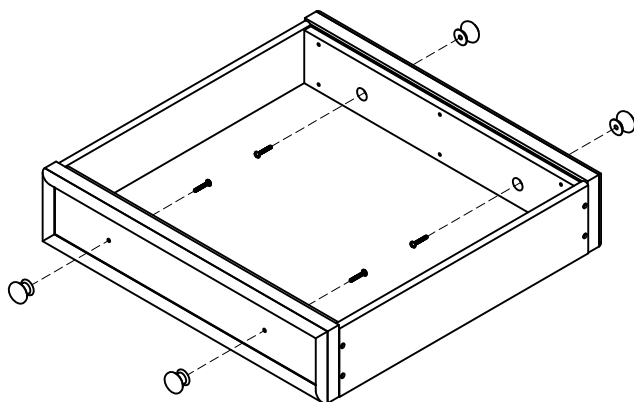
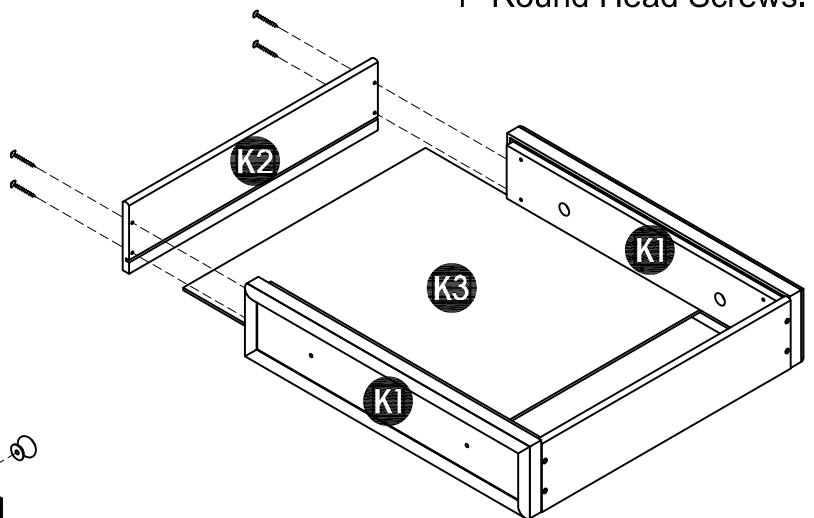

### STEP 3

Attach Pull Handles with Machine Screws.

## Part List

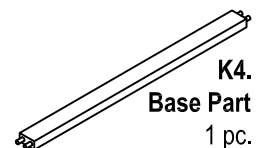
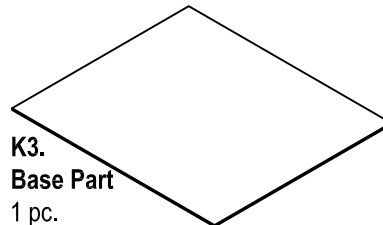
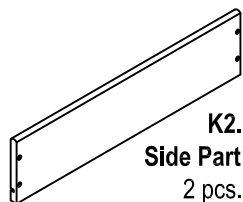
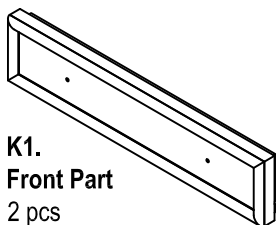



# VERY IMPORTANT !!

## CARE INSTRUCTIONS

### NEVER

USE GLASS CLEANERS ON FINISHED FURNITURE. AMMONIA WILL CHEMICALLY ATTACK THE LACQUER.

### NEVER

ALLOW LIQUIDS OF ANY KIND TO REMAIN ON THE FURNITURE. ABSORPTION CAUSES WOOD TO WARP AND SPLIT AND FINISHES TO DELAMINATE.

DO NOT WRITE DIRECTLY ON SURFACE.



**PREVENT MARKING**

DO NOT PLACE IN DIRECT SUNLIGHT.



**PREVENT FADING**

DO NOT USE COMMERCIAL WAXES AND POLISHES.

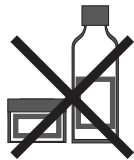

**PREVENT YELLOWING**

DO NOT PLACE HOT OBJECTS ON SURFACE.



**PREVENT FINISH DAMAGE**

DO NOT USE RUBBER BASED PLACE MATS.



**PREVENT DISCOLORING**

## TO CLEAN

USE A SOFT CLOTH MOISTENED IN LEMON OIL POLISH OR LUKEWARM SOAP AND WATER, THEN BUFF WITH A DRY CLEAN CLOTH.

