

88 5902 361

Rio Vista Game Table

IMPORTANT NOTE

Carefully remove all the parts from the carton and put them individually on a soft cloth to prevent scratches or other damages occurring to the wood parts.

We have taken great care in the design of this product and request that you carefully and strictly follow our assembly instructions to ensure a completed product as it was designed.

*Home
Styles*

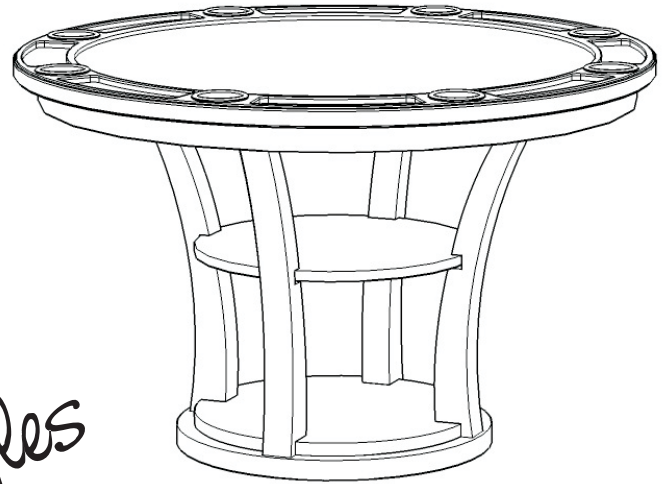

Part List

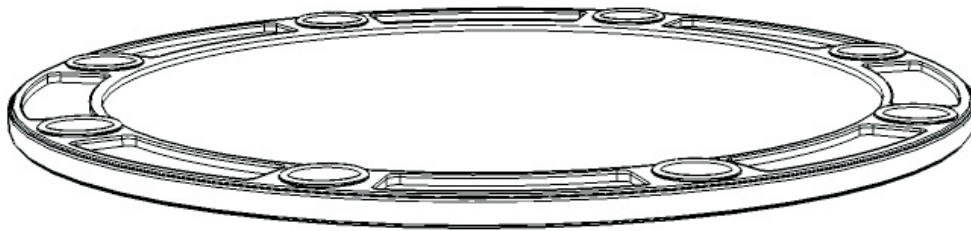

A.
Table Top
1 pc.

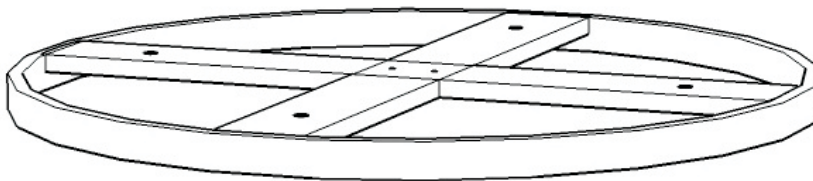

B.
Top Support
1 pc.

For assembly see instructions in carton 88 5902 362

Tools recommended for assembly : Level

Home Styles Consumer Assistance: www.homestyles-furniture.com,
servicedesk@homestyles-furniture.com, 888-680-7460, 877-831-0319

88 5902 362

Rio Vista Game Table

IMPORTANT NOTE

Carefully remove all the parts from the carton and put them individually on a soft cloth to prevent scratches or other damages occurring to the wood parts.

We have taken great care in the design of this product and request that you carefully and strictly follow our assembly instructions to ensure a completed product as it was designed.

*Home
Styles*

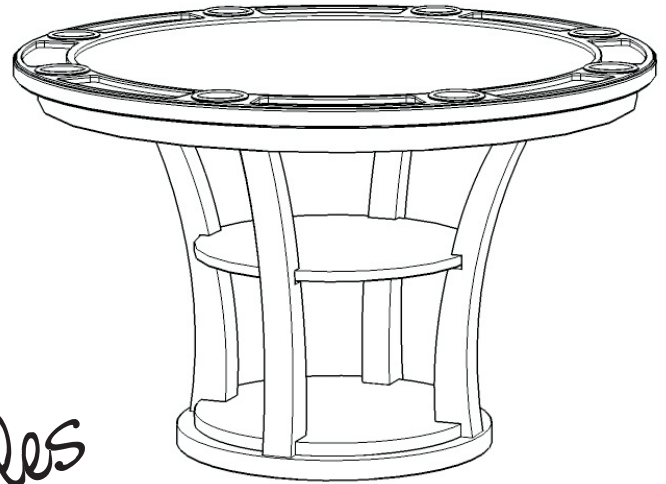

Part List

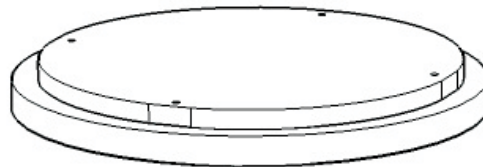
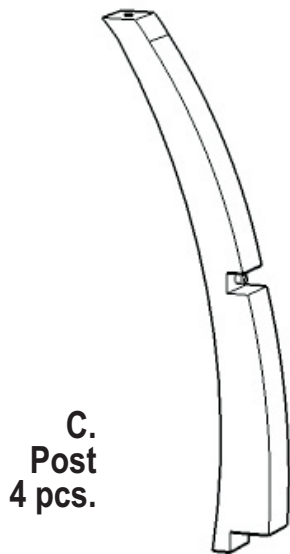

**D.
Base
1 pc.**



**E.
Shelf
1 pc.**

Hardware List



**Flat
Washer
8 pcs. (+ 1 extra)**

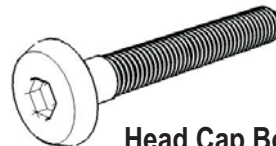

**Head Cap Bolt (long)
4 pcs. (+1 extra)**



**Spring
Washer
8 pcs. (+1 extra)**

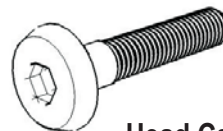

**Head Cap Bolt (short)
4 pcs. (+1 extra)**



**Spacer
4 pcs. (+1 extra)**

Also need the Parts from carton 88 5902 361

Tools recommended for assembly : Level

Home Styles Consumer Assistance: www.homestyles-furniture.com,
servicedesk@homestyles-furniture.com, 888-680-7460, 877-831-0319

Assembly Instructions

IMPORTANT

- * Do not tighten up all the screws until each part is properly assembled.
- * You should keep Hex Wrench in a safe place as you may need to tighten up the Head Cap Bolts in the future.
- * After assembly, item must be level to work properly. Use the included adjustable levelers to level.

STEP 1

Attach Leg (C) to Base (D), using Flat Washer, Spring Washer and Head Cap Bolt (long).

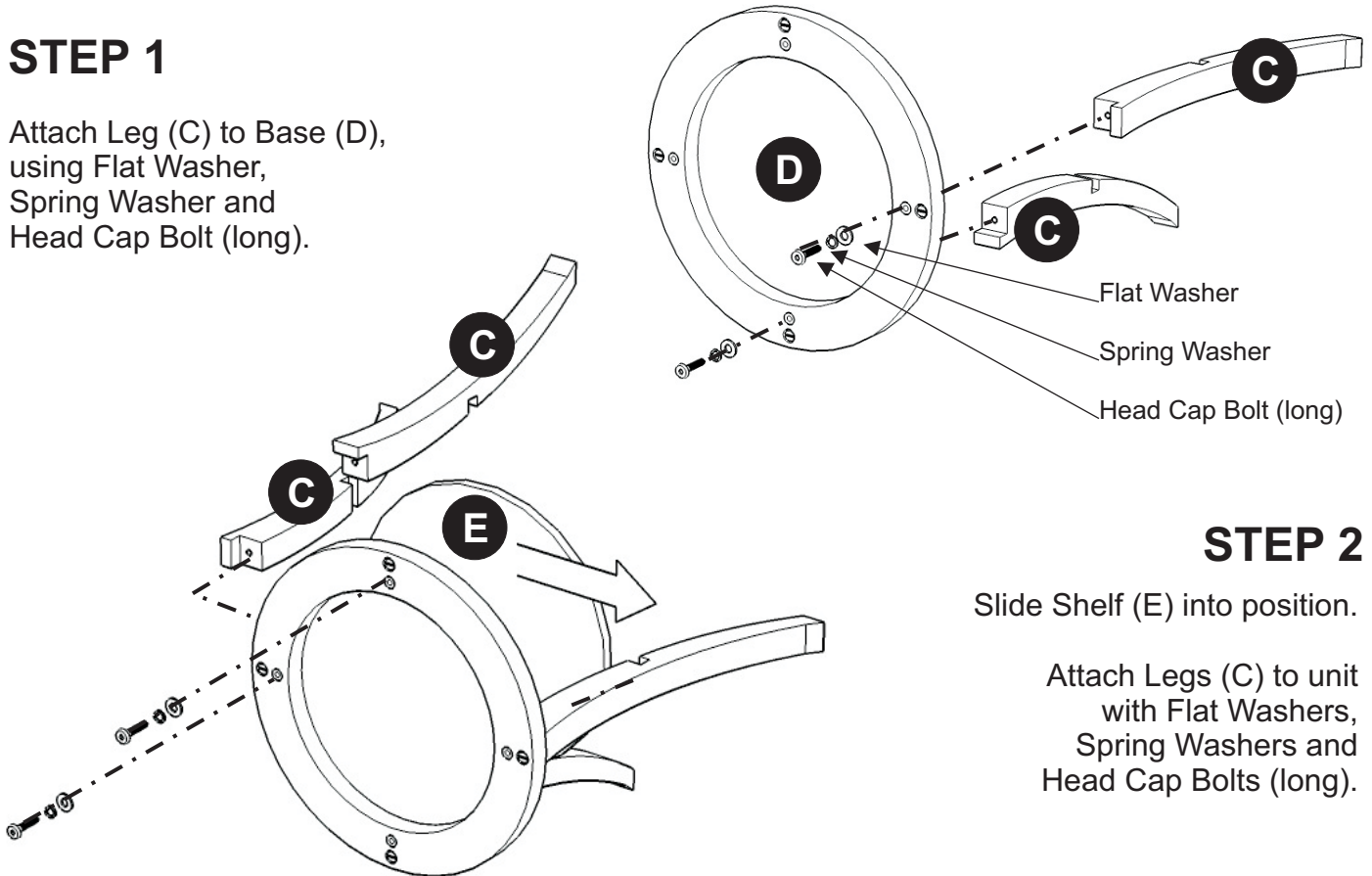

STEP 2

Slide Shelf (E) into position.

Attach Legs (C) to unit with Flat Washers, Spring Washers and Head Cap Bolts (long).

STEP 3

Attach Top Support (B) to unit, using Flat Washers, Spring Washers and Head Cap Bolts (short).

Place Spacers to the pre-drilled holes of Top Support (B).

Place Top (A) onto the unit.

Note: Top (A) is reversible and either side may be placed up. (When placing the dining table side up, align the cup holders to sit directly on the spacers.)

To level the unit, adjust the adjustable levelers on the bottom of unit. (See figure 1)

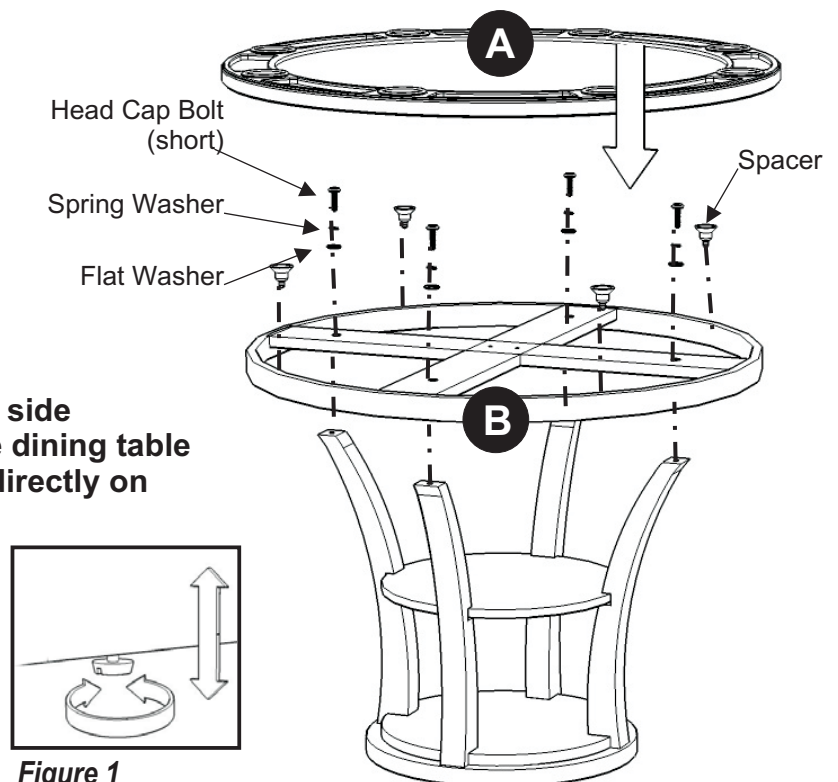

Figure 1