

# 88 5531 49 Hall Tree Stand (Ebony Finish)

## IMPORTANT NOTE

Carefully remove all the parts from the carton and put them individually on a soft cloth to prevent scratches or other damages occurring to the wood parts.

We have taken great care in the design of this product and request that you carefully and strictly follow our assembly instructions to ensure a completed product as it was designed.

*Home  
Styles*

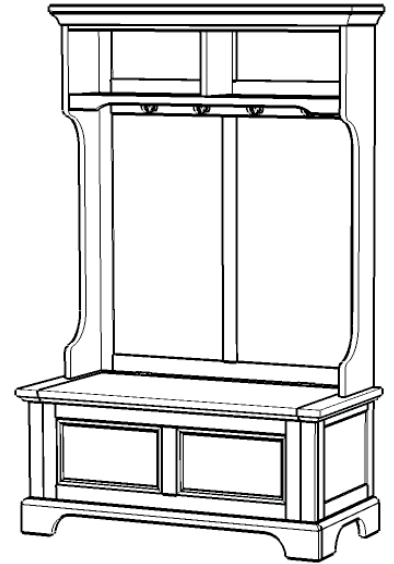

## PART LIST

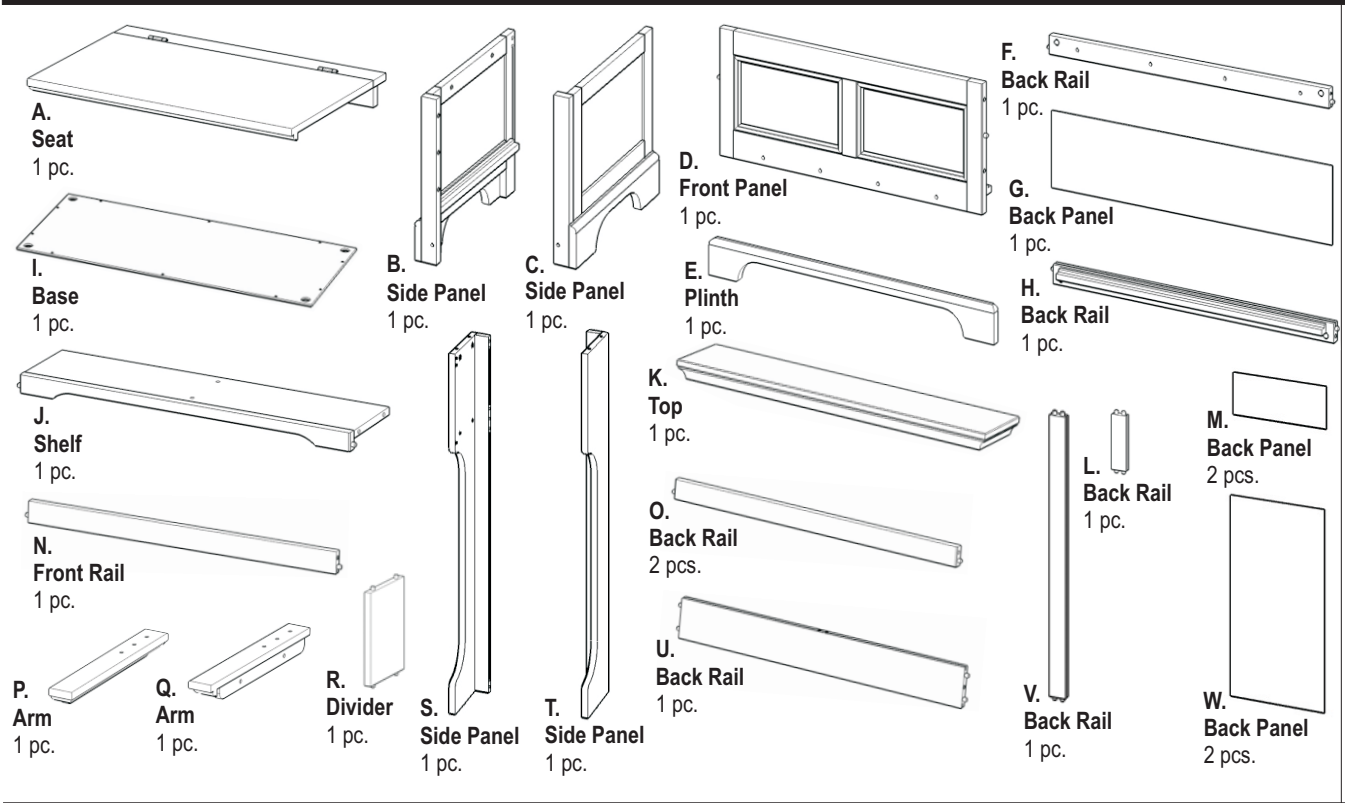

## HARDWARE LIST

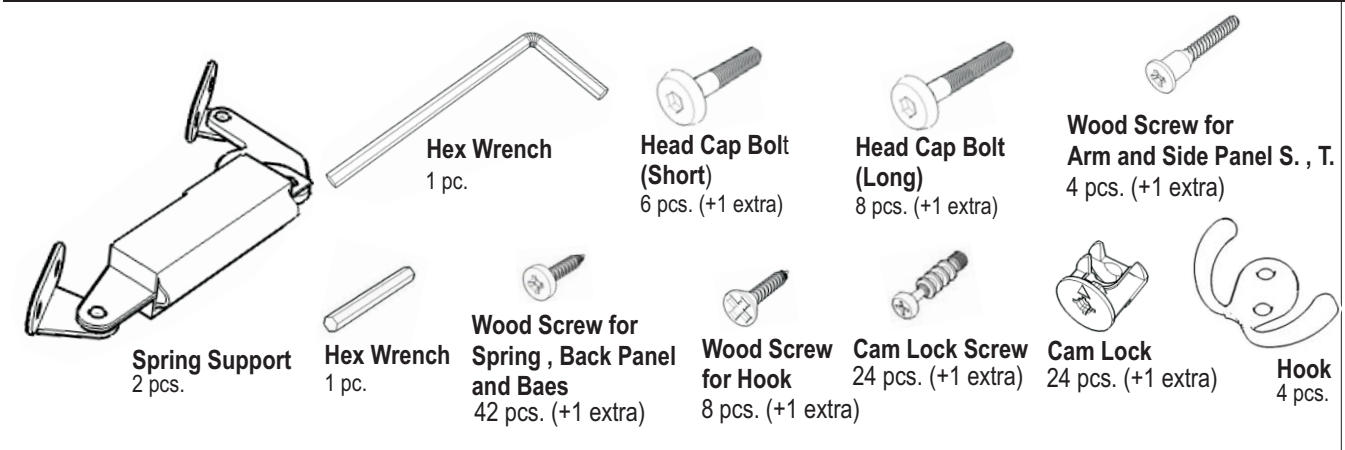

Tools Required For Assembly : **Phillips** screwdriver  
**Home Styles Consumer Assistance Line 888-680-7460 and 877-831-0319**  
**servicedesk@homestyles-furniture.com**

# Assembly Instructions 2/6

## IMPORTANT

Do not tighten up all the screws until each part is properly assembled.

You should keep Hex Wrench in a safe place as you may need to tighten the Head Cap Bolts in the future.

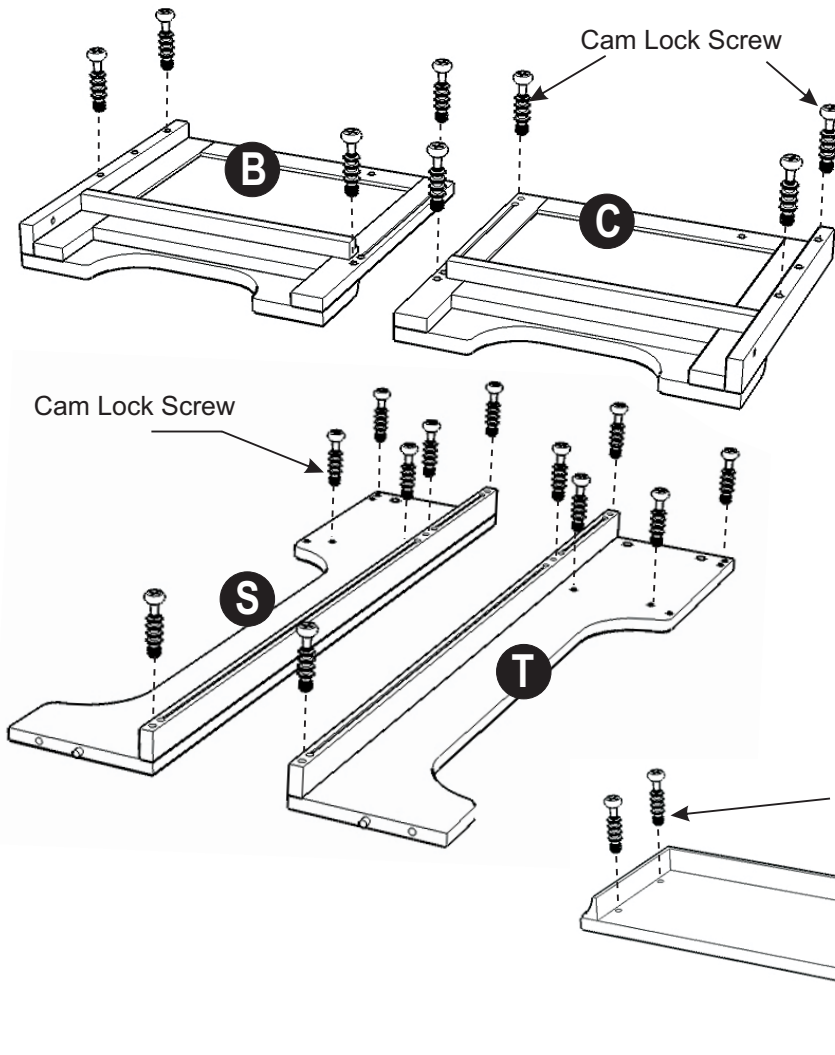

## STEP 1

Insert Cam Lock Screws into the pre-drilled holes of Side Panel (B), (C) and Side Panel (S), (T) and Top (K) then tighten.

Head Cap Bolt (Short)

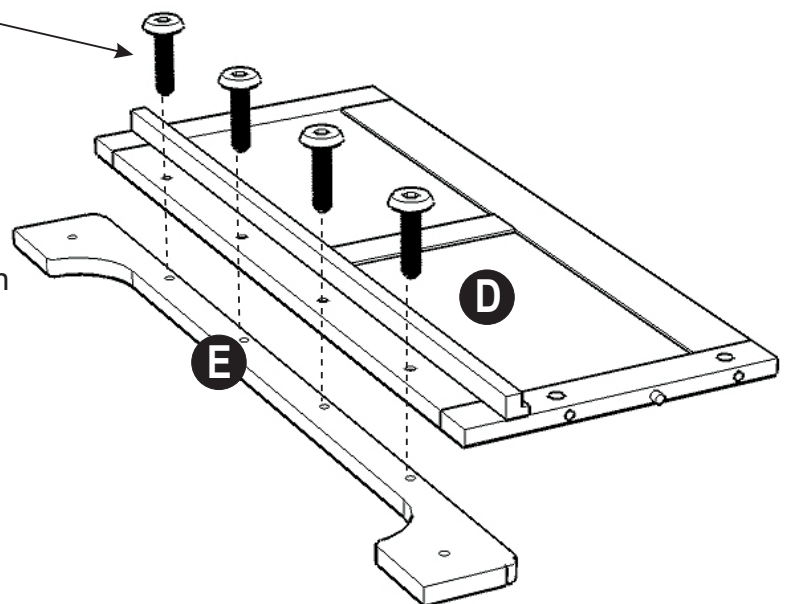

## STEP 2

Attach Front Panel (D) to Plinth (E) with Head Cap Bolts (Short).

## STEP 3

Attach Front (D) to Side Panel (B) with Cam Locks and Head Cap Bolt (Short).

Attach Back Rail (F), (H) to Side Panel (B) with Cam Locks.

Slide Back Panel (G) to the unit.

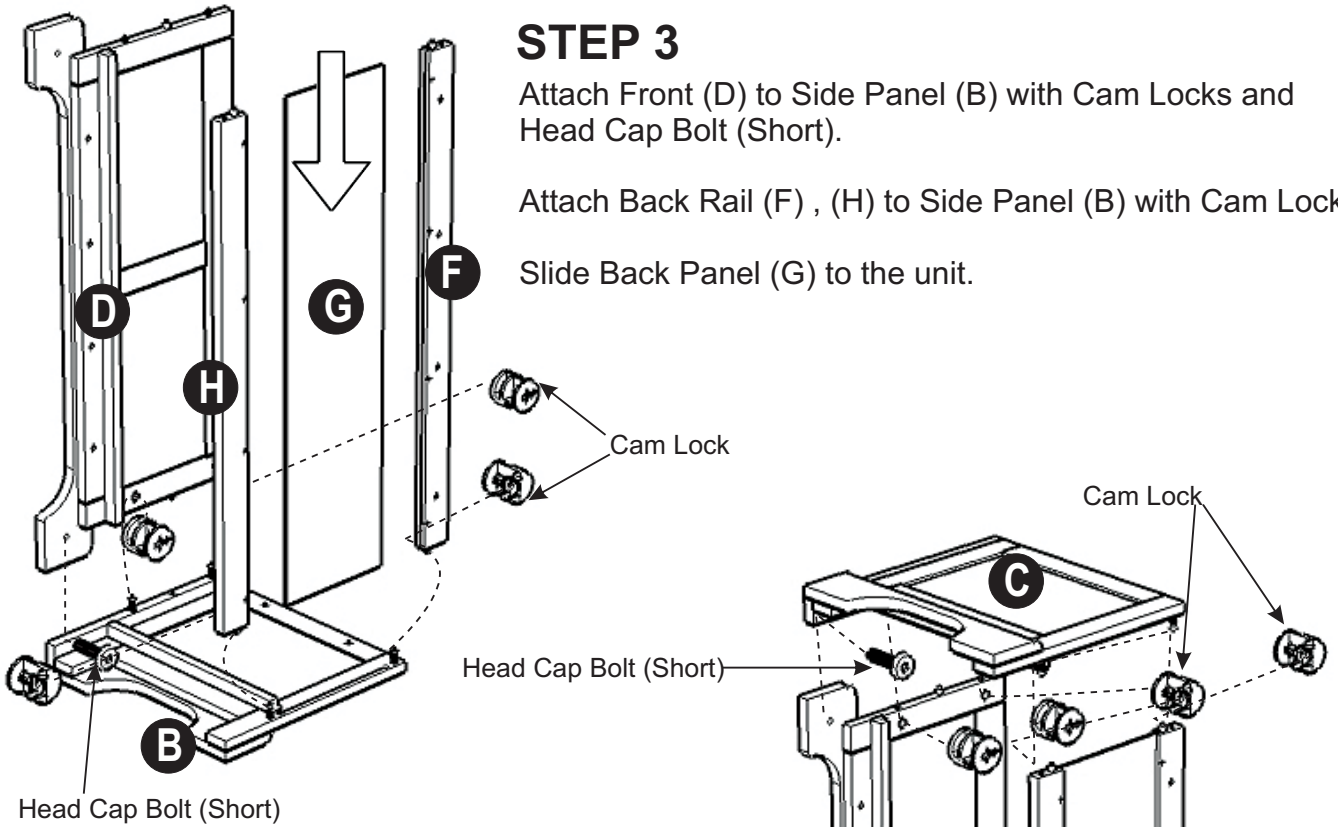

## STEP 4

Attach Side Panel (C) to the unit with Cam Locks and Head Cap Bolt (Short).

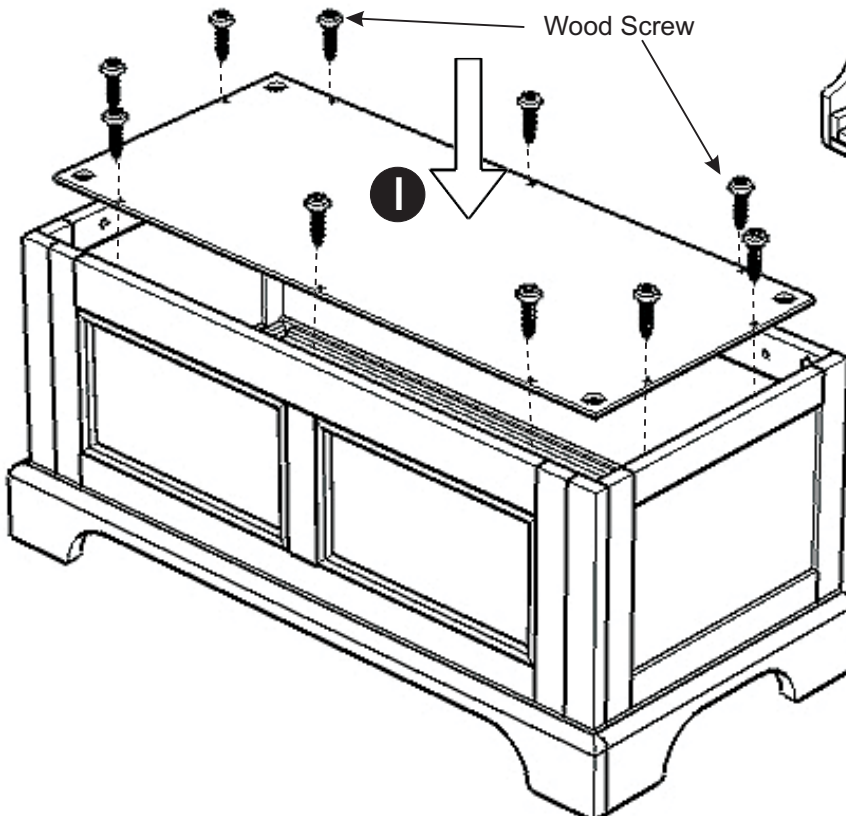

## STEP 5

Insert Base (I) to the unit with Wood Screws.

## STEP 6

Attach Back Rail (U) to Side Panel (S) with Cam Lock.

Attach Back Panel (W), (M) to Side Panel (S) and Back Rail (U).

Attach Back Rail (L) to Back Panel (M) and Back Rail (U).

Attach Back Rail (V) to Back Panel (W) and Back Rail (U).

Attach Back Panel (W), (M) and Back Rail (O) to the unit with Cam Locks.

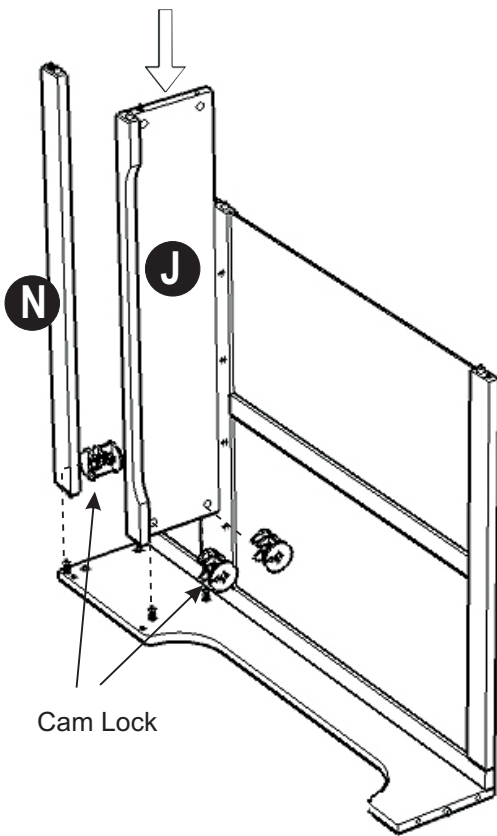
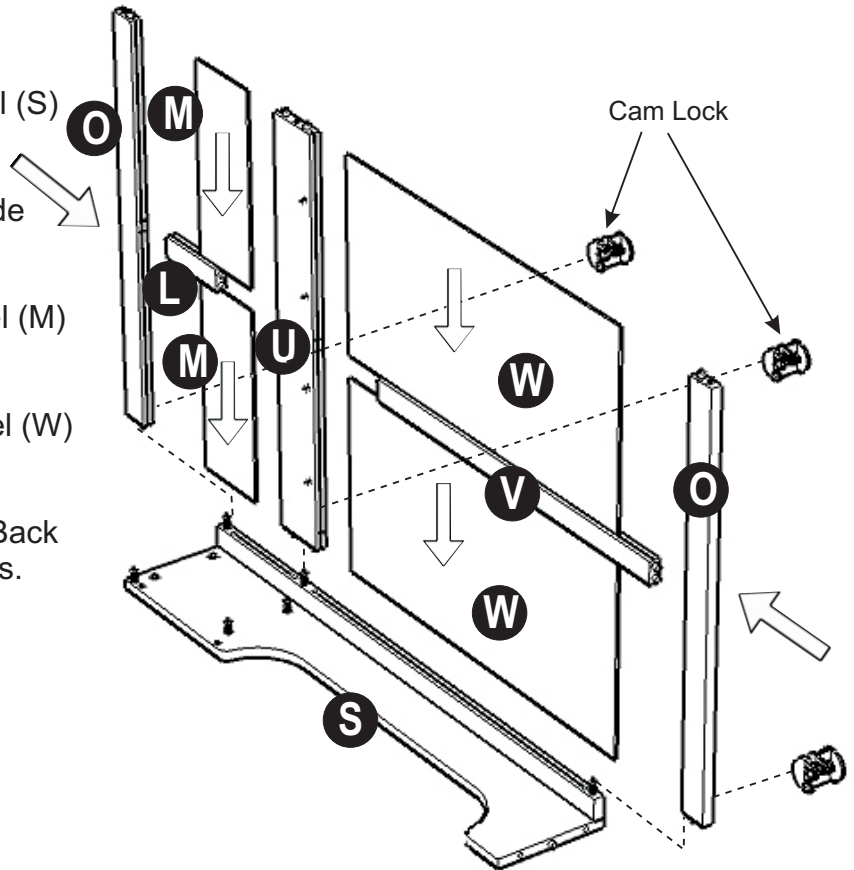

## STEP 7

Attach Front Rail (N) and Shelf (J) to the unit with Cam Locks.

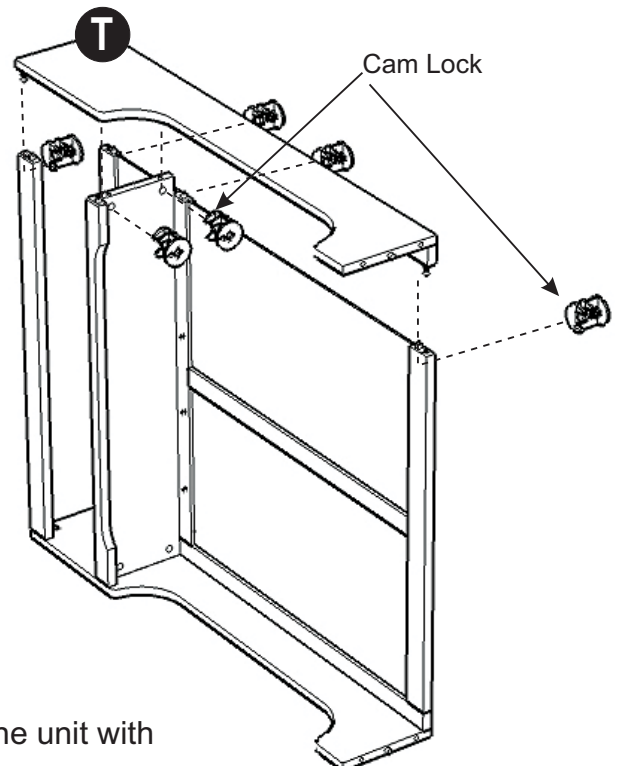

## STEP 8

Attach Side Panel (T) to the unit with Cam Locks.

## STEP 9

Attach Arm (P) , (Q) to the unit with Wood Screw for Arm.

Attach Divider (R) and Top (K) to unit with Cam Locks.

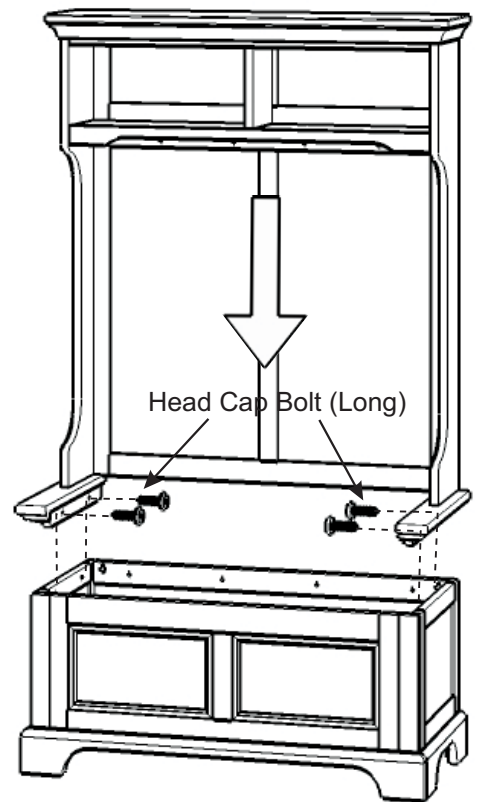
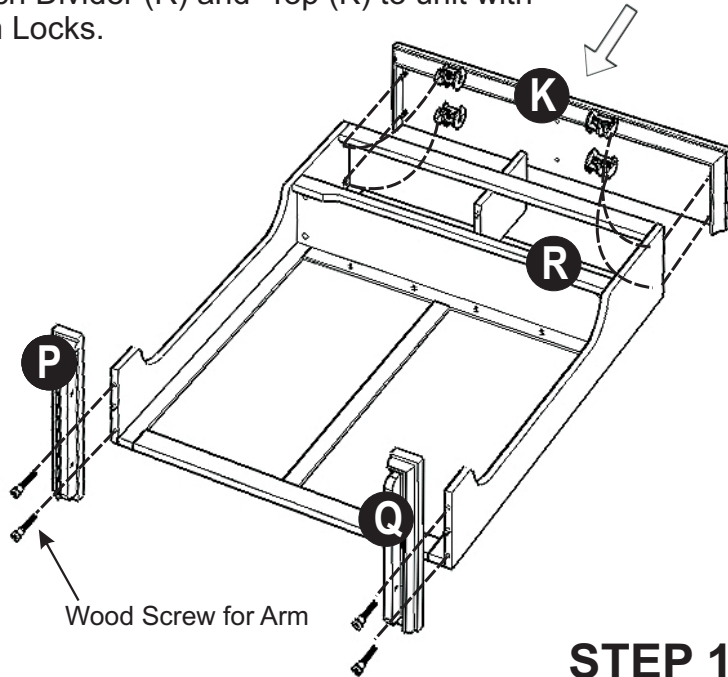

## STEP 10

Place the Top unit onto the Base Unit with Head Cap Bolts (Long).

## STEP 11

Attach the Seat (A) to the Base unit with Head Cap Bolts (Long).

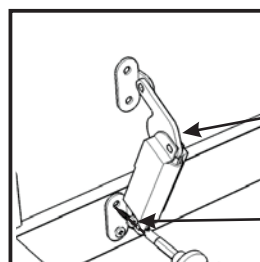
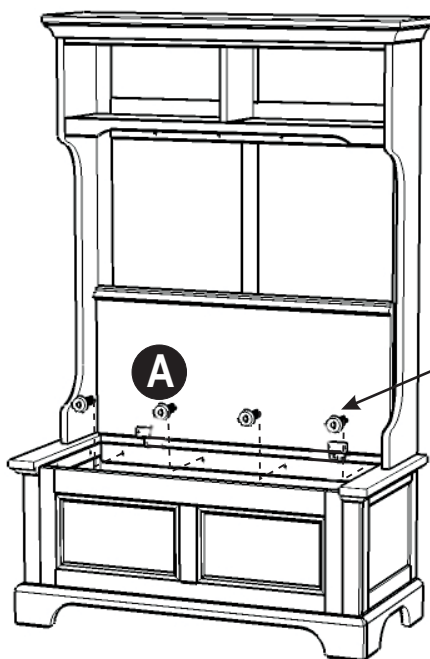

Figure 1.1

Spring Support

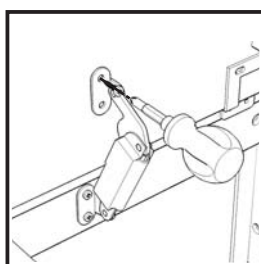
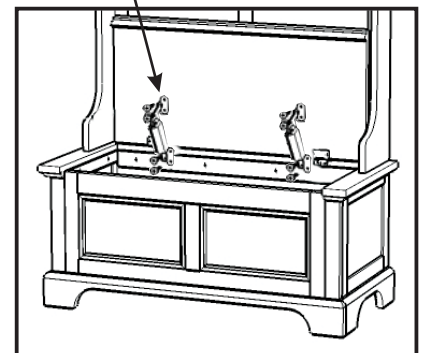

Figure 1.2

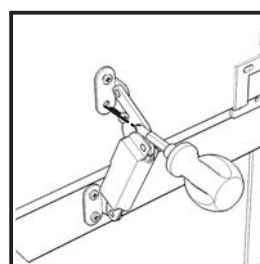
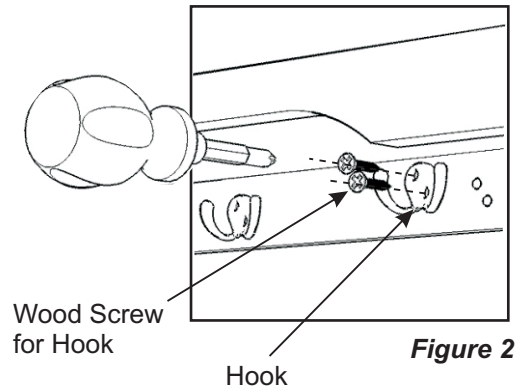
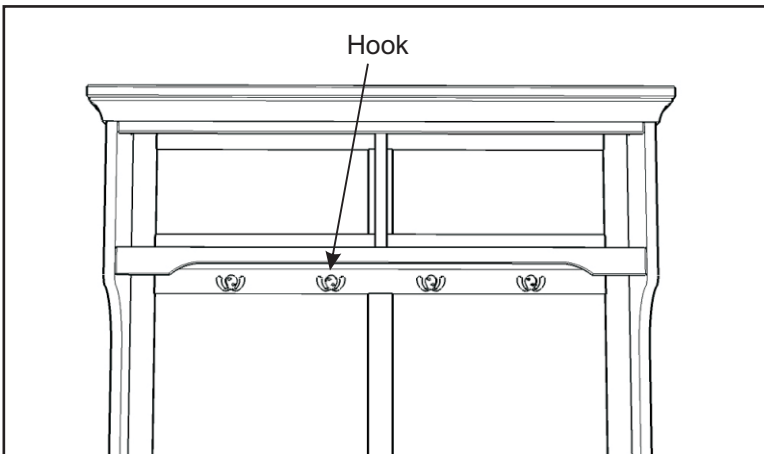

Figure 1.3

## STEP 12

Attach Spring Support to the unit with Wood Screws into the pre-drilled holes. (see Figure 1.1, 1.2, 1.3)



## STEP 13

Attach Hooks to the top of the unit with Wood Screws for Hooks.  
(see Figure 2)

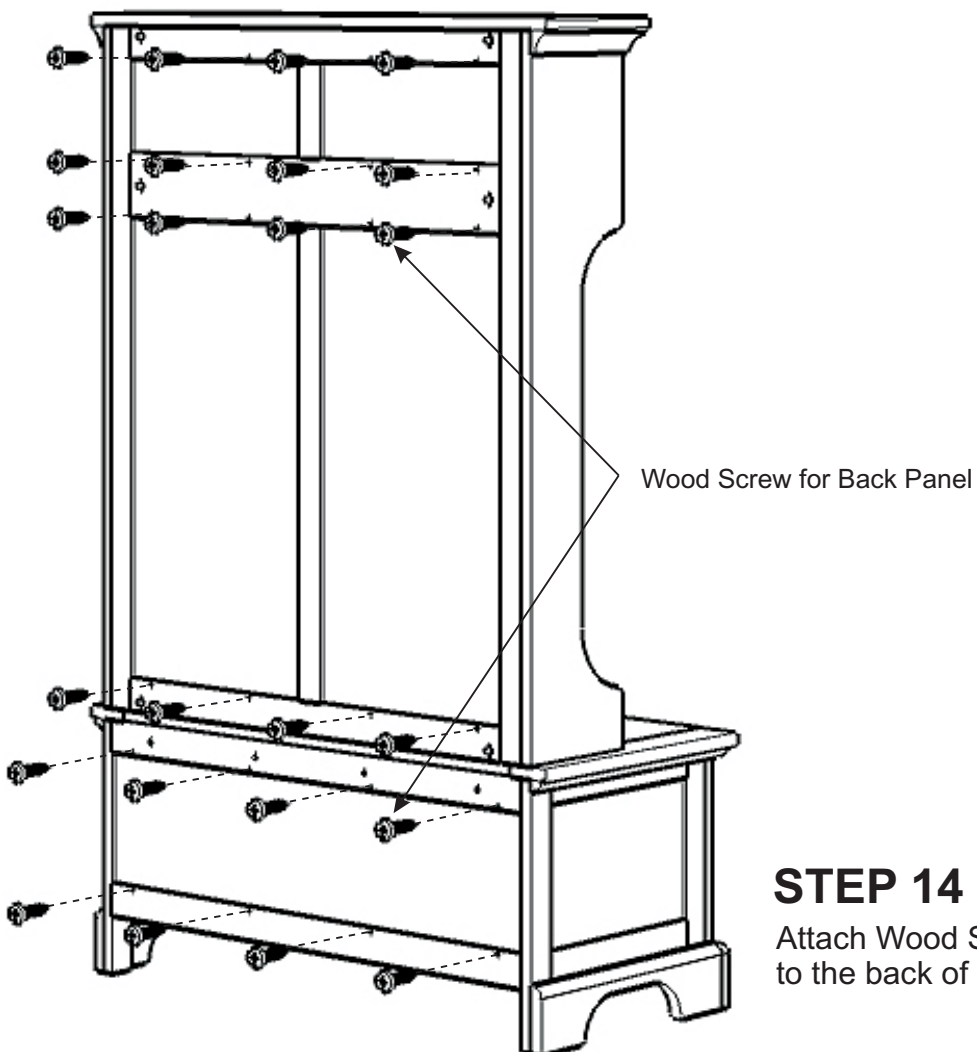

## STEP 14

Attach Wood Screws for Back Panel to the back of the unit.